

COMMERCIAL WASHERS
MODELS T-350/450/650/750/950/1450/1800
VENDED X-SERIES CONTROL



OPERATOR'S MANUAL
INSTALLATION & OPERATION
INSTRUCTIONS

Please read this information and retain for reference.

WARNING - THIS WASHER IS EQUIPPED WITH DEVICES AND FEATURES RELATING TO ITS SAFE OPERATION. TO AVOID INJURY OR ELECTRICAL SHOCK, DO NOT PERFORM ANY SERVICING UNLESS QUALIFIED TO DO SO.

IT IS THE RESPONSIBILITY OF THE OWNER TO CHECK THIS EQUIPMENT ON A FREQUENT BASIS TO ASSURE ITS SAFE OPERATION.

A machine should NOT be allowed to operate if any of the following occur:

- Excessively high water level.
- If machine is not connected to a properly grounded circuit.
- If the door does not remain securely locked during the entire cycle.
- Vibration or shaking from an inadequate mounting or foundation.

WARNING - SAFETY PRECAUTIONS

- Always shut off power and water supply before servicing.
- Do not overload the washer.
- Do not open door when cylinder is in motion or it contains water.
- Do not bypass any safety devices of this washer.
- Do not use volatile or flammable substances in or near this washer.
- Keep all panels in place. They protect against shock and injury and add rigidity to the washer.

PREVENTIVE MAINTENANCE REQUIREMENTS

DAILY

- Check that the loading door remains securely locked and cannot be opened during an entire cycle.
- Clean the top, front, and sides of the cabinet to remove residue.
- Clean the soap dispenser and lid and check that all dispenser mounting screws are in-place and tight.
- Check the loading door for leaks. Clean the door seal of all foreign matter.
- Leave the loading door open to aerate the washer when not in use.

QUARTERLY

- Make sure the washer is inoperative by switching off the main power supply.
- Check the V-belts for wear and proper tension.
- Clean lint and other foreign matter from around motor.
- Check all water connections for leaks.
- Check the drain valve for leaking and that it opens properly.
- Wipe and clean the inside of the washer and check that all electrical components are free of moisture and dust.
- Remove and clean water inlet hose filters. Replace if necessary.
- Check anchor bolts. Retighten if necessary.

IMPORTANT: Replace any and all panels that were removed to perform daily and/or quarterly maintenance.

TABLE OF CONTENTS

1	WASHER SPECIFICATION SHEET	4
2	INSTALLATION INSTRUCTIONS	5
2.1	FOUNDATION REQUIREMENTS.....	5
2.2	MOUNTING HEIGHT	5
2.3	FOUNDATION AND PAD OPTIONS	6
2.3.1	WASHER INSTALLATION ON EXISTING FLOOR:	6
2.3.2	WASHER INSTALLATION ON NEW FLOOR:.....	6
2.3.3	NEW PAD TIED TO EXISTING FLOOR:	7
2.3.4	STEEL MOUNTING BASE ON CONCRETE FLOOR:.....	8
2.4	MACHINE ANCHORING	8
2.5	MACHINE GROUTING.....	9
2.6	FLOOR LOAD DATA.....	11
2.7	MOUNTING DETAILS	12
2.7.1	T-350 Machine Mounting Detail	12
2.7.2	T-350 Machine Side By Side Mounting Detail	13
2.7.3	T-350 Commercial Washer Dimensions	14
2.7.4	T-450 Machine Mounting Detail	15
2.7.5	T-450 Side By Side Machine Mounting Detail	16
2.7.6	T-450 Commercial Washer Dimensions	17
2.7.7	T-650 Machine Mounting Detail	18
2.7.8	T-650 Machine Side By Side Mounting Detail	19
2.7.9	T-650 Commercial Washer Dimensions	20
2.7.10	T-750 Machine Mounting Detail	21
2.7.11	T-750 Machine Side By Side Mounting Detail	22
2.7.12	T-750 Commercial Washer Dimensions	23
2.7.13	T-950 Machine Mounting Detail	24
2.7.14	T-950 Machine Side By Side Mounting Detail	25
2.7.15	T-950 Commercial Washer Dimensions	26
2.7.16	T-1450 Machine Mounting Detail	27
2.7.17	T-1450 Machine Side By Side Mounting Detail	28
2.7.18	T-1450 Commercial Washer Dimensions	29
2.7.19	T-1800 Machine Mounting Detail	30
2.7.20	T-1800 Machine Side By Side Mounting Detail	31
2.7.21	T-1800 Commercial Washer Dimensions	32
2.8	PLUMBING	33

2.9	DRAIN	33
2.10	PROTECTIVE FILM.....	33
2.11	ELECTRICAL.....	33
2.11.1	INSTALLING THE ELECTRICAL CONNECTION	35
2.11.2	FUSING REQUIREMENTS	35
2.11.3	CONTROLS TRANSFORMER (208-240V 60 Hz models only)	35
2.11.4	CONTROLS TRANSFORMER (230V 50 Hz models only).....	36
2.11.5	VARIABLE FREQUENCY DRIVE ADJUSTMENTS (208-240V 60 Hz T-950 model only)	37
2.12	OPERATION CHECK	37
3	OPERATING INSTRUCTIONS.....	38
3.1	STARTING THE WASHER.....	38
3.2	END OF CYCLE	39
3.3	EMERGENCY STOP / SAFETY DOOR LOCK.....	39
3.4	VARIABLE FREQUENCY DRIVE INDICATORS	40
4	MACHINE PROGRAMMING INSTRUCTIONS	41
4.1	MANUAL PROGRAMMING	41
4.2	SYSTEM INFO.....	42
4.3	GENERAL	43
4.4	PROFILES.....	45
4.5	OPTIONAL CYCLES	50
4.6	USAGE	50
4.7	ERROR LOGS.....	52
4.8	FACTORY RESET.....	52
4.9	COIN WASHER DEFAULT CYCLE	53
4.10	WASHERS WITHOUT COIN ACCEPTORS.....	54
4.11	WATER LEVEL ADJUSTMENT	54
5	DISPLAYED WASHER MESSAGES.....	55
6	TROUBLESHOOTING	62
7	TRANSIENT VOLTAGE SURGE SUPPRESSORS	66
8	SERVICE AND PARTS.....	67

1 WASHER SPECIFICATION SHEET

		T-350		T-450		T-650		T-750		T-950		T-1450		T-1800		
Capacity	Dry Weight Capacity - lb (kg)	20	(9.1)	30	(13.6)	40	(18.1)	50	(22.7)	60	(27.2)	90	(40.8)	120	(54.4)	
	Cylinder Volume - cu ft (L)	2.7	(76.5)	3.8	(107.6)	6	(170)	6.5	(184.1)	9	(254.9)	13.7	(388)	17.4	(492.7)	
Speed	High Extract Speed - g (RPM)	200	(819)	200	(750)	200	(750)	200	(685)	200	(685)	200	(617)	100	(436)	
	Intermediate Extract Speed - g (RPM)	60	(449)	60	(411)	60	(411)	60	(375)	60	(375)	60	(338)	60	(338)	
	Washing Speed - g (RPM)	0.9	(55)	0.9	(50)	0.9	(50)	0.9	(43)	0.9	(43)	0.9	(39)	0.9	(39)	
	Motor Size - hp (kW)	1	(0.75)	2	(1.5)	2	(1.5)	3	(2.2)	3	(2.2)	6.7	(5)	7.8	(5.8)	
Dimensions	Cabinet Height - in (cm)	43 7/8	(111.4)	48 3/16	(122.4)	53	(134.6)	55 3/8	(140.7)	55 3/8	(140.7)	62 3/8	(158.4)	62 3/8	(158.4)	
	Cabinet Width - in (cm)	26	(66)	29 7/8	(75.9)	29 7/8	(75.9)	34 3/8	(87.3)	34 3/8	(87.3)	41 1/2	(105.4)	41 1/2	(105.4)	
	Cabinet Depth - in (cm)	28	(71.1)	28 1/4	(71.8)	38 1/8	(96.8)	32 7/8	(83.5)	38 7/8	(98.7)	42 1/4	(107.3)	48 1/4	(122.6)	
	Door Opening - in (cm)	12 1/4	(31.1)	15 1/4	(38.7)	15 1/4	(38.7)	19 1/4	(48.9)	19 1/4	(48.9)	19 1/4	(48.9)	19 1/4	(48.9)	
	Floor to Door Bottom - in (cm)	14 7/8	(37.8)	16 1/4	(41.3)	16 1/4	(41.3)	16	(40.6)	16	(40.6)	19 5/16	(49.1)	19 5/16	(49.1)	
	Cylinder Diameter - in (cm)	21	(53.3)	25	(63.5)	25	(63.5)	30	(76.2)	30	(76.2)	37	(94)	37	(94)	
	Cylinder Depth - in (cm)	13 1/2	(34.3)	13 3/8	(34)	21 1/8	(53.7)	16	(40.6)	22	(55.9)	22	(55.9)	28	(71.1)	
	Weight	Net Weight - lb (kg)	383	(173.7)	526	(238.6)	744	(337.5)	925	(419.6)	1000	(453.6)	1322	(599.6)	1415	(641.8)
Shipping	Shipping Weight - lb (kg)	407	(184.6)	544	(246.8)	766	(347.5)	952	(431.8)	1016	(460.8)	1364	(618.7)	1460	(662.2)	
	Shipping Height - in (cm)	49 1/4	(125.1)	53 1/4	(135.3)	58 3/4	(149.2)	61 1/2	(156.2)	61 1/2	(156.2)	69 1/4	(175.9)	69 1/4	(175.9)	
	Shipping Width - in (cm)	28 1/4	(71.8)	31 1/2	(80)	31 1/2	(80)	36	(91.4)	36	(91.4)	43 1/8	(109.5)	43 1/8	(109.5)	
	Shipping Depth - in (cm)	33 1/2	(85.1)	33 1/2	(85.1)	43 3/4	(111.1)	38	(96.5)	45 1/4	(114.9)	48	(121.9)	54	(137.2)	
Water	Water Inlet Size - in (mm)	3/4	(19)	3/4	(19)	3/4	(19)	3/4	(19)	3/4	(19)	3/4	(19)	3/4	(19)	
	Pressure (min-max) - psi (kPa)	30-120	(207-827)	30-120	(207-827)	30-120	(207-827)	30-120	(207-827)	30-120	(207-827)	30-120	(207-827)	30-120	(207-827)	
	Flow Rate - gal/min (L/min)	9	(34)	9	(34)	9	(34)	9	(34)	9 & 12	(34 & 45)	9 & 12	(34 & 45)	9 & 12	(34 & 45)	
	Approx. Water Usage Per - gal (L)	15.8	(59.8)	22.2	(84)	35.1	(132.9)	38.4	(145.4)	52.6	(199.1)	80.1	(303.2)	95.6	(361.9)	
	Drain Diameter (O.D.) - in (cm)	2 1/4	(5.7)	3	(7.6)	3	(7.6)	3	(7.6)	3	(7.6)	3	(7.6)	3	(7.6)	
	Floor to Center of Drain - in (cm)	6	(15.2)	5	(12.7)	6 7/8	(17.5)	6 5/8	(16.8)	6 5/8	(16.8)	8 5/16	(21.1)	8 5/16	(21.1)	
Electrical	Model	Volts / Hz / Phase / Wiring														
	-12	Circuit Breaker Amps / Running Amps / Wire Size														
		208-240 / 60 / 1 / 2 wire + ground	15 / 6.2 / #12		15 / 6.2 / #12		15 / 6.2 / #12		20 / 8.4 / #12		20 / 12 / #12		30 / 15 / #10		30 / 16.6 / #10	
-39	230 / 50 / 1 / 2 wire + ground		15 / 6.2 / 3.5 mm ²		15 / 6.2 / 3.5 mm ²		15 / 6.2 / 3.5 mm ²		20 / 8.4 / 3.5 mm ²		20 / 12 / 3.5 mm ²		30 / 15 / 5.3 mm ²		30 / 16.6 / 5.3 mm ²	
Installation	Min. Clearance Between Machines - in (cm)	1/2	(1.3)	1/2	(1.3)	1/2	(1.3)	1/2	(1.3)	1/2	(1.3)	1/2	(1.3)	1/2	(1.3)	
	Min. Clearance Behind Machines - in (cm)	24	(61)	24	(61)	24	(61)	24	(61)	24	(61)	24	(61)	24	(61)	
	Min. Concrete Thickness - in (cm)	6	(15.2)	6	(15.2)	8	(20.3)	8	(20.3)	8	(20.3)	12	(30.5)	12	(30.5)	

NOTE:

For some models, Final Extract Speed is dependent on load and incoming voltage. Refer to the Electrical Installation section for more details.

2 INSTALLATION INSTRUCTIONS

All washers must be installed in accordance with all local, state and national building, electrical, plumbing and other codes in effect in the area.

WARNING:
THESE INSTALLATION AND SERVICING INSTRUCTIONS ARE FOR USE BY QUALIFIED PERSONNEL ONLY. TO AVOID INJURY AND ELECTRICAL SHOCK, DO NOT PERFORM ANY SERVICING OTHER THAN THAT CONTAINED IN THE OPERATING INSTRUCTIONS, UNLESS QUALIFIED.

2.1 FOUNDATION REQUIREMENTS

T-350, 450, 650, 750, 950, 1450, 1800:

This machine is designed for use on or over bare concrete floor - not to be used above combustible flooring, such as carpet or wood. The washer must be securely bolted **and grouted** to a substantial concrete floor or mounted **and grouted** upon a suitable base that is securely bolted **and grouted** to a substantial concrete floor. See Machine Grouting section for details.

CARE MUST BE TAKEN WITH ALL FOUNDATION WORK TO ENSURE A STABLE UNIT INSTALLATION, ELIMINATING POSSIBILITIES OF EXCESSIVE VIBRATION.

Allow a minimum 24 inches (610 mm) of clearance behind the rear of the machine to provide access for motor service.

Installation on an isolated pad is NOT recommended. Consult a structural engineer for installations that will not be tied to a surrounding floor.

2.2 MOUNTING HEIGHT

A concrete pedestal or steel-mounting base that elevates the machine above the floor level is suggested to provide easy access to the loading door.

Suggested Amount to Elevate Washer:

T-350: approximately 8 inches (203 mm)

T-450: approximately 6 inches (152 mm)

T-650/750/950/1450/1800: approximately 4 inches (102 mm)

Contact a Dexter laundry equipment distributor for recommended steel mounting bases. Available steel mounting bases:

Washer	Part Number	Height
T-350	9945-121-001	8" (203 mm) Single Base
T-450	9945-123-001	6" (152 mm) Single Base
T-650	9945-145-001	6" (152 mm) Single Base
T-750	9945-117-001	6" (152 mm) Single Base

T-950	9945-103-001	4" (103 mm) Single Base
T-950	9945-118-001	6" (152 mm) Single Base
T-1450	9945-137-001	4" (103 mm) Single Base
T-1800	9945-159-001	4" (103 mm) Single Base

If an elevated concrete pedestal is desired, it should be embedded and tied into the existing floor. DO NOT install a pad on top of the existing floor. Cut through existing floor as shown below. See Machine Mounting Detail Figures for floor thickness and bolt sizes.

EXPANSION ANCHORS ARE NOT RECOMMENDED FOR USE IN CONCRETE PEDESTALS BECAUSE THE ANCHORS ARE TOO CLOSE TO AN EDGE, CAUSING IT TO BREAK OUT.

2.3 FOUNDATION AND PAD OPTIONS

All installations require reinforced concrete floors. Refer to appropriate model Machine Mounting Detail Figures 1-1, 1-2 and 1-3 for minimum floor thickness and minimum pad sizes. See mounting diagram for overall washer dimensions.

Refer to appropriate model Figure 1-4 for side by side mounting dimensions.

2.3.1 WASHER INSTALLATION ON EXISTING FLOOR:

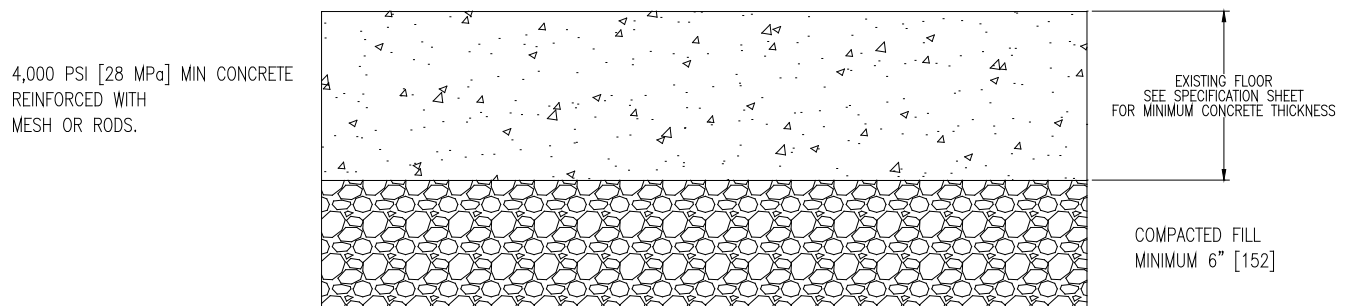

2.3.2 WASHER INSTALLATION ON NEW FLOOR:

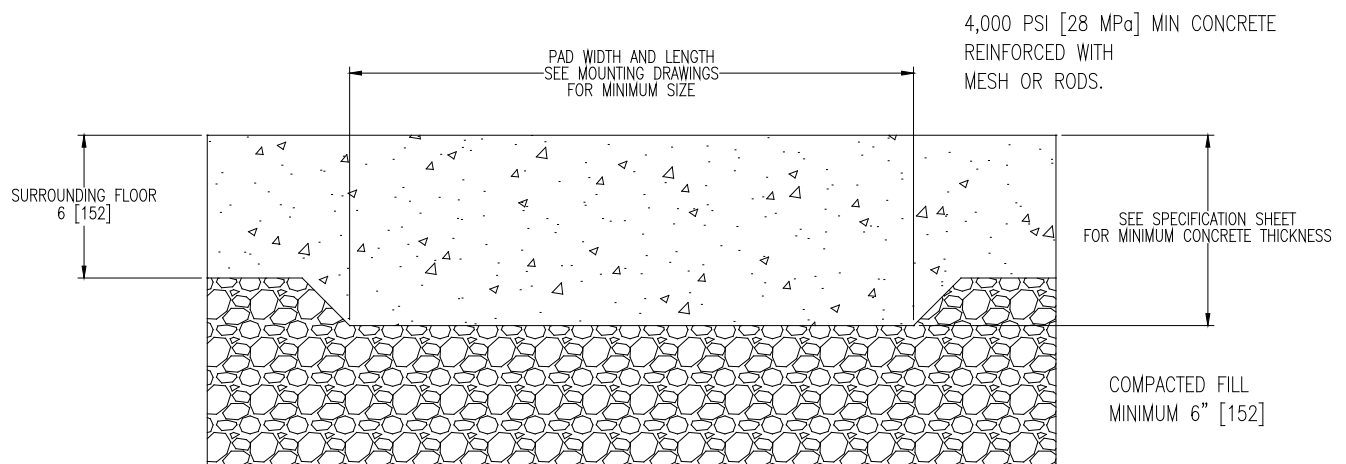

2.3.3 NEW PAD TIED TO EXISTING FLOOR:

If the existing floor is not reinforced concrete that meets the minimum thickness requirements, DO NOT install a pad on top of the existing floor. The existing floor and the machine pad must be tied together as one piece as follows:

- 1) Cut an opening through the existing floor that is wider and deeper than the washer as shown below. See Machine Mounting Details for dimensions.
- 2) Excavate to a depth that allows for 6" [152] minimum of compacted fill plus the minimum required concrete thickness. Also excavate 2" [51] under the existing floor so that the new concrete is poured under the floor as well.
- 3) Back fill with clean fill dirt and compact dirt, making sure to allow for the minimum thickness concrete pad to be poured.
- 4) Drill holes around the perimeter of the existing floor to install reinforcing bars to tie the new pad to the existing floor. Drill 2-1/2" [64] deep into the existing floor on 12" [305] centers around the entire perimeter.
- 5) Clean holes and fill half-way with acrylic adhesive rated for commercial-grade machine installations.
- 6) Use #4 (60 ksi) reinforcing bar to tie the new pad to the existing floor. Tie the bars together at intersections and use supports to hold bars in the proper depth in the pad.
- 7) After adhesive has cured, pour 4000 psi concrete up to level with the existing floor plus any extra elevated pedestal desired 4-10" [102-254]. Concrete must be done in one pour so that the entire pad cures as one piece.

2.3.3.1 NEW PAD TIED TO EXISTING FLOOR (LEVEL WITH FLOOR):

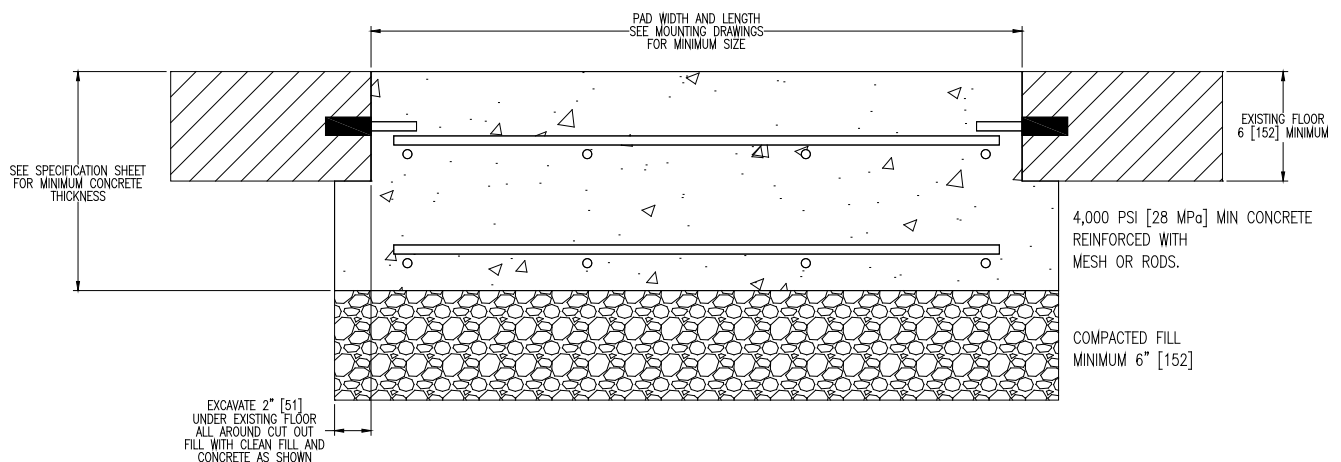

2.3.3.2 NEW RAISED CONCRETE PEDESTAL TIED TO EXISTING FLOOR:

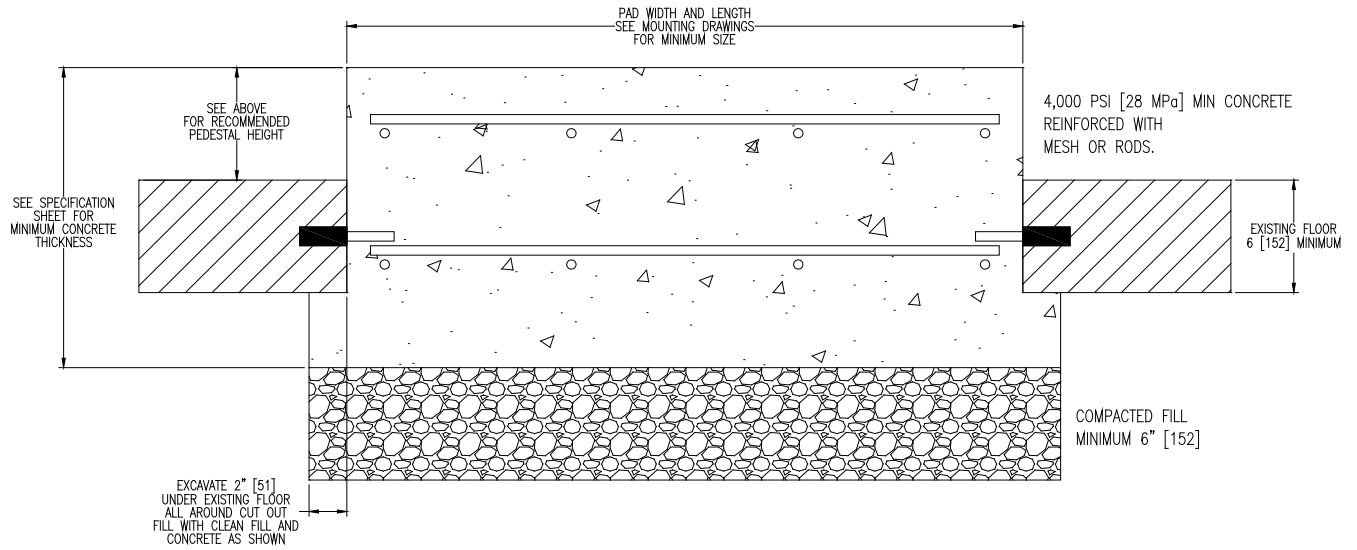

2.3.4 STEEL MOUNTING BASE ON CONCRETE FLOOR:

SIDE VIEW

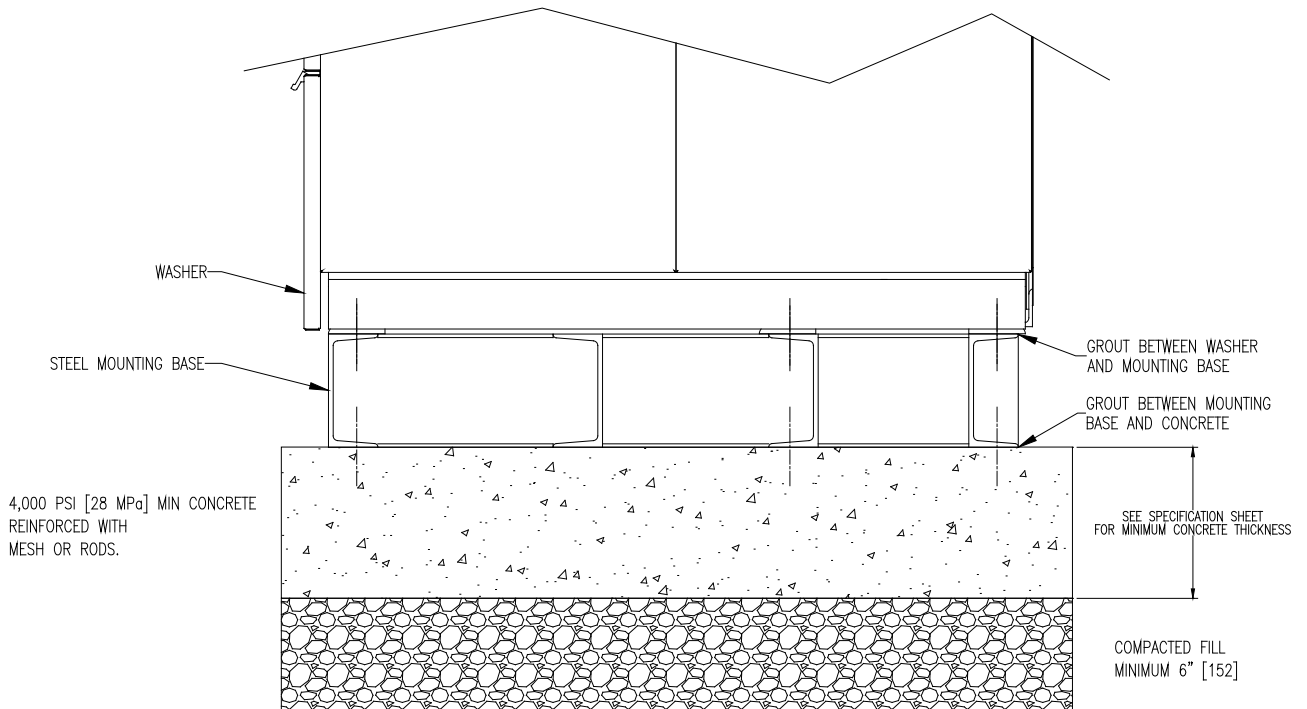

2.4 MACHINE ANCHORING

All installations require concrete floors and quality grade anchor bolts or expansion anchors. Mounting hardware is not provided with the machines. Refer to appropriate model Machine Mounting Detail Figures 1-1, 1-2 and 1-3 for floor thickness and bolt sizes. See mounting diagram for overall washer dimensions.

EXPANSION ANCHORS ARE NOT RECOMMENDED FOR USE IN RAISED

CONCRETE PEDESTALS BECAUSE THE ANCHORS ARE TOO CLOSE TO AN EDGE, CAUSING IT TO BREAK OUT.

ANCHORING OPTIONS:

2.4.1 *Cast in place bolts headed by square fish plates. See Machine Mounting Detail Figures 1-1 thru 1-3 for exact washer model.*

Or after concrete has completely cured:

2.4.2 *Use Hilti Adhesive System 'HAS' Rods and adhesive capsules. See Machine Mounting Detail Figures 1-1 thru 1-3 for exact washer model.*

2.4.3 *Or use an equivalently rated epoxy or acrylic adhesive anchor.*

As an installation aid, the anchor pattern can be found on the back panel of the washers and can be used as a template. Compare panel to the mounting dimension drawing to find the right holes.

Example:

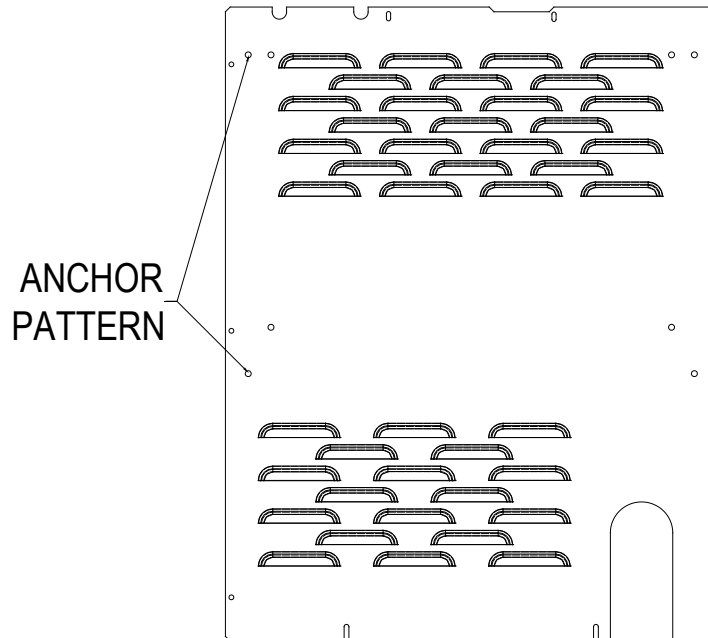

2.5 MACHINE GROUTING

After concrete has cured completely and anchors have cured completely into place:

2.5.1 *Position washer over the mounting anchors.*

2.5.2 *Raise the washer 1/2" [12.7] off the mounting surface and place spacers under the corners of the washer base.*

2.5.3 *Level the washer, leaving washer at least 1/2" [12.7] off the mounting surface.*

Do not permanently support the washer with spacers under the corners. Machine must be grouted, and spacers must be removed.

2.5.4 *Mix non-shrinking machinery grout according to the grout instructions.*

*The grout should not be too runny or too firm. **Completely fill** the 1/2" [12.7] space between the washer base and the mounting surface. Force grout under all base angles and plates until completely filled. Fill around all anchor bolts.*

2.5.5 Finger tighten all nuts to anchor bolts.

2.5.6 When the grout has started to stiffen (but before it is cured), remove the spacers from the corners and allow the washer to settle into the wet grout. Fill in any voids as necessary with additional grout.

2.5.7 Allow grout to completely cure, then tighten all nuts to securely fasten the washer to the grouted mounting surface.

2.5.8 Retighten nuts after 5 days of operation and check quarterly.

If using a steel mounting base, first grout the steel mounting base to the concrete floor using the above steps, then repeat the steps for mounting and grouting the washer to the steel mounting base.

2.6 FLOOR LOAD DATA

DEXTER DYNAMIC LOADING CHART										
Model	Dry Weight Capacity (lb [kg])	Extract Speed (RPM)	Extract G-Force	Maximum Static Load (lb [kN])	Static Load Pressure (lb/sq ft [kN/ sq m])	Total Dynamic Load (lb [kN])	Dynamic Load Pressure (lb/sq ft [kN/ sq m])	Dynamic Load Frequency (Hz)	Maximum Vertical Load (lb [kN])	Maximum Moment About Washer Base (ft*lbs [m-kN])
T-350	20 [9.1]	819	200	447 [2.0]	94 [4.5]	800 [3.6]	168 [8.0]	13.7	1203 [5.4]	1571 [2.1]
T-450	30 [13.6]	750	200	618 [2.7]	113 [5.4]	1200 [5.3]	220 [10.5]	12.5	1756 [7.8]	2631 [3.6]
T-650	40 [18.1]	750	200	882 [3.9]	134 [6.4]	1600 [7.1]	243 [11.6]	12.5	2384 [10.6]	3508 [4.8]
T-750	50 [22.7]	685	200	1119 [5.0]	166 [7.9]	2000 [8.9]	297 [14.2]	11.4	2970 [13.2]	4667 [6.3]
T-950	60 [27.2]	685	200	1206 [5.4]	150 [7.2]	2400 [10.7]	299 [14.3]	11.4	3460 [15.4]	5600 [7.6]
T-1450	90 [40.8]	617	200	1635 [7.3]	163 [7.8]	3600 [16.0]	360 [17.2]	10.3	5012 [22.3]	9413 [12.8]
T-1800	120 [54.4]	436	100	1818 [8.1]	158 [7.6]	2400 [10.7]	208 [10]	7.3	3935 [17.5]	6275 [8.5]

Note: The out-of-balance loading conditions may vary depending on load size, model and material.

2.7 MOUNTING DETAILS

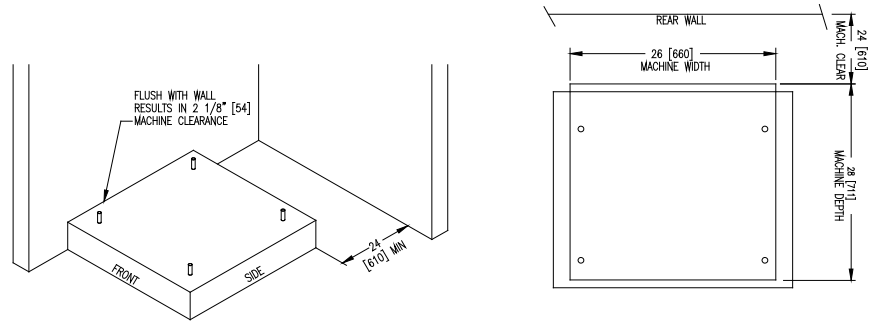

FLOOR OUTLINE
Figure 1-2

5/8" X 8" GD. 8 BOLTS
HEADED BY 4" SQ. FISH PLATE OR EQUIV.
(1 7/8" BOLT PROTRUSION)

OR

HILTI[®] ADHESIVE ANCHORING SYSTEM.
HILTI[®] HAS[®] SUPER RODS 5/8" X 8" AND ADHESIVE CAPSULES
FOR MORE INFORMATION CALL
HILTI CUSTOMER SERVICE
1-800-879-8000

OR

EQUIVALENT EPOXY OR
ACRYLIC ADHESIVE ANCHOR

[ANCHORS: 16mm X 200mm GRADE 8 BOLTS
HEADED BY 100 SQ. FISH PLATE OR EQUIV.
(48mm BOLT PROTRUSION)]

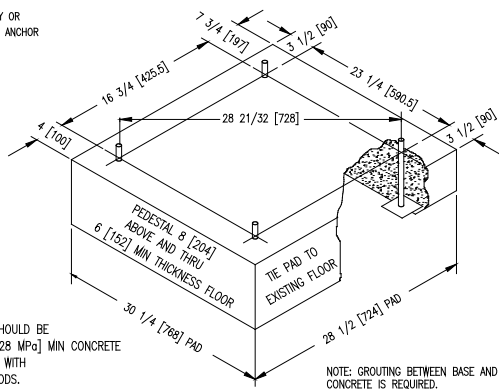

PEDESTAL SHOULD BE
4,000 PSI [28 MPa] MIN CONCRETE
REINFORCED WITH
MESH OR RODS.

NOTE: GROUTING BETWEEN BASE AND
CONCRETE IS REQUIRED.

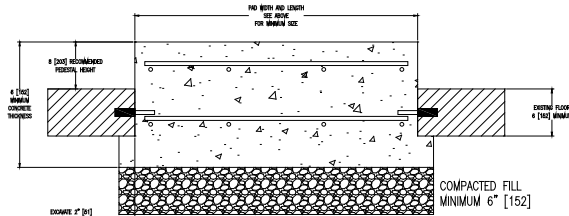

CONCRETE PEDESTAL TIED TO EXISTING FLOOR

RAISED CONCRETE PEDESTAL MOUNTING OPTION

Figure 1-1

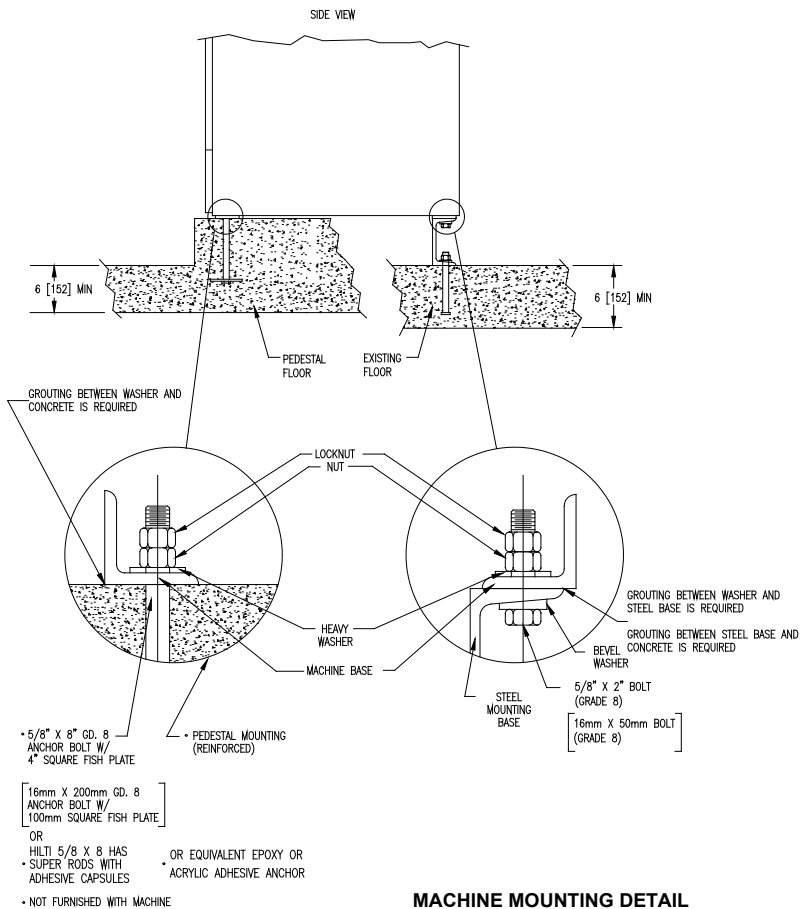

• 5/8" X 8" GD. 8
ANCHOR BOLT W/
4" SQUARE FISH PLATE

[16mm X 200mm GD. 8
ANCHOR BOLT W/
100mm SQUARE FISH PLATE]

OR
HILTI 5/8" X 8" HAS
SUPER RODS WITH
ADHESIVE CAPSULES

• NOT FURNISHED WITH MACHINE

OR EQUIVALENT EPOXY OR
ACRYLIC ADHESIVE ANCHOR

MACHINE MOUNTING DETAIL

Figure 1-3

2.7.1 T-350 Machine Mounting Detail

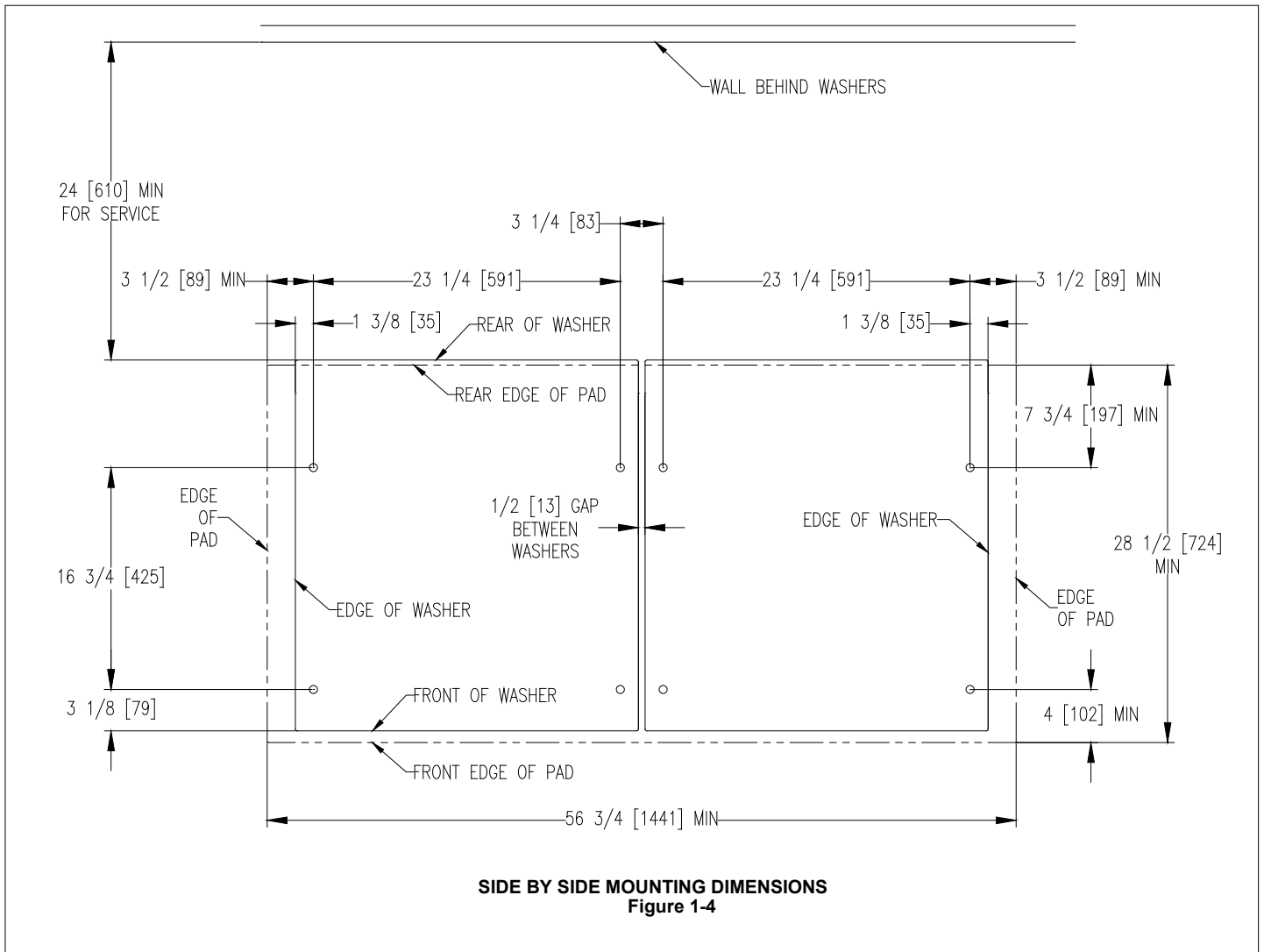

2.7.2 T-350 Machine Side By Side Mounting Detail

T-350 COMMERCIAL WASHER MOUNTING DIMENSIONS

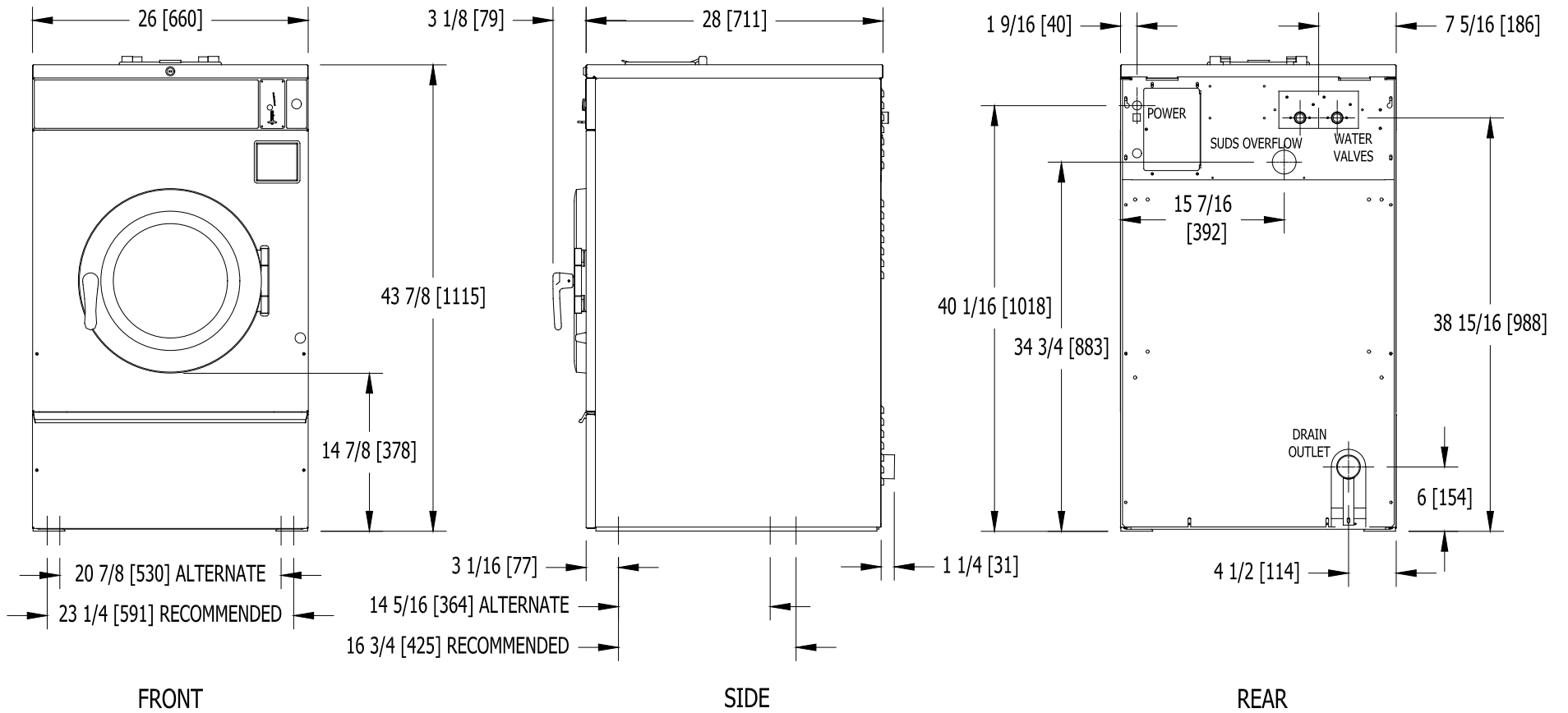

2.7.3 T-350 Commercial Washer Dimensions

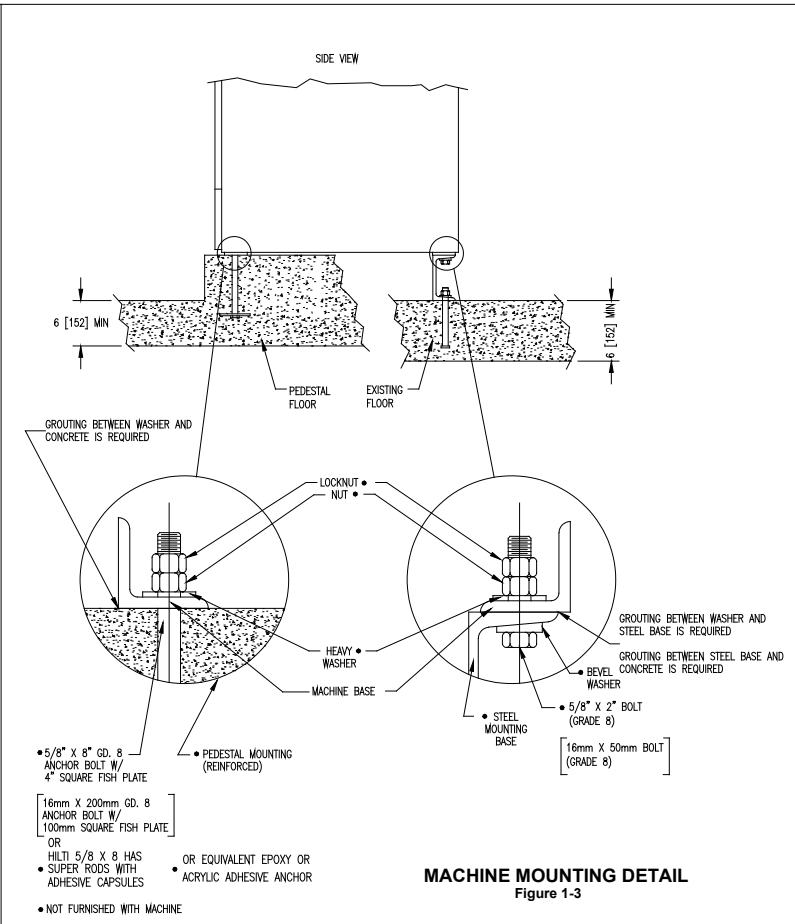
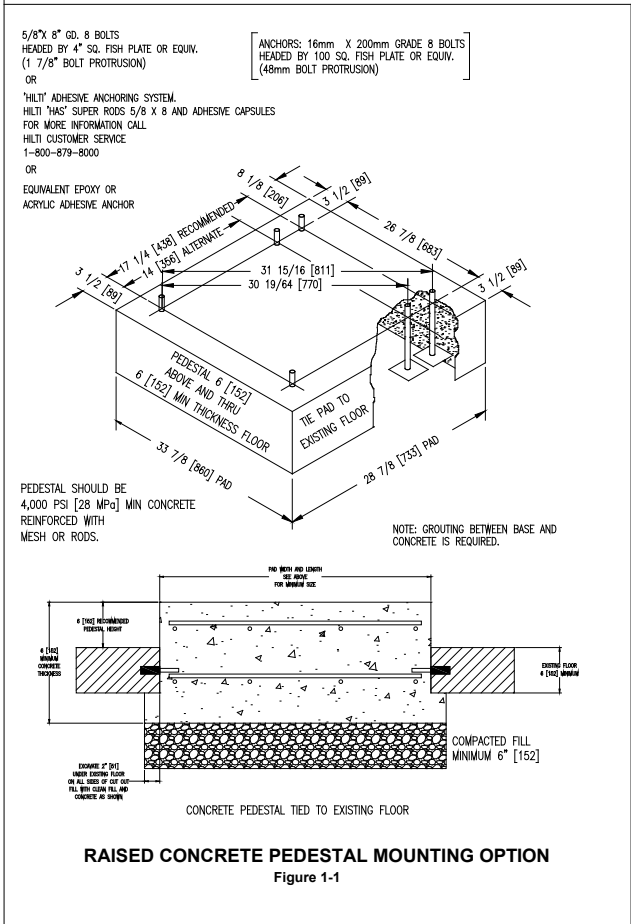
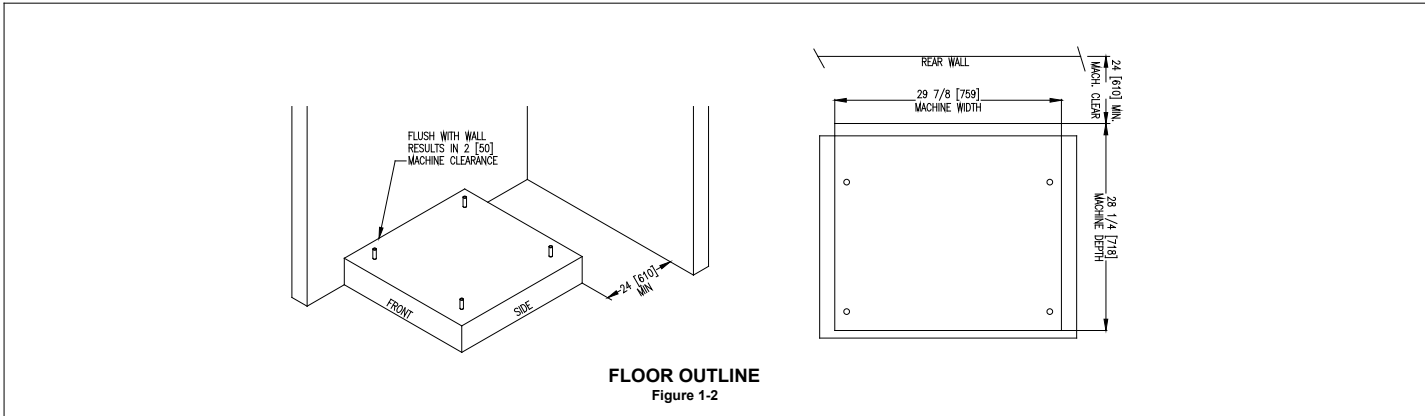

2.7.4 T-450 Machine Mounting Detail

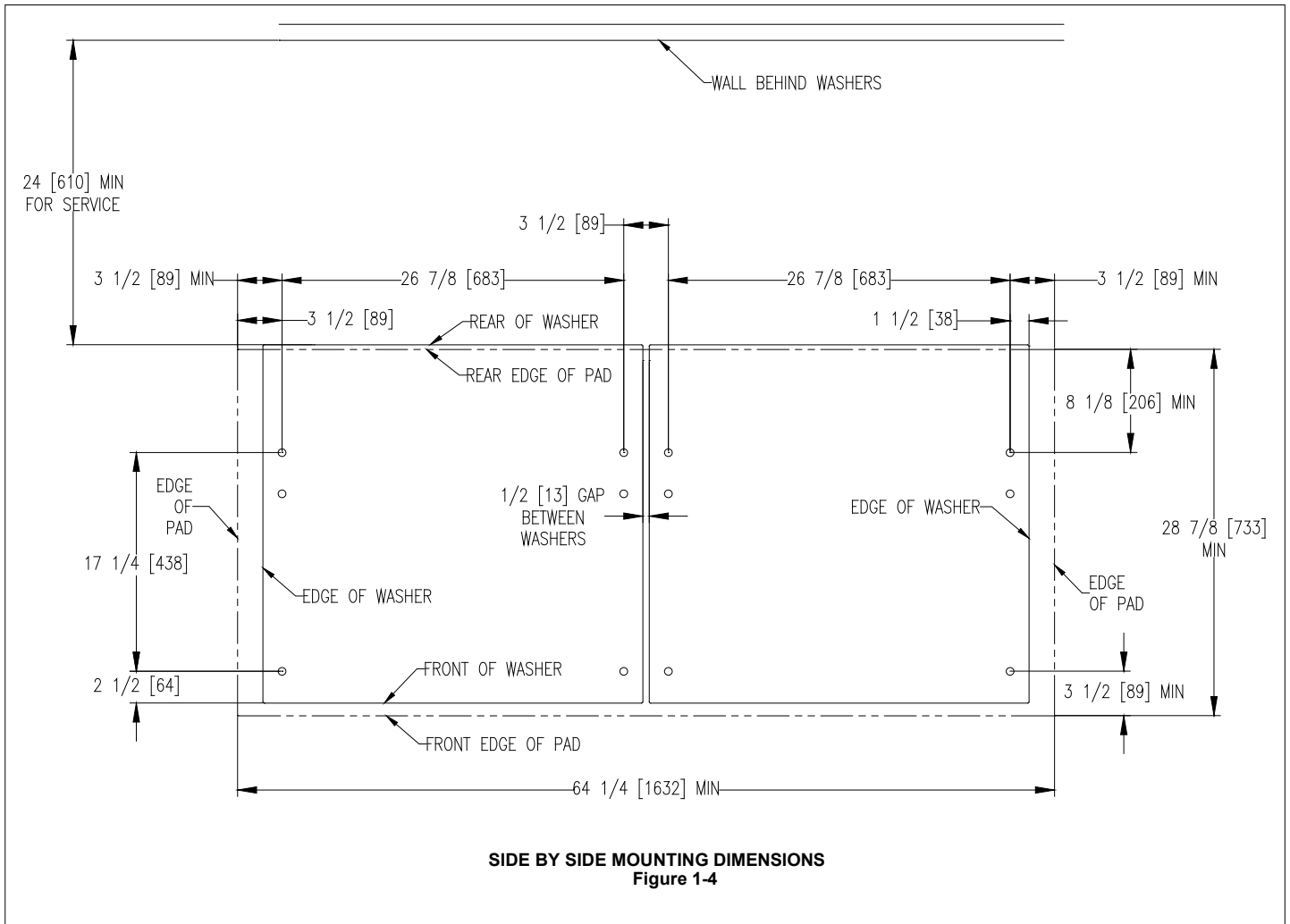

2.7.5 T-450 Side By Side Machine Mounting Detail

T-450 COMMERCIAL WASHER MOUNTING DIMENSIONS

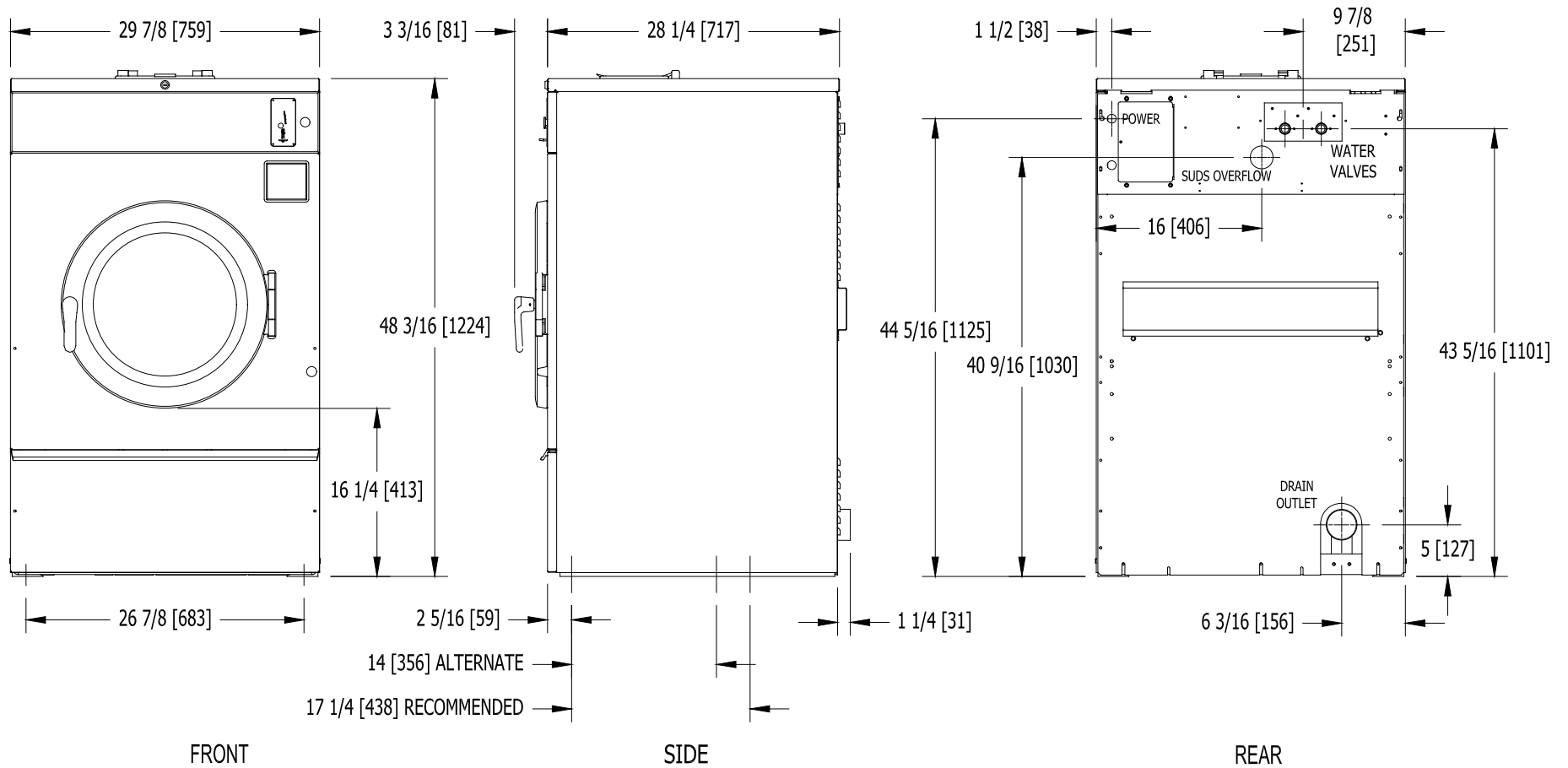

2.7.6 T-450 Commercial Washer Dimensions

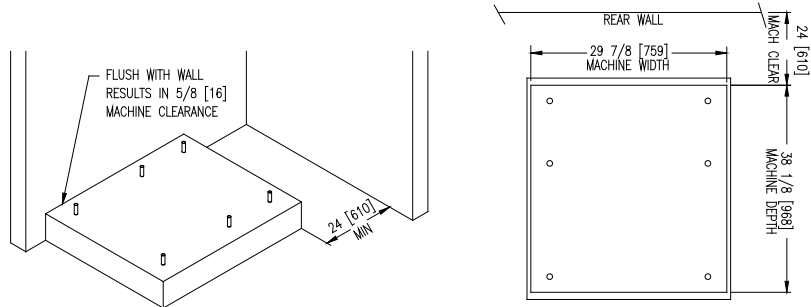

FLOOR OUTLINE
Figure 1-2

3/4" X 8" GD. 8 BOLTS
HEADED BY 4" SQ. FISH PLATE OR EQUIV.
(2 1/2" BOLT PROTRUSION)

OR

'HILTI' ADHESIVE ANCHORING SYSTEM.
HILTI 'HAS' SUPER RODS 3/4 X 10 AND ADHESIVE CAPSULES
FOR MORE INFORMATION CALL
HILTI CUSTOMER SERVICE
1-800-879-8000

OR

EQUIVALENT EPOXY OR
ACRYLIC ADHESIVE ANCHOR

19mm X 200mm GD. 8 BOLTS
HEADED BY 100mm SQ. FISH PLATE
OR EQUIV.
(64mm BOLT PROTRUSION)

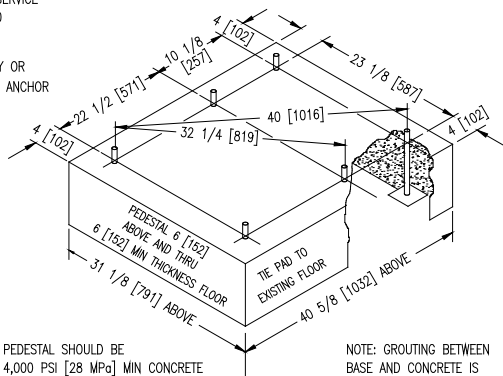

PEDESTAL SHOULD BE
4,000 PSI [28 MPa] MIN CONCRETE
REINFORCED WITH
MESH OR RODS.

NOTE: GROUTING BETWEEN
BASE AND CONCRETE IS
REQUIRED.

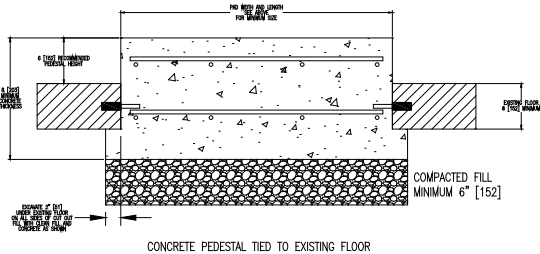

RAISED CONCRETE PEDESTAL MOUNTING OPTION
Figure 1-1

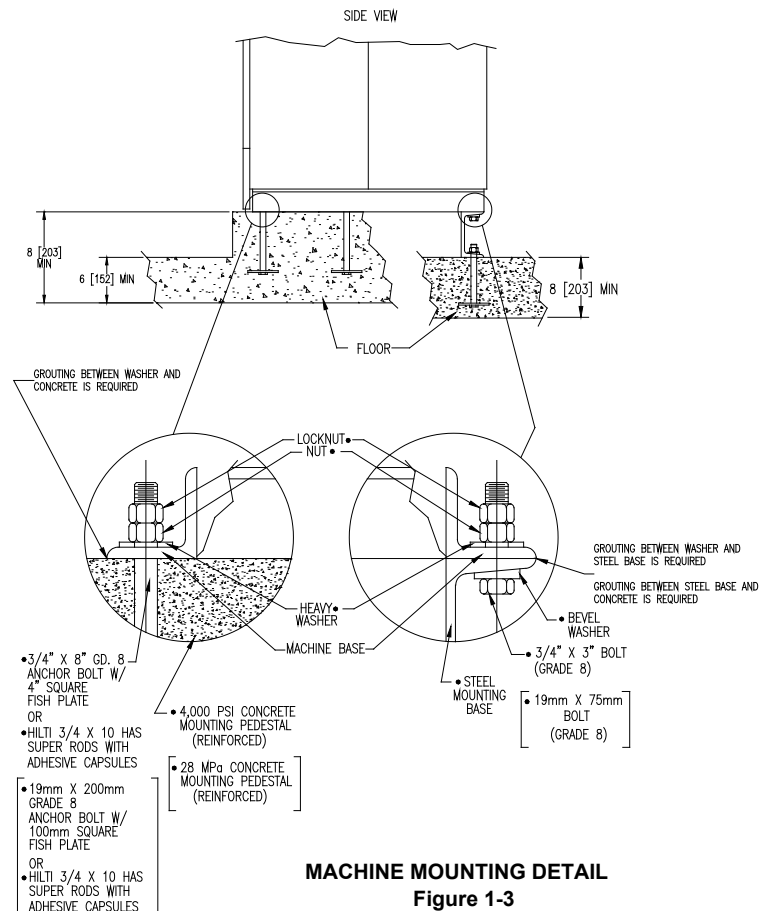

MACHINE MOUNTING DETAIL
Figure 1-3

•OR EQUIVALENT EPOXY OR ACRYLIC ADHESIVE ANCHOR
•NOT FURNISHED WITH MACHINE

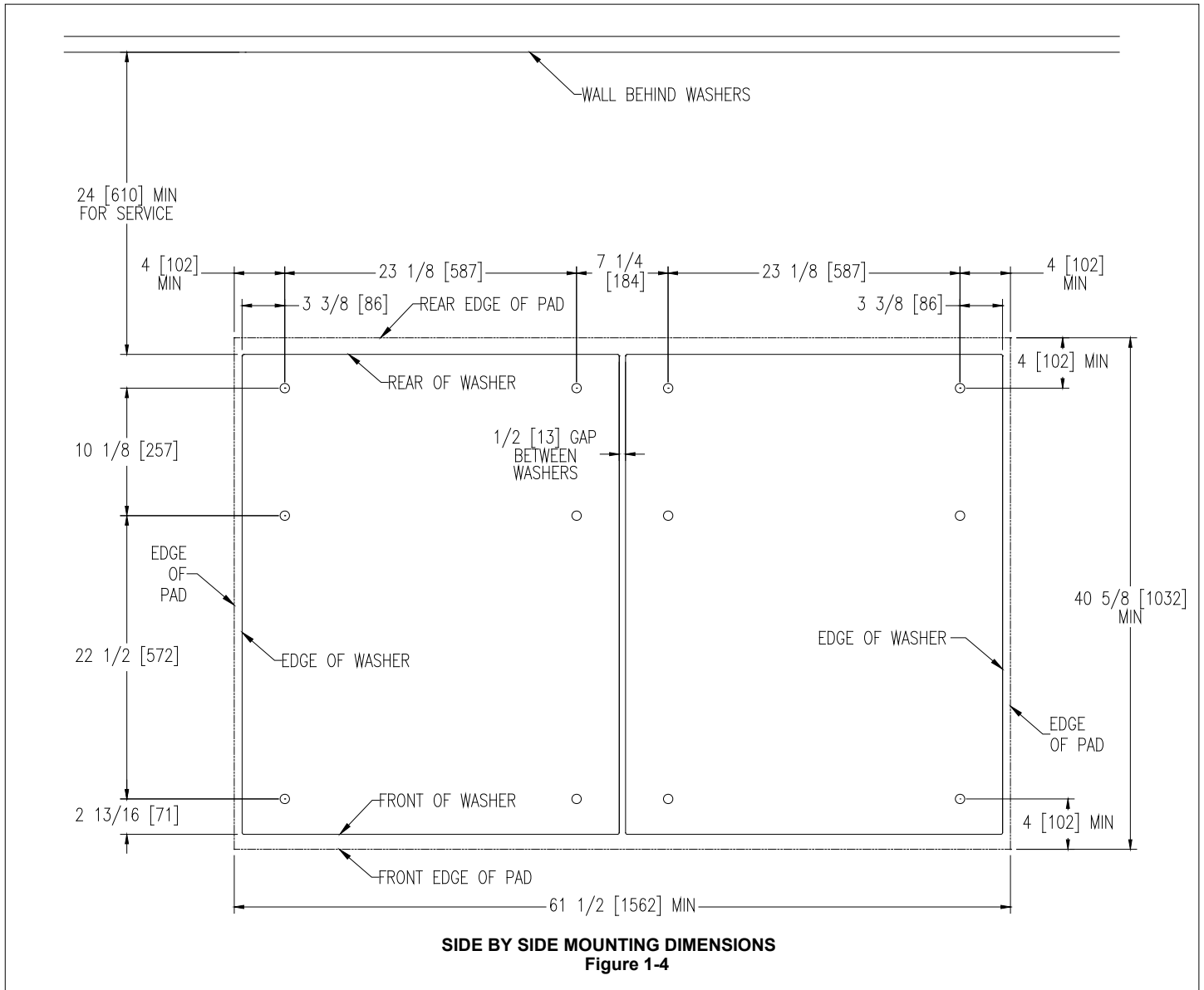

2.7.8 T-650 Machine Side By Side Mounting Detail

T-650 COMMERCIAL WASHER MOUNTING DIMENSIONS

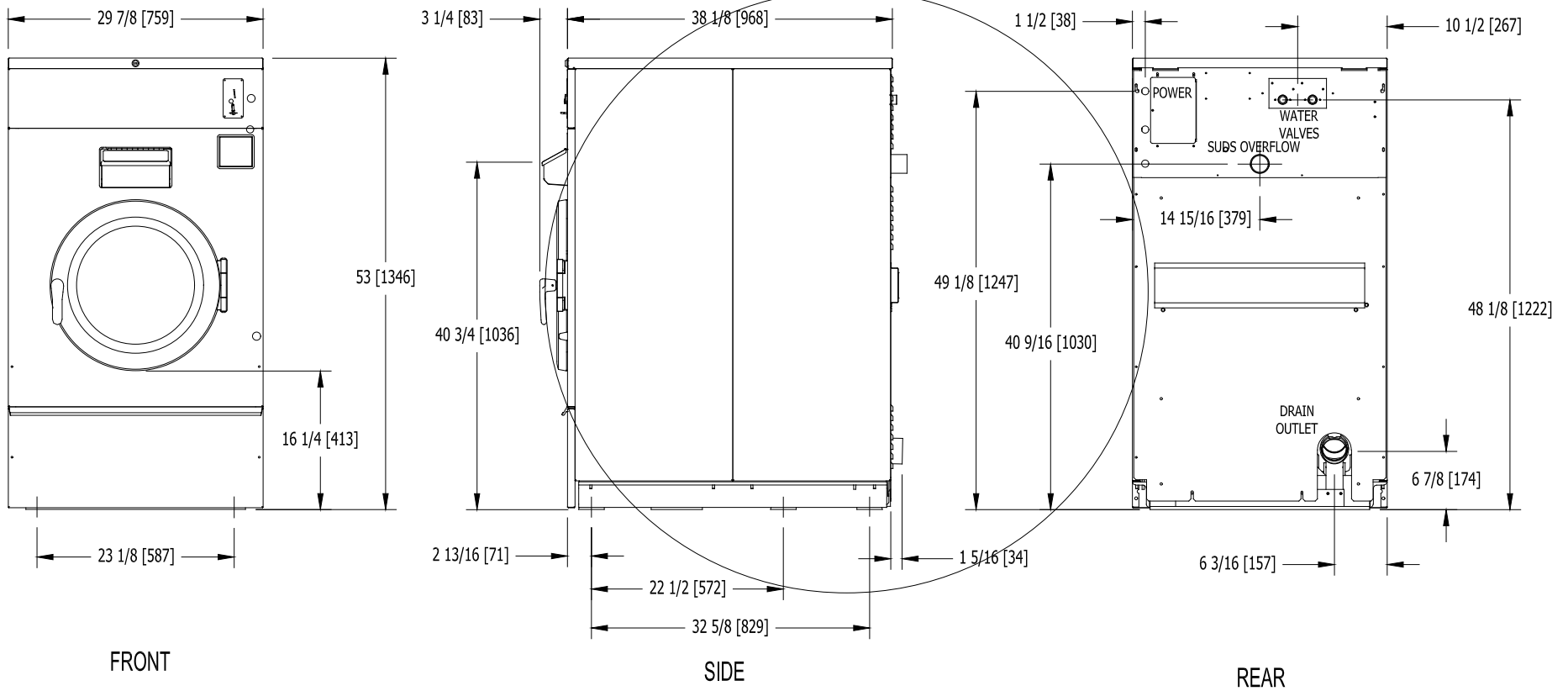

2.7.9 T-650 Commercial Washer Dimensions

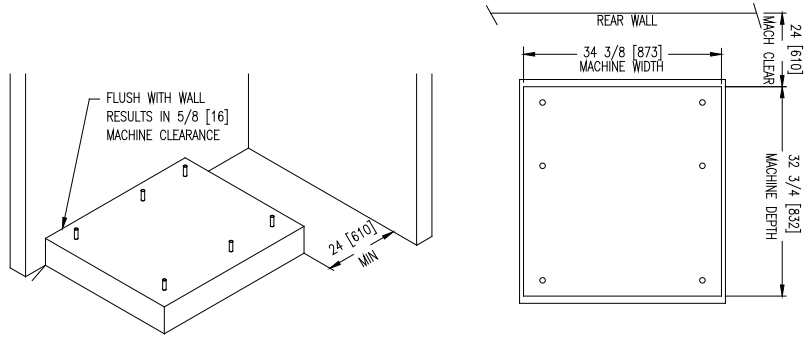

FLOOR OUTLINE
Figure 1-2

3/4" X 8" GD. 8 BOLTS HEADED BY 4" SQ. FISH PLATE OR EQUIV. (2 1/2" BOLT PROTRUSION)

[ANCHORS: 19mm X 200mm GRADE 8 BOLTS HEADED BY 102mm SQ. FISH PLATE OR EQUIV. (64mm BOLT PROTRUSION)]

OR

"HILTI" ADHESIVE ANCHORING SYSTEM.
HILTI "HAS" SUPER RODS 3/4 X 10 AND ADHESIVE CAPSULES
FOR MORE INFORMATION CALL
HILTI CUSTOMER SERVICE
1-800-879-8000

OR

EQUIVALENT EPOXY OR ACRYLIC ADHESIVE ANCHOR

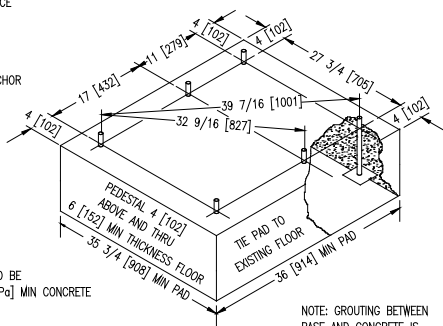

PEDESTAL SHOULD BE 4,000 PSI [28 MPa] MIN CONCRETE REINFORCED WITH MESH OR RODS.

NOTE: GROUTING BETWEEN BASE AND CONCRETE IS REQUIRED.

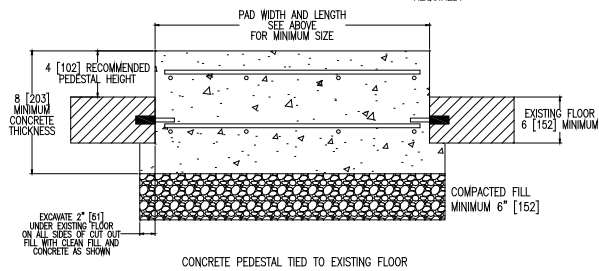

RAISED CONCRETE PEDESTAL MOUNTING OPTION
Figure 1-1

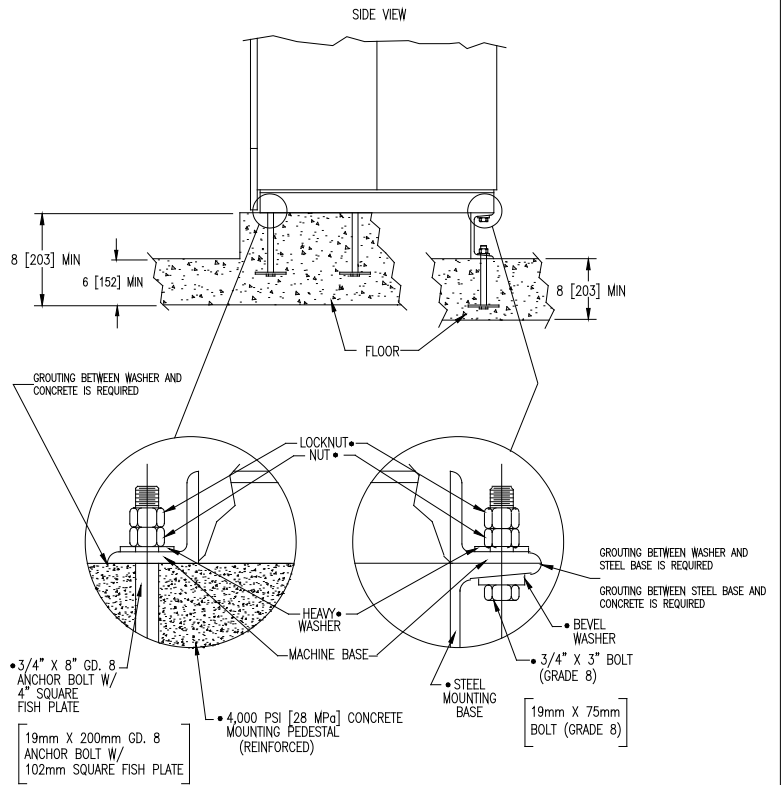

MACHINE MOUNTING DETAIL
Figure 1-3

OR

"HILTI" 3/4 X 10 HAS SUPER RODS WITH ADHESIVE CAPSULES

• NOT FURNISHED WITH MACHINE

2.7.10 T-750 Machine Mounting Detail

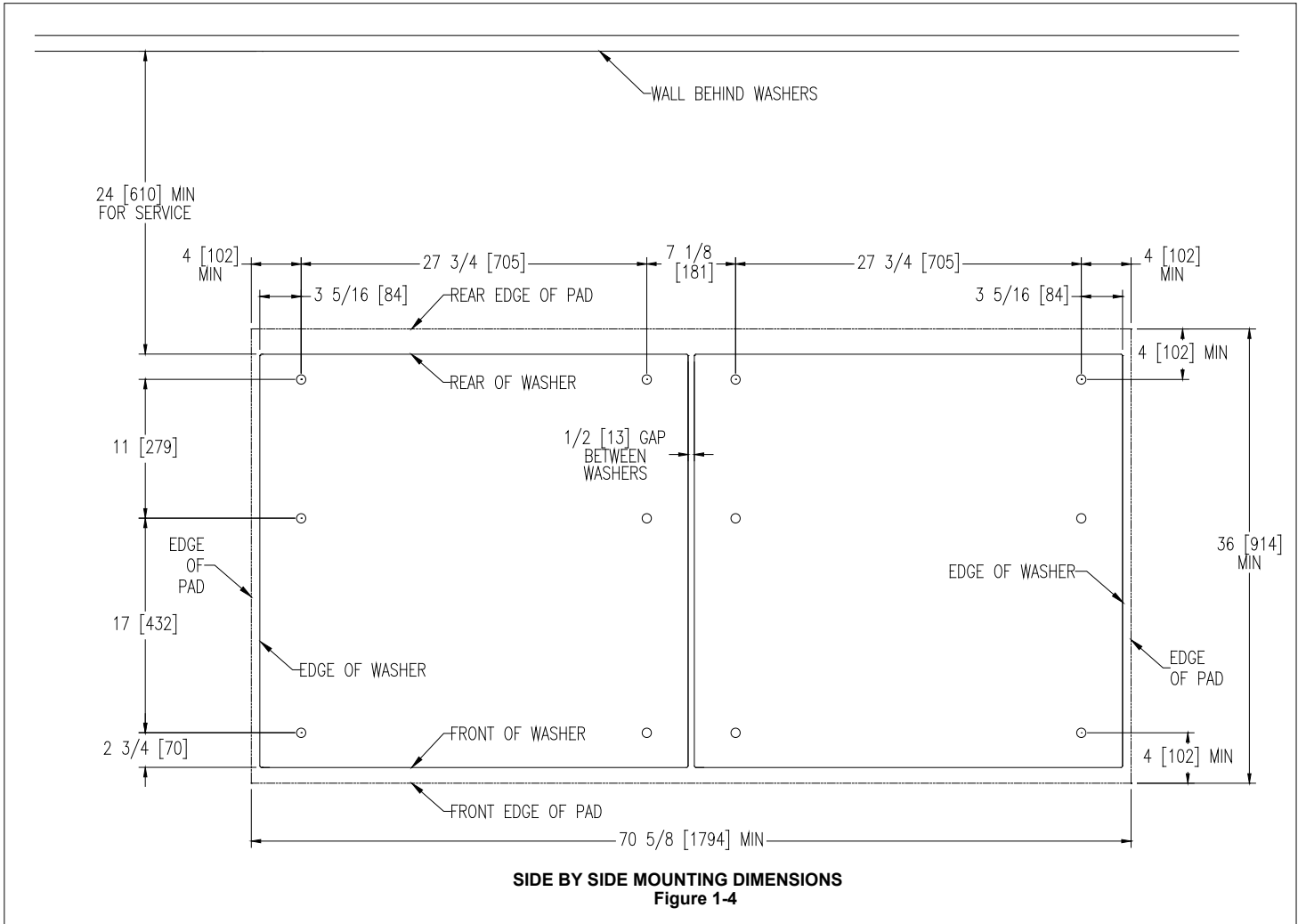

2.7.11 T-750 Machine Side By Side Mounting Detail

T-750 COMMERCIAL WASHER MOUNTING DIMENSIONS

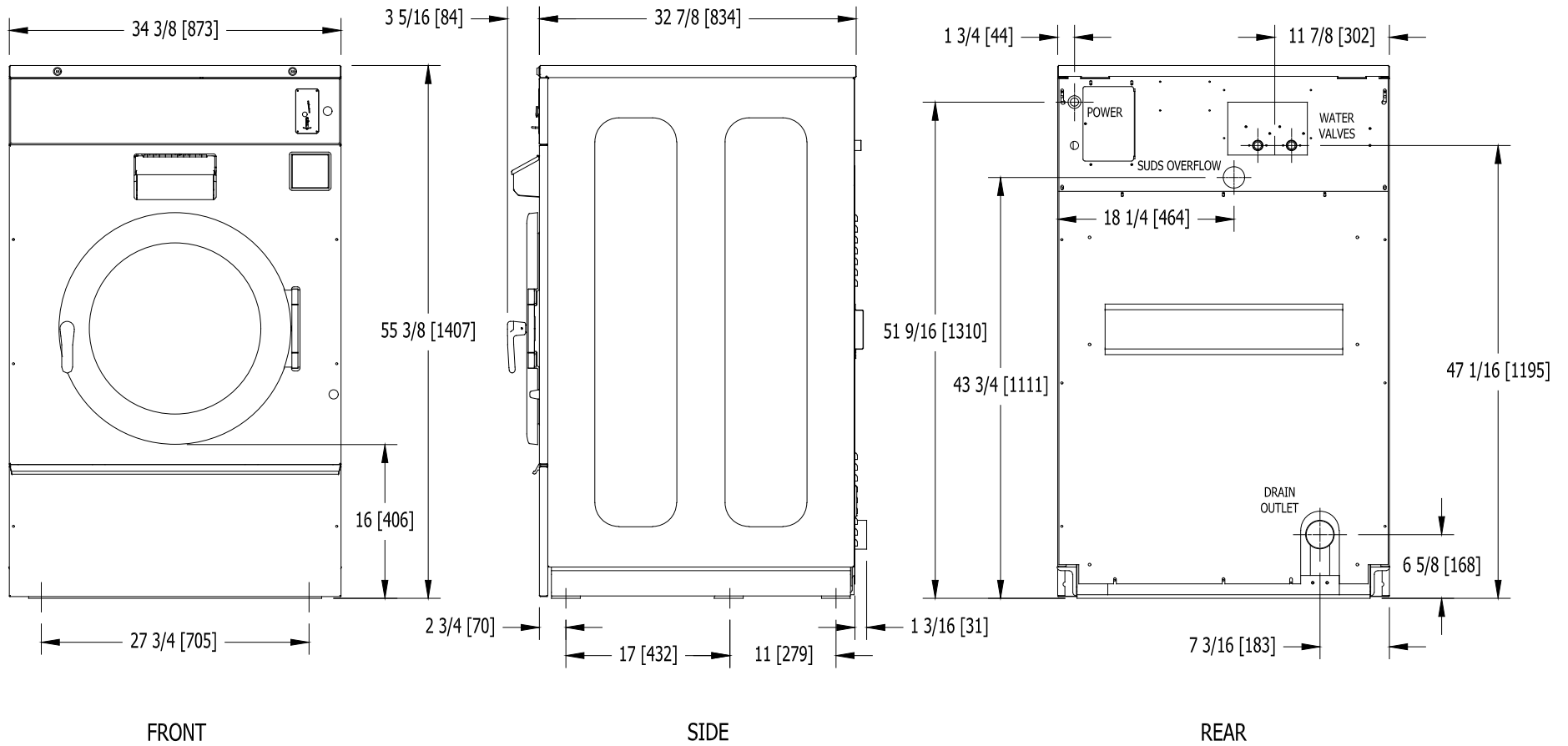

2.7.12 T-750 Commercial Washer Dimensions

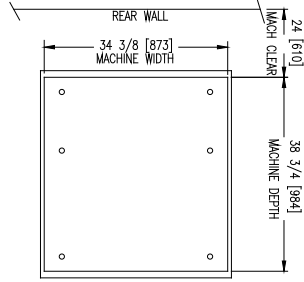
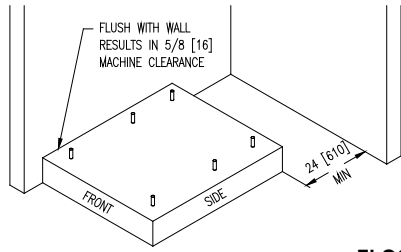

FLOOR OUTLINE
Figure 1-2

3/4" X 8" GD. 8 BOLTS HEADED BY 4" SQ. FISH PLATE OR EQUIV. (2 1/2" BOLT PROTRUSION)

ANCHORS: 19mm X 200mm GRADE 8 BOLTS HEADED BY 102mm SQ. FISH PLATE OR EQUIV. (64mm BOLT PROTRUSION)

OR
'HILTI' ADHESIVE ANCHORING SYSTEM.
HILTI 'HAS' SUPER RODS 3/4 X 10 AND ADHESIVE CAPSULES
FOR MORE INFORMATION CALL
HILTI CUSTOMER SERVICE
1-800-879-8000

OR
EQUIVALENT EPOXY OR
ACRYLIC ADHESIVE ANCHOR

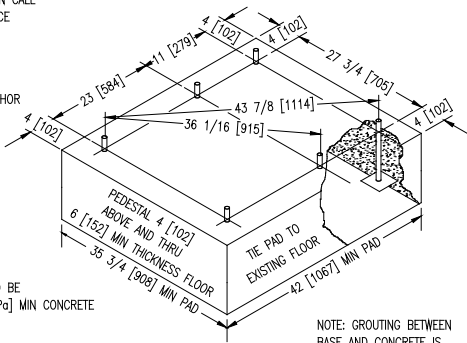

PEDESTAL SHOULD BE 4,000 PSI [28 MPa] MIN CONCRETE REINFORCED WITH MESH OR RODS.

NOTE: GROUTING BETWEEN BASE AND CONCRETE IS REQUIRED.

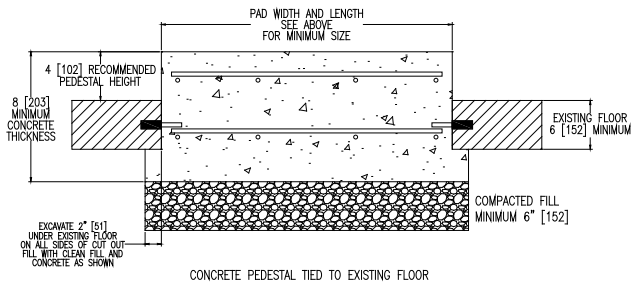

CONCRETE PEDESTAL TIED TO EXISTING FLOOR

RAISED CONCRETE PEDESTAL MOUNTING OPTION
Figure 1-1

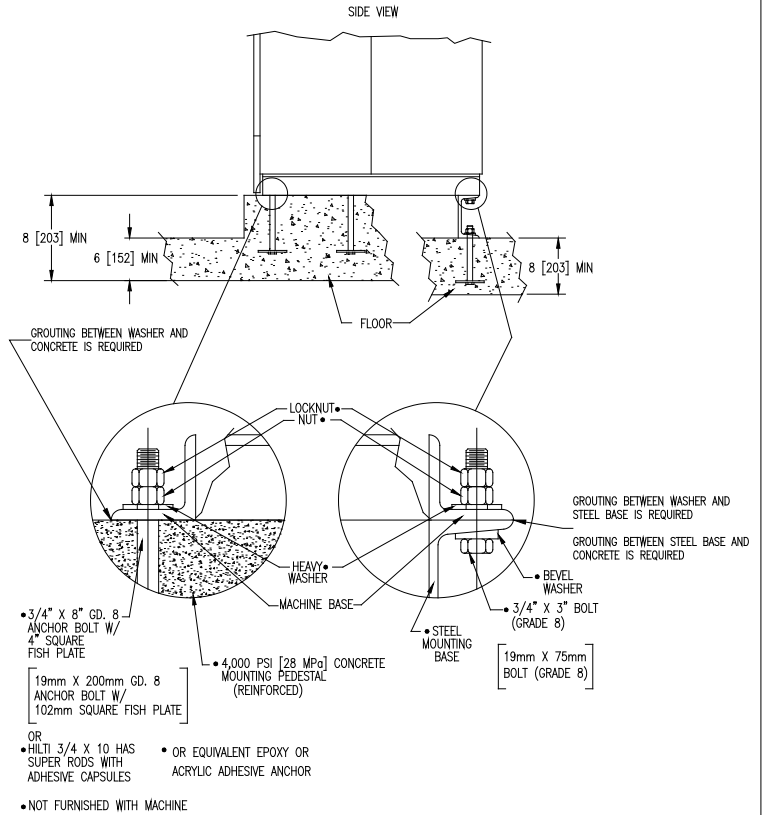

• 3/4" X 8" GD. 8 ANCHOR BOLT W/ 4" SQUARE FISH PLATE
• 19mm X 200mm GD. 8 ANCHOR BOLT W/ 102mm SQUARE FISH PLATE

• 4,000 PSI [28 MPa] CONCRETE MOUNTING PEDESTAL (REINFORCED)

• 3/4" X 3" BOLT (GRADE 8)
• 19mm X 75mm BOLT (GRADE 8)

OR
• HILTI 3/4 X 10 HAS SUPER RODS WITH ADHESIVE CAPSULES
• OR EQUIVALENT EPOXY OR ACRYLIC ADHESIVE ANCHOR

• NOT FURNISHED WITH MACHINE

MACHINE MOUNTING DETAIL
Figure 1-3

2.7.13 T-950 Machine Mounting Detail

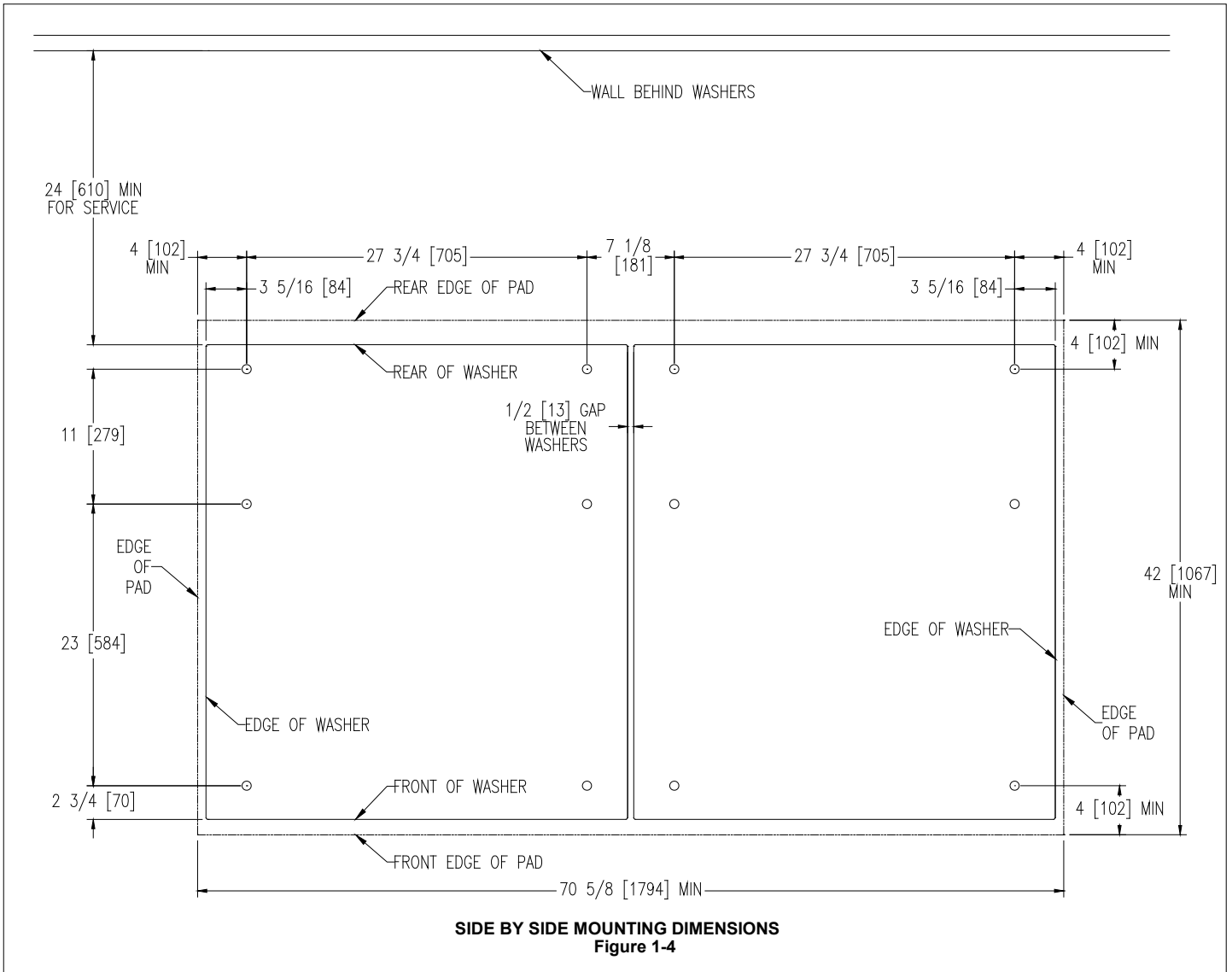

2.7.14 T-950 Machine Side By Side Mounting Detail

T-950 COMMERCIAL WASHER
MOUNTING DIMENSIONS

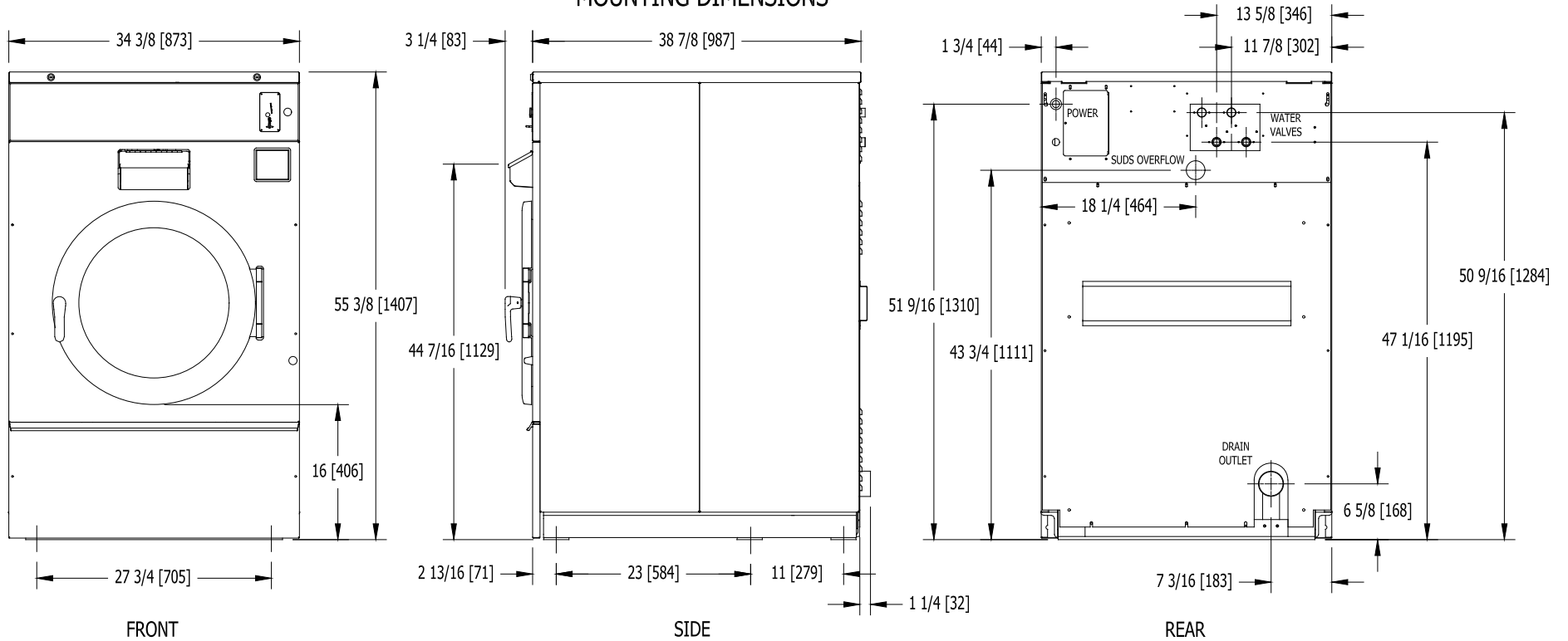

2.7.15 T-950 Commercial Washer Dimensions

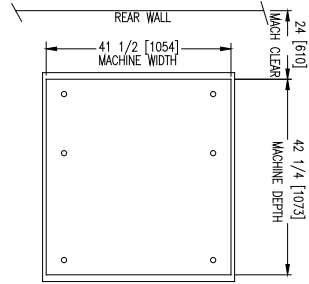
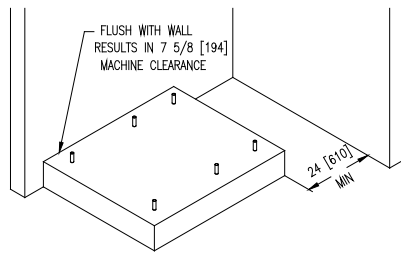

FLOOR OUTLINE
Figure 1-2

3/4" X 8" GD. 8 BOLTS HEADED BY 4" SQ. FISH PLATE OR EQUIV. (2 1/2" BOLT PROTRUSION)

ANCHORS: 19mm X 200mm GRADE 8 BOLTS HEADED BY 102mm SQ. FISH PLATE OR EQUIV. (64mm BOLT PROTRUSION)

OR
'HILTI' ADHESIVE ANCHORING SYSTEM.
HILTI 'HAS' SUPER RODS 3/4 X 10 AND ADHESIVE CAPSULES
FOR MORE INFORMATION CALL
HILTI CUSTOMER SERVICE
1-800-879-8000

OR
EQUIVALENT EPOXY OR
ACRYLIC ADHESIVE ANCHOR

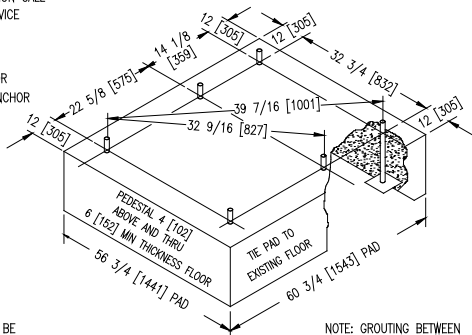

PEDESTAL SHOULD BE
4,000 PSI [28 MPa] MIN CONCRETE
REINFORCED WITH
MESH OR RODS.

NOTE: GROUTING BETWEEN
BASE AND CONCRETE IS
REQUIRED.

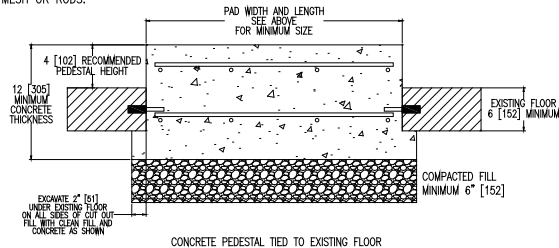

RAISED CONCRETE PEDESTAL MOUNTING OPTION
Figure 1-1

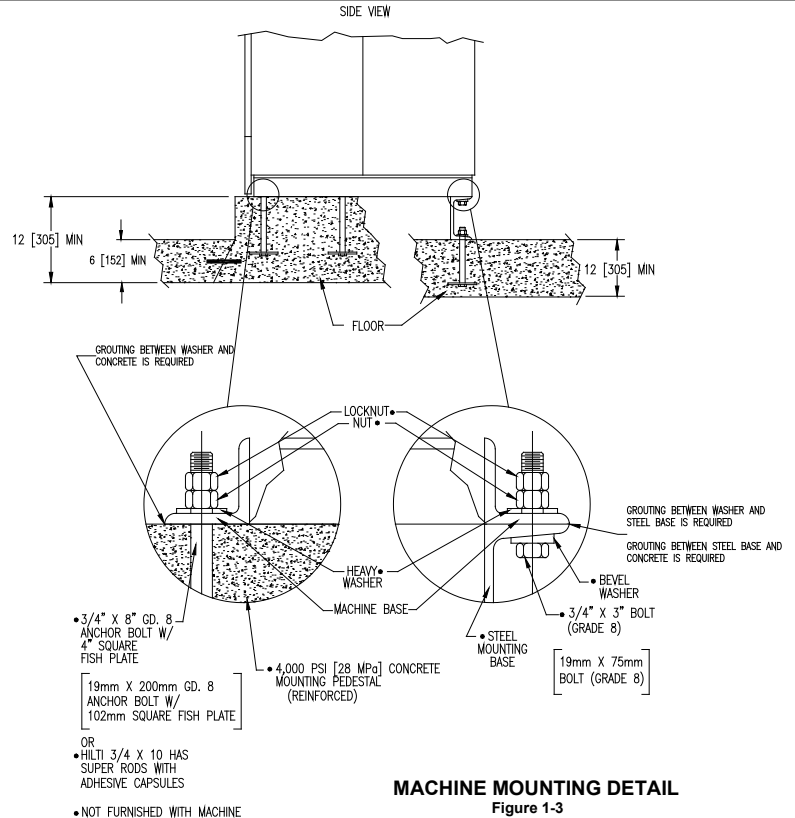

MACHINE MOUNTING DETAIL
Figure 1-3

2.7.16 T-1450 Machine Mounting Detail

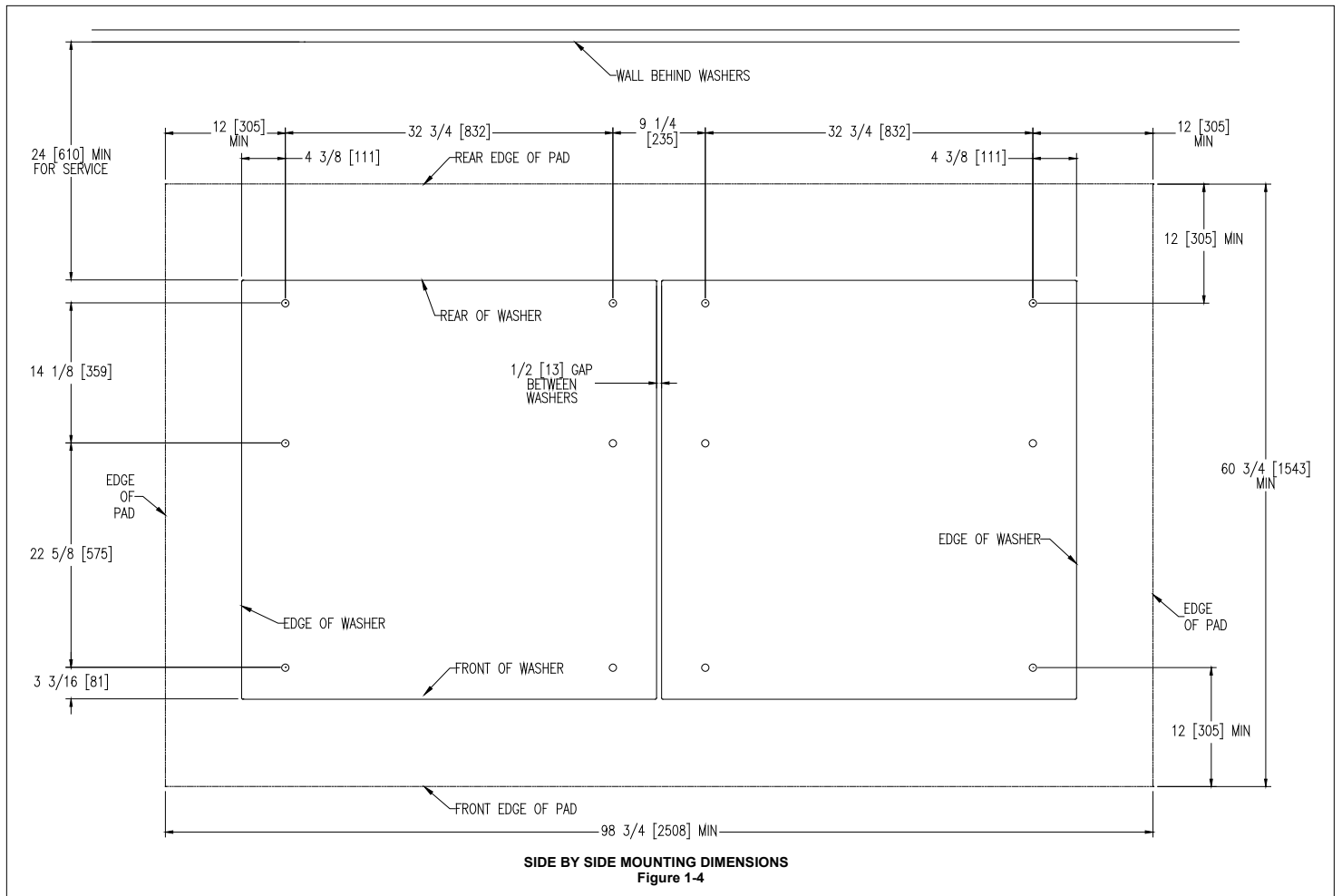

2.7.17 T-1450 Machine Side By Side Mounting Detail

T-1450 COMMERCIAL WASHER
MOUNTING DIMENSIONS

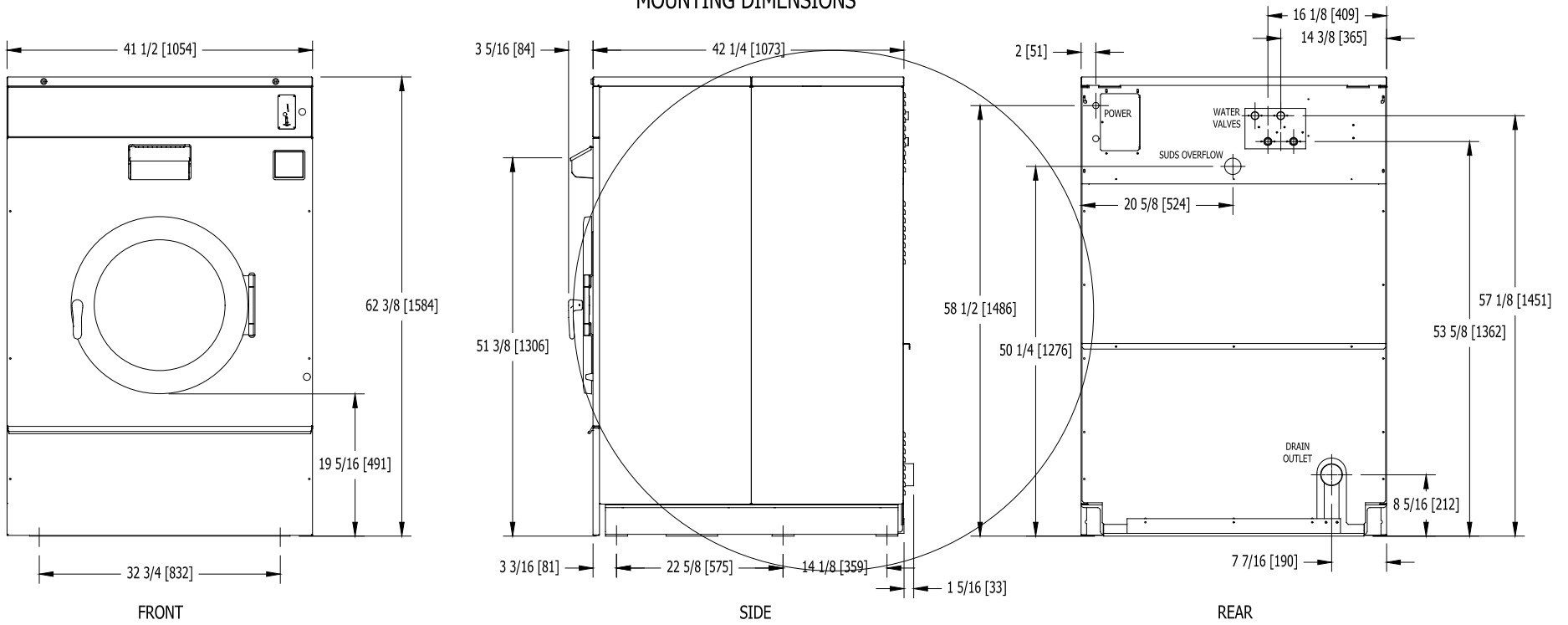

2.7.18 T-1450 Commercial Washer Dimensions

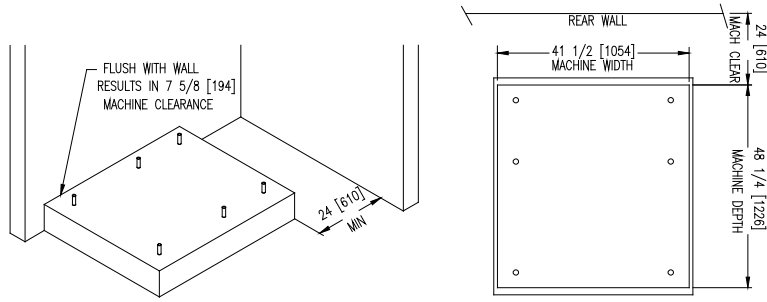

FLOOR OUTLINE
Figure 1-2

3/4" X 8" GD. 8 BOLTS HEADED BY 4" SQ. FISH PLATE OR EQUIV. (2 1/2" BOLT PROTRUSION)

ANCHORS: 19mm X 200mm GRADE 8 BOLTS HEADED BY 102mm SQ. FISH PLATE OR EQUIV. (64mm BOLT PROTRUSION)

OR
'HILTI' ADHESIVE ANCHORING SYSTEM
HILTI 'HAS' SUPER RODS 3/4 X 10 AND ADHESIVE CAPSULES
FOR MORE INFORMATION CALL

HILTI CUSTOMER SERVICE
1-800-879-8000

OR
EQUIVALENT EPOXY OR
ACRYLIC ADHESIVE ANCHOR

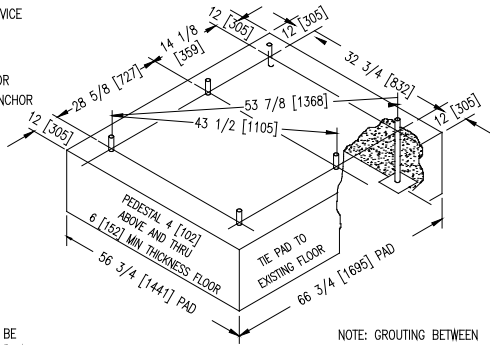

PEDESTAL SHOULD BE 4,000 PSI [28 MPa] MIN CONCRETE REINFORCED WITH MESH OR RODS.

NOTE: GROUTING BETWEEN BASE AND CONCRETE IS REQUIRED.

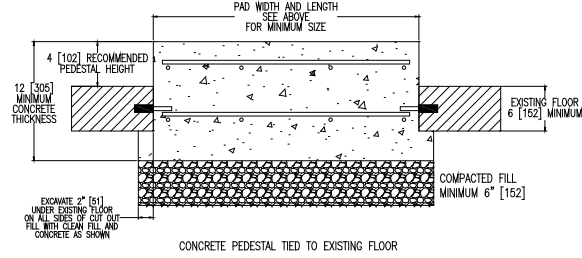

RAISED CONCRETE PEDESTAL MOUNTING OPTION
Figure 1-1

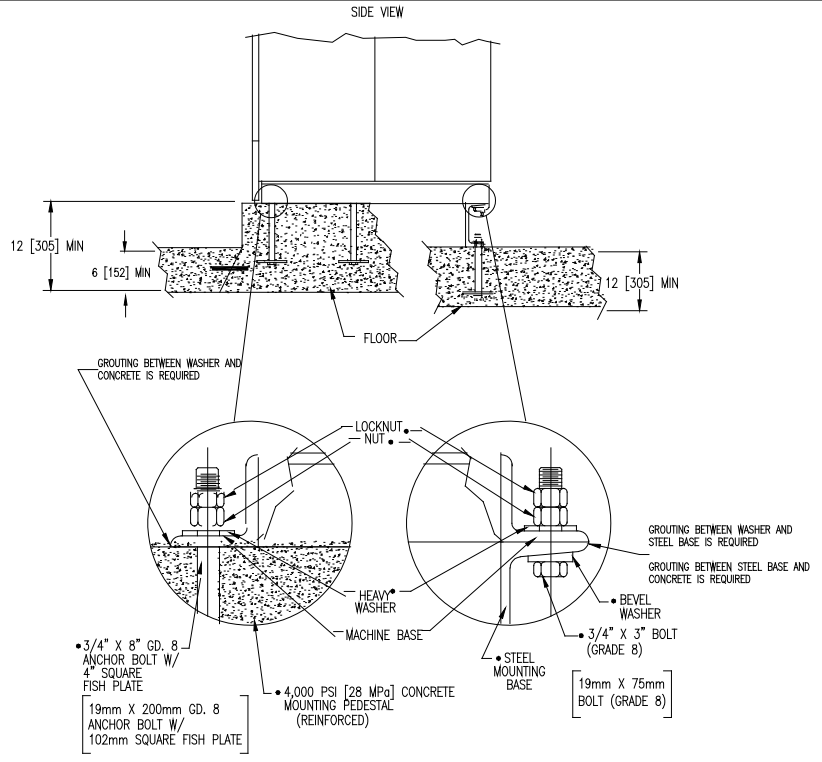

OR
• HILTI 3/4 X 10 HAS SUPER RODS WITH ADHESIVE CAPSULES
• NOT FURNISHED WITH MACHINE

MACHINE MOUNTING DETAIL
Figure 1-3

2.7.19 T-1800 Machine Mounting Detail

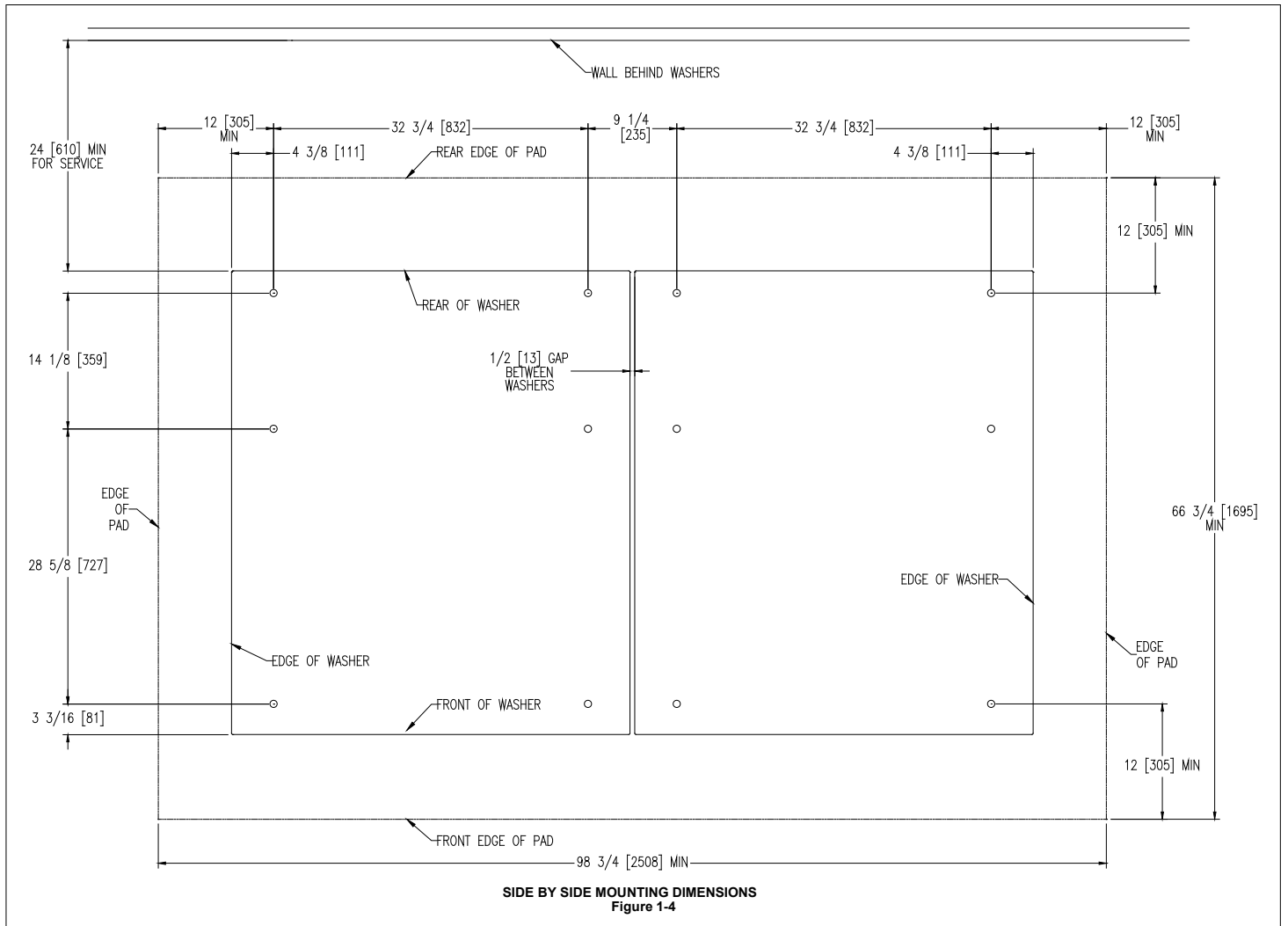

2.7.20 T-1800 Machine Side By Side Mounting Detail

T-1800 COMMERCIAL WASHER
MOUNTING DIMENSIONS

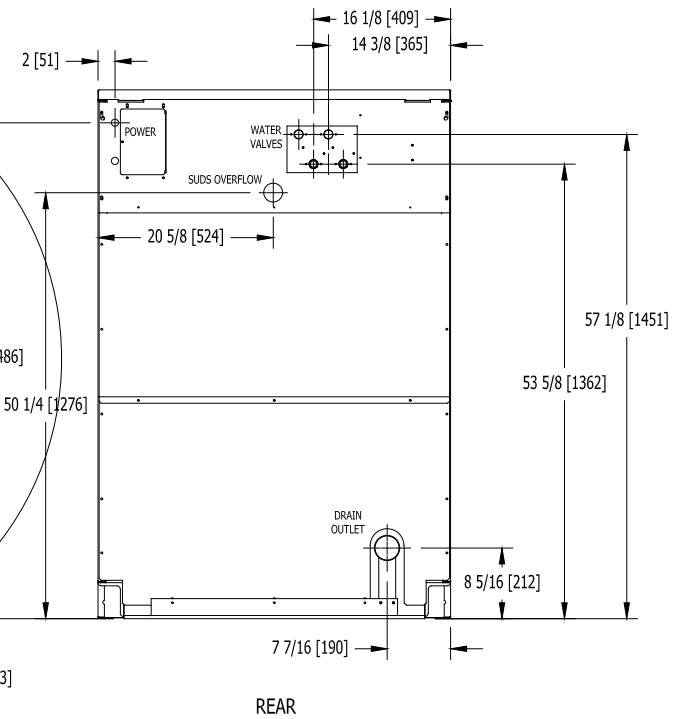
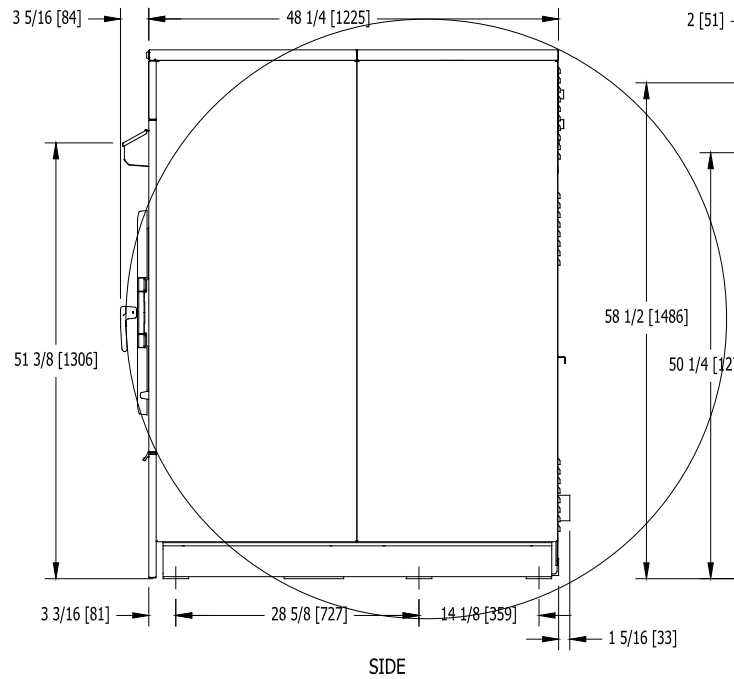
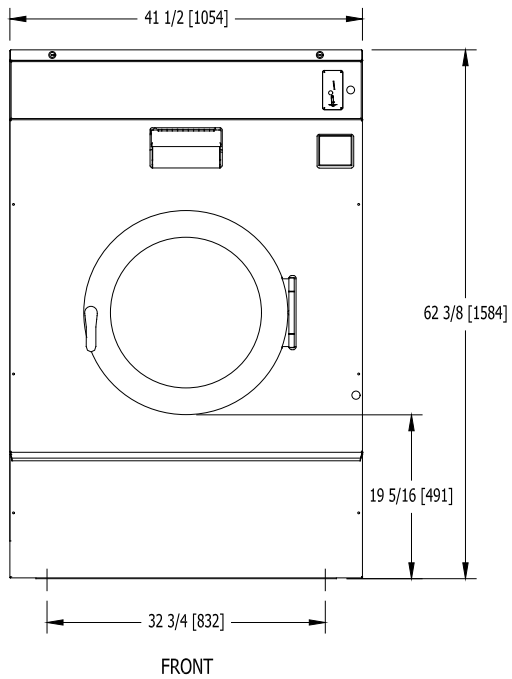

2.7.21 T-1800 Commercial Washer Dimensions

2.8 PLUMBING

Water supply hoses are provided with each machine. The threaded connections on the hoses are $\frac{3}{4}$ -11 $\frac{1}{2}$ NHT for 60 Hz models and $\frac{3}{4}$ -14 BSP for 50 Hz models.

Separate hot and cold water lines must be supplied to the machine, maintaining 30 psi to 120 psi (207 kPa to 827 kPa) water flow pressure. A 140°F (60°C) hot water supply is recommended for best washing results. Do not exceed 180°F (82°C) water temperature.

2.9 DRAIN

The drain outlet tube size:

For T-350 is 2 $\frac{1}{4}$ inches (57 mm) in diameter, and for all other models is 3 inches (76 mm) in diameter.

Any drain hose used must be lower than the drain valve to assure proper draining.

2.10 PROTECTIVE FILM

The machine may have protective adhesive film on the front control panel label area and on the front, top, and side stainless steel panels. The film may be peeled off before putting the machine into service.

2.11 ELECTRICAL

The Dexter washing machines are intended to be permanently installed appliances. No power cord is provided. The machine should be connected to an individual branch circuit not shared by lighting or other equipment. A means for disconnection with a contact separation of at least 1/8" (3 mm) must be provided. The connection should be sheathed in liquid-tight or approved flexible conduit, or equivalent, with conductors of the proper size and insulation (50 Hz: The sheath of the supply cord must be at least equivalent to that of a cord complying with IEC 227 or IEC 245). A qualified technician should make such connections in accordance with the wiring diagram. See specification sheet for minimum recommended wire size.

Individual circuit breakers for each unit are required. Do not use ground-fault (earth-fault) circuit breakers or ground-fault (earth-fault) circuit interrupter outlets.

WARNING:
**SHUT OFF POWER AND WATER BEFORE OPENING ANY SERVICE
PANELS.**

POWER
CONNECTIONS

L1



L2



L3



N

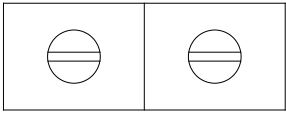

ELECTRICAL CONNECTIONS

2.11.1 INSTALLING THE ELECTRICAL CONNECTION

- 2.11.1.1 Disconnect all power to the washer.
- 2.11.1.2 Remove the top panel of the washer and locate the power terminal block near the back of the control compartment.
- 2.11.1.3 If power is 120V-1PH-60Hz, connect L1, N and Ground.
- 2.11.1.4 If power is 208-240V-**3PH**-60Hz, connect L1, L2, L3 and Ground. If there is a high leg, it must NOT be connected to L1 or L2. However, failure due to a voltage surge on the high leg is not covered by equipment warranty. Contact Dexter Laundry with any questions.
- 2.11.1.5 If power is 208-240V-**1PH**-60Hz, connect L1, L2 and Ground.
- 2.11.1.6 If power is 230V-**1PH**-50Hz, connect L1, N and Earth.

NOTE: It is important that the grounding screw next to the power terminal block be connected to a good external ground.

2.11.2 FUSING REQUIREMENTS

Single- and Three -phase models:

See specification sheet for required TIME-DELAY (DUAL ELEMENT) FUSE size (or equivalent circuit breaker)

2.11.3 CONTROLS TRANSFORMER (208-240V 60 Hz models only)

The controls transformer is located inside the control trough and steps a range of 208 to 240 volts down to 115 volts. There are two terminals on the controls transformer for the primary (incoming) power. Use the terminal marked "208V" for power supplies between 208 and 219 volts. Use the terminal marked "240V" for power supplies between 220 and 240 volts. Refer to the following for control transformer connections.

CONTROL TRANSFORMER CONNECTIONS

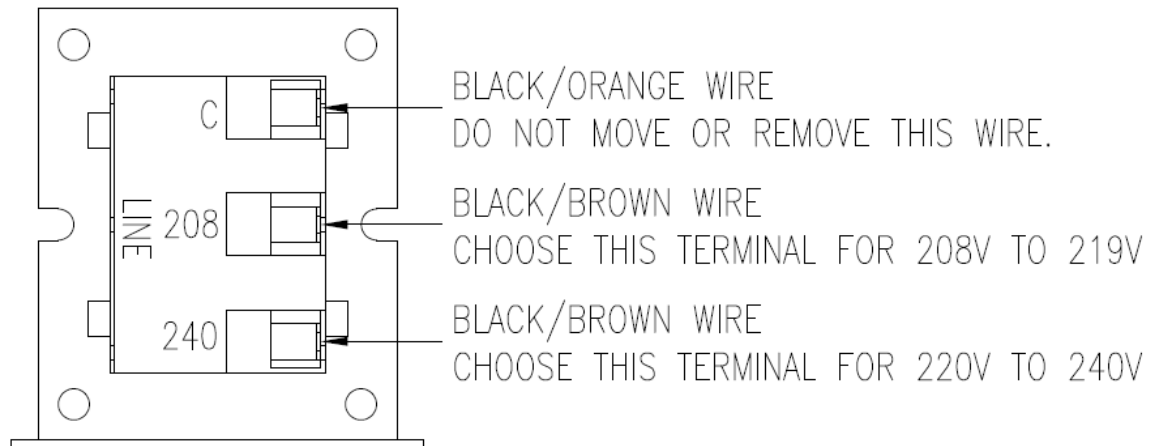

60 Hz Control Transformer Connections

2.11.4 CONTROLS TRANSFORMER (230V 50 Hz models only)

The controls transformer is located inside the control trough and steps a range of 180 to 255 volts down to 24 volts. There are two terminals on the controls transformer for the primary (incoming) power. Use the terminal marked "L1 200V" for power supplies between 180 and 229 volts. Use the terminal marked "L1 230V" for power supplies between 230 and 255 volts.

CONTROL TRANSFORMER CONNECTIONS

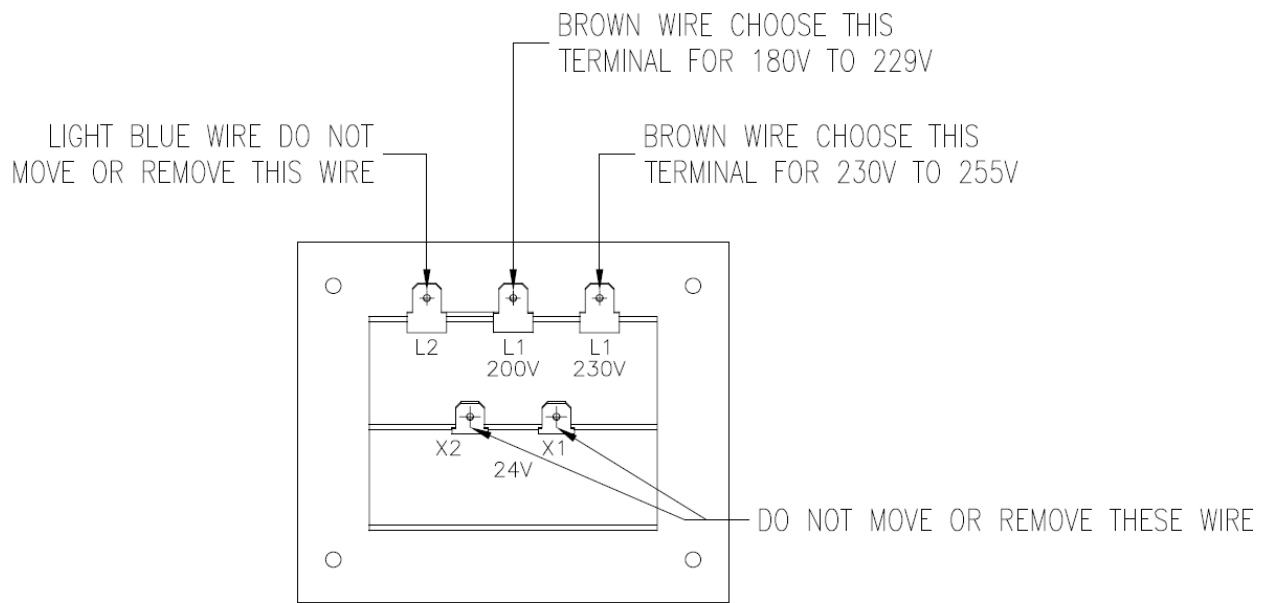

50 Hz Control Transformer Connections

2.11.5 VARIABLE FREQUENCY DRIVE ADJUSTMENTS (208-240V 60 Hz T-950 model only)

The variable frequency drive allows for varying acceleration during Final Spin on T-950 models. It is important to utilize a decreased acceleration rate when the application power is low. This acceleration rate is determined by a white wire jumper installed on the drive terminal block from +10V to AVI. Reference the diagram below for terminal block locations.

Remove the wire jumper when input power is between 208 and 219 volts. Keep the jumper installed when input power is between 220 and 240 volts. Reference the drawings below for the jumper location.

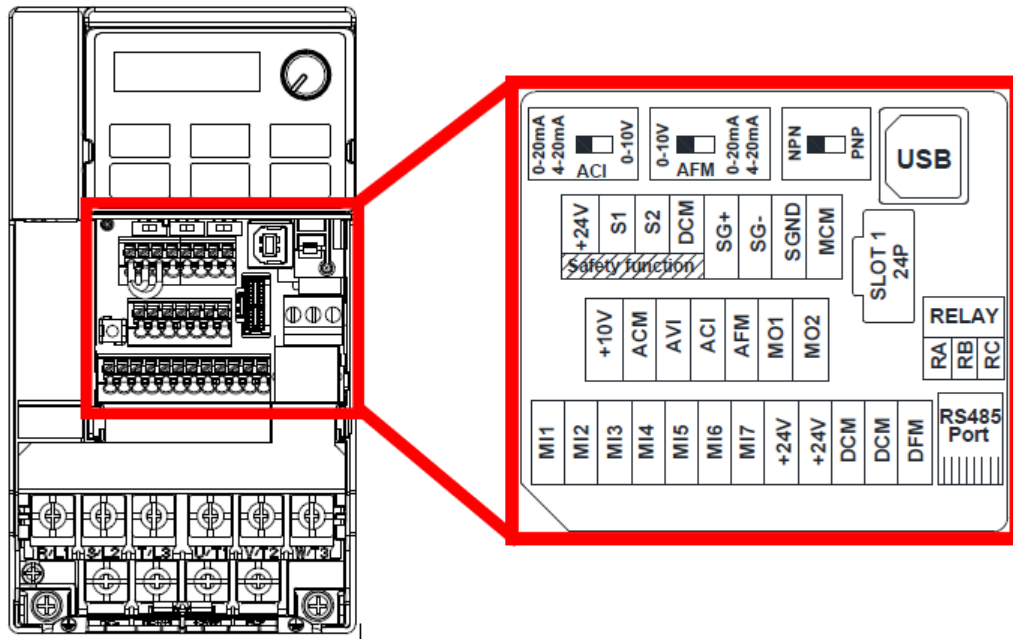

Control Terminations on Variable Frequency Drive

X Series Washer Model	Max Spin Speed	Input Voltage	Jumper Terminal Locations on Variable Frequency Drive (VFD)														
			MI1	MI2	MI3	MI4	MI5	MI6	DCM (Left)	DCM (Right)	24V	ACM	AVI	ACI	10V	M01	
T-950	200G	240V												X		X	
	200G	208V	No Jumper required														

2.12 OPERATION CHECK

After all mounting, plumbing and electrical work is completed, run the machine through a complete wash cycle. Check for water leaks and verify proper operation.

During intermediate spin and final spin, the cylinder should turn in a

counterclockwise direction when viewed from the front of the machine. If spin is clockwise, the T1 and T2 motor wires connecting to terminal T1 and T2 on the variable frequency drive should be swapped. Remove power to the machine before opening service panels and swapping wires.

3 OPERATING INSTRUCTIONS

3.1 STARTING THE WASHER

3.1.1 Turn on power to the washer.

3.1.2 Load the laundry.

Place laundry into the cylinder and latch the door securely. Be sure laundry does not get caught between the door gasket and tub front when closing the door. Maximum load is the dry weight capacity listed in the specification sheet. Do not exceed the listed capacity weight.

NOTE: To begin closing the door, the handle must be in the horizontal position. After moving the door to the closed position, the handle must be turned down to the vertical position in order to latch the door for machine operation.

3.1.3 Select cycle temperature.

Select the appropriate cycle for the type of load being washed on the display UI screen.

3.1.4 Add washing chemicals.

Add low sudsing powdered detergent into the "DETERGENT" compartment of the automatic dispenser on the top or front of the washer.

If liquid wash products are used in the "DETERGENT" compartment, they must be added at the beginning of the wash cycle.

If desired, add fabric softener to the "FABRIC SOFTENER" compartment. Use the amount of fabric softener as recommended by the manufacturer.

If the machine is set for pre-wash, washing products can be added to the round opening of the dispenser or put in with the clothes when loading the washing machine.

If bleach is desired, DO NOT place into dispenser until the ADD BLEACH NOW message is displayed.

3.1.5 Start wash cycle.

Insert coins, tokens, debit card, or use the DexterPay mobile app to meet the displayed vend price. If vended with coins, tokens, or debit card, the display will count down the amount needed to meet the vend price. Once the vend price is met, the display will read

“PRESS START”. If the door is not closed and latched, the display will read “CLOSE DOOR”, and the control will wait until the door is latched to continue. Pressing the start button will begin the cycle. The display will show the remaining cycle time in minutes. The door will lock and remain locked until the end of the cycle.

3.2 END OF CYCLE

When the cycle is complete, a 3-second tone will sound, and the display will read “CYCLE COMPLETE” until the door is opened. The door can now be opened. Leave the clothes door open when the machine is not in use.

3.3 EMERGENCY STOP / SAFETY DOOR LOCK

This machine is equipped with a Safety Door Lock that locks the door closed from when the cycle is started until the cycle is complete. The door lock prevents opening the door for up to 3 minutes if the power is interrupted during the cycle.

The Emergency Stop button pauses the washer and allows the door to be opened during the cycle after the Safety Door Lock releases. When the Emergency Stop button is pressed, an alarm will sound, and the display will begin counting down and read “STOPPING IN 3”, “STOPPING IN 2”, “STOPPING IN 1”. If the button is released before 3 seconds elapse, the alarm will stop, and the cycle will continue normally. If the Emergency Stop is held down for 3 seconds, the display will count down, and the washer will begin stopping movement and water flow and begin draining water from inside the washer. Though the machine may stop wash movement quickly, it may take up to 3 minutes for the door to unlock. During that time, the alarm will continue to sound, and the display will read “STOPPING”. When the alarm stops, the door may be opened. The washer may be restarted by closing and latching the door and pressing the “PRESS HERE TO START” button. If the washer was stopped more than once before the final extract, the cycle will be cancelled. If the washer was stopped during final extract, the cycle will be ended. If the washer is stopped for more than 1 hour, the cycle will be terminated.

3.4 VARIABLE FREQUENCY DRIVE INDICATORS

There are three small colored LEDs located on the upper region of the Variable Frequency Drive (VFD). They are labeled as "READY", "RUN", and "FAULT" and can be used for troubleshooting. The definitions of the LEDs are listed in Table 1 below.



LED Status	Washer Condition
Steady Yellow	Tumbling
Blinking Yellow	Stop from Tumble
Steady Yellow	Ramp to Intermediate or Final Extract Spin
Steady Yellow	Spinning (Intermediate or Final)
Blinking Yellow	Stop from Spin (Intermediate or Final)
Steady Green	Idle Mode (No Cylinder Movement)
Steady Red	VFD fault
Blinking Red	VFD warning

Table 1: Variable Frequency Drive Indicators

4 MACHINE PROGRAMMING INSTRUCTIONS

The washer control can be programmed to prompt the user for alternate vend prices, change washer cycle times, temperatures, and many other options. This can be accomplished in two ways:

1. Manual programming utilizing the display UI screen.
2. USB download of a customizable User File. For instructions on using the USB download feature, please contact your local Dexter distributor or visit dexterlive.com.

4.1 MANUAL PROGRAMMING

The washer must be in idle mode for the manual programming menus to be accessed. Idle mode is when the washer is not actively running a wash cycle, and the vend price is displayed on the screen.

To enter the manual programming mode, the top of the washer must be unlocked and lifted slightly (it may be necessary to remove the screws for the soap box). The programming button is then pressed for 1 second. The control should display the manual programming home page.

See the figure below for the location of the programming button in relation to the USB port (The USB port is exposed when the washer top is lifted).

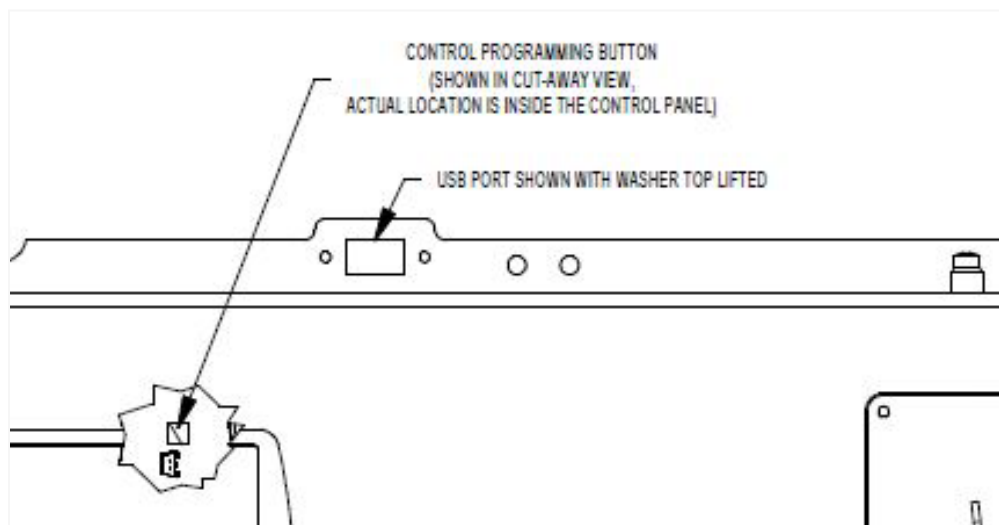

The table below shows the top-level menu. Choosing an option from the top-level menu will then display the next level of options (the sub menu).

System Info.
General
Profiles
Optional Cycles
Usage
Error Logs
Factory Reset

4.2 SYSTEM INFO.

The System Info. Menu displays important technical information for the control. No changes can be made on this screen. See below for detailed information on each sub menu option.

- 4.2.1 *"Model Id": The Model Id is the machine model type.*
- 4.2.2 *"SW Version": The SW Version is the current software version running on the control.*
- 4.2.3 *"Drive ID": The Drive ID is the Variable Frequency Drive's identification number.*
- 4.2.4 *"DexterLive ID": The DexterLive ID is the unique MAC address of the control. It allows the control to be recognized by network routers.*
- 4.2.5 *"IP Address": The IP Address is the identifier given to the control by a network system.*
- 4.2.6 *"Location Number": The Location Number is the DexterLive's location number the control is connected to.*
- 4.2.7 *"DexterPay Status": The DexterPay Status shows whether the control is connected to a DexterPay location.*

System Info.	
Model Id	Model Number
SW Version	XX.X.XXXX
Drive ID	XX.XX.XX
DexterLive ID	XX:XX:XX:XX:XX:XX
IP Address	XXX.XXX.XXX.XXX
Location Number	XXXXX

DexterPay Status	Enabled or Disabled
------------------	---------------------

4.3 GENERAL

The "General" Menu allows for the user to make various programming changes to change how the control operation affects the customer. See below for detailed information on each sub menu option.

- 4.3.1 *"Out of Service" – The control can be put into an Out-of-Service mode via manual programming. When the mode is "On", the control will display "Out of Service". The machine will not react to any vend input and will not operate when in this mode. The factory default is "Off".*
- 4.3.2 *"Language" – The control uses English for the default language of the customer prompts. Alternatively, the user can choose Spanish, French, Italian, Greek, Malay, Korean, Japanese, Simplified Chinese, or Traditional Chinese for the customer display prompts. However, all other prompts, such as Manual Programming, USB Programming and any Error Codes will still display in English.*
- 4.3.3 *"Currency" – The Currency setting displays which currency symbol is displayed as part of the revenue. This is a non-editable setting in manual programming but can be configured using DexterLive. The factory default is "\$".*
- 4.3.4 *"PassCode" – If the user programs the Passcode to any value other than 0000, the control will prompt the user to enter a Passcode (the programmed value) before manual programming can be accessed. The factory default is "0000" (no Passcode).*
 - a. Note that if the user forgets the Passcode, it can be reset to factory default (no Passcode), by performing a Factory Reset on the control. Please refer to the appropriate section of this manual to understand how to perform a Factory Reset.
 - b. The individual digits of the Passcode can be set by typing with the virtual number pad. Once all four correct digits are entered, the screen will advance to the Manual Programming menu.
- 4.3.5 *"End of Cycle Sounds" – If the user programs the End of Cycle Sounds to "Off", the control will not sound the enunciator at the end of a wash cycle. The factory default is "On".*
- 4.3.6 *"On Tap Sounds" – If the user programs the On Tap Sounds to "On", the control will sound every time the screen is tapped. The factory default is "Off".*
- 4.3.7 *"Screen Color" – If the user programs the Screen Color to "Dark", the screen will be in dark mode. The factory default is "Light".*
- 4.3.8 *"Display DexterPay ID" – If the user programs the Display DexterPay ID to "On", the DexterPay ID number for the machine will be shown on the*

screen. The factory default is "Off".

4.3.9 "Date/Time" – The control uses a Real Time Clock (RTC) to internally track the time and date. The RTC continues operation even if the control loses external power. The RTC is set for Central Standard Time. The time can either be represented in 12 or 24 hour time. However, if a problem occurs and the RTC time is not accurate, it can be reset to the current time using this option when the control detects an outside network connection (via Ethernet port). The Time Zone change selected will shift the Real Time Clock (RTC) time stored in the control to the appropriate choice.

4.3.10 "View Non-Critical Errors" – If the user programs the View Non-Critical Errors to "Off", the control will not display the non-critical errors (non-cycle ending errors) if they occur during the cycle. This includes "Slow Fill Error", "Slow Drain Error", and "Water Leak Detection" codes. These errors will still be logged in the Error Log. The factory default is "On".

4.3.11 "Left Coin Value" – The user can program the value for the left coin acceptor input. The factory default is 0.25.

4.3.12 "Right Coin Value" – The user can program the value for the right coin acceptor input. The factory default is 1.00.

General		
Out of Service	On or Off	
Language	English, Spanish, French, Italian, Greek, Malay, Korean, Japanese, Simplified Chinese, Traditional Chinese	
Currency	Select Currency	
PassCode	0000 through 9999	
End of Cycle Sounds	On or Off	
On Tap Sounds	On or Off	
Screen Color	Light or Dark	
Display DexterPay ID	On or Off	
Date/Time	Time Zone	PST/MST/CST/EST/etc.
	Time Format	12hr or 24hr
	Time	
	Date	
View Non-Critical Errors	On or Off	
Left Coin Value	0.01 through 999.99	
Right Coin Value	0.01 through 999.99	

4.4 PROFILES

The Profiles Menu allows the user to configure the pricing and cycle settings for the machine. See below for detailed information on each sub menu option.

4.4.1 *The Pricing section allows the user to set each wash cycle's Base Price and Adder Price.*

The Base Price is the price of a standard cycle without factoring in any additional pricing included in the cycle, such as Temperature Adders or Plus Cycle Adders. The factory default for the Normal cycle type matches the machine model number (e.g. T-950 = 9.50). Heavy is +0.50 than Normal; Light is -0.25 than Normal; Delicate is -0.50 than Normal.

The adder prices can be set for the Plus Cycle Options: Pre-Wash, Extend Wash, Extra Rinse, and Extend Spin. When these Adder Options are enabled, they can be purchased up front before the cycle begins or during a cycle. If the customer does not meet the vend price of the Plus Cycle Option, and the time for purchasing the option has passed, the additional time will not be added to the cycle. The factory default for each adder is 0.00.

The user can also program the prices for the Drum Clean and End of Cycle Rinse & Spin cycles and the Warm Adder and Hot Adder temperatures. The factory default for these prices is 0.00.

Pricing		
Delicate	Base Price	0.00 through 999.99
	Pre-Wash Adder	0.00 through 999.99
	Extend Wash Adder	0.00 through 999.99
	Extra Rinse Adder	0.00 through 999.99
	Extend Spin Adder	0.00 through 999.99
Light	Base Price	0.00 through 999.99
	Pre-Wash Adder	0.00 through 999.99
	Extend Wash Adder	0.00 through 999.99
	Extra Rinse Adder	0.00 through 999.99
	Extend Spin Adder	0.00 through 999.99
Normal	Base Price	0.00 through 999.99
	Pre-Wash Adder	0.00 through 999.99
	Extend Wash Adder	0.00 through 999.99
	Extra Rinse Adder	0.00 through 999.99
	Extend Spin Adder	0.00 through 999.99
Heavy	Base Price	0.00 through 999.99
	Pre-Wash Adder	0.00 through 999.99
	Extend Wash Adder	0.00 through 999.99
	Extra Rinse Adder	0.00 through 999.99
	Extend Spin Adder	0.00 through 999.99
Drum Clean	Price	0.00 through 999.99
End of Cycle Rinse & Spin	Price	0.00 through 999.99
Water Temp Adders	Warm Adder Price	0.00 through 999.99
	Hot Adder Price	0.00 through 999.99

4.4.2 The Cycles section allows the user to configure each cycle's settings.

The user can choose a default cycle to have automatically chosen for new cycle purchases. This is configured with the Default Cycle setting. The factory default is "NORMAL". The control has four available cycles: Delicate, Light, Normal, and Heavy. Each of the Cycle Types, with the exception of the Normal cycle, can be enabled or disabled. The factory default is "On" for all of the cycle types. The Agitation Speed of each cycle controls the tumble speed. It is configurable for only the Light cycle type. The factory default is "DELICATE" for the Delicate and Light Cycle Types and "NORMAL" for the Normal and Heavy Cycle Types.

The default cycle consists of a Wash, Rinse, Final Rinse, and Final Spin. Additional stages can be added to a cycle when enabled.

With the Pre-Wash feature active, the customer will have the option to purchase an additional bath before the standard Wash bath. Users can control how Pre-Wash is made available to customers using the Availability setting which has a default setting of "OFF".

1. OFF – Adder is disabled

2. OPTION_ON – Adder is available but defaulted to the “On” state. Customers must de-select the adder from their purchase
3. OPTION_OFF – Adder is available but defaulted to the “Off” state. Customers must select the adder to add the adder to their purchase.
4. CYCLE – Adder is included in every cycle. Customers do not have the option to include the adder in their purchase.

The total time for the Pre-Wash stage can be set with the Agitation Time setting. The water temperature and level can also be configured and have default settings of “COLD” and “LOW”.

The Wash stage includes the Agitation time, Water Level, and Intermediate spin time settings for the standard Wash bath. Water temperature for the “Wash” stage is chosen by the customer before the start of the cycle.

Extend Wash allows the user to add additional time to the standard Wash bath. This feature will have the same availability settings as described above in the Pre-Wash section. Extend Wash has a default setting of “OFF”.

Extra Rinse allows the user to add an additional rinse stage to the cycle. This feature will have the same availability settings as described above in the Pre-Wash section. Extra Rinse has a default setting of “OFF”.

Extend Spin allows the user to add additional time to the Final Extract Spin. This feature will have the same availability settings as described above in the Pre-Wash section. Extend Spin has a default setting of “OFF”.

“Drum Clean” will begin a separate shortened 3-minute cycle that is not part of the normal wash. There will not be a spin for this cycle. Hot water fill will be used, and the detergent and softener compartments will both be flushed. This cycle can be enabled or disabled. The default setting is “OFF”.

The End of Cycle Rinse & Spin cycle allows the user to purchase an additional Final Rinse and Spin after the door is opened at the end of the normal wash cycle. This cycle can be enabled or disabled. The default setting is “OFF”.

Cycles				
Default Cycle Selection	Delicate, Light, Normal, or Heavy			
Delicate/Light/Normal/Heavy	Cycle Availability	On or Off (Not configurable for Normal)		
	Agitation Speed	<i>Delicate</i> = Delicate, <i>Light</i> = Delicate or Normal, <i>Normal</i> = Normal, <i>Heavy</i> = Normal		
	Stages	Pre-Wash	Availability	Off, Cycle, Option_On, or Option_Off
			Agitation Time	1 to 15 minutes
		Water	Temperature	Cold, Warm, or Hot
			Level	Low (Normal/Heavy = Low or High)
Wash	Agitation	3 to 15 minutes		

			Time			
			Water	Level	Low or High	
			Spin	Duration	0 to 10 minutes	
			Extend Wash	Availability	Off, Cycle, Option_On, or Option_Off	
				Duration	1 to 10 minutes	
			Rinse	Agitation Time	0 to 15 minutes	
				Water	Temperature	Cold or Warm
					Level	Low or High
			Extra Rinse	Spin	Duration	0 to 10 minutes
				Availability	Off, Cycle, Option_On, or Option_Off	
				Agitation Time	1 to 15 minutes	
				Water	Temperature	Cold or Warm
			Level		Low (Normal = Low or High)	
			Final Rinse	Spin	Duration	0 to 10 minutes
				Agitation Time	3 to 15 minutes	
					Water	Temperature
				Level		Low or High
				Spin	Duration	1 to 10 minutes
					Speed	60G, 80G, 100G, 120G, 140G, 160G, 180G, or 200G
			Extend Spin	Availability	Off, Cycle, Option_On, or Option_Off	
Duration	1 to 10 minutes					
Drum Clean	Agitation	Agitation Speed	Normal			
	Availability	Off or Option_Off				
End of Cycle Rinse & Spin	Water	Temperature	Cold or Warm			
		Level	Low or High			
	Agitation	Duration	3 to 15 minutes			
		Agitation Speed	Delicate or Normal			
	Spin	Duration	1 to 10 minutes			
		Speed	60G, 80G, 100G, 120G, 140G, 160G, 180G, or 200G			
Availability	Off or End_Of_Cycle					

4.4.3 "Temperature": This option allows the user to choose which water temperature will be chosen automatically by default. The customer will have the option to choose a different water temperature for the wash bath. The factory default is "WARM".

4.4.4 "Water Levels": This option allows the user to choose the specific water level value for Low and High water levels. There are 10 level values

available. The "Low" water level has options of 1 through 5 and "High" water level has options of 6 through 10. The factory default for "Low" level is "2 (Eco)" and "10 (Classic)" for "High" level.

4.4.5 "Delay Fill": This option is meant to be used in applications where the amount of available water pressure is limited. In these cases, the washer may not be able to fill the tub in sufficient time to allow for effective washing performance.

When the "Delay Fill" option is "On", the water valves shall be turned on, the washer shall agitate, but the cycle time shall be paused. The washer shall continue in this statue until the proper water level is reached. Once the proper water level is reached, the cycle shall continue. A single selection of "On" or "Off" shall apply to all baths in the cycle. The factory default setting is "Off".

4.4.6 "Delay Spin": This option is meant to be used in applications where the amount of drain capacity is limited. In these cases, the washer cannot empty the tub in sufficient time to allow for a spin cycle to occur.

When a time value is programmed for the "Delay Spin" option, the end of each bath will be extended by the selected time. Therefore, extra time will be allowed for the drain valve to be open and compensate for slow drain capacity. The factory default is "Off".

4.4.7 "Add Bleach Prompt": This option allows the user to choose whether the "ADD BLEACH NOW" message is displayed during the cycle. If the option is "On", the message is displayed on the UI at 150 seconds after the start of the Wash bath; if the water level isn't met by this point, the UI will display the "ADD BLEACH NOW" message once the water level is met. This prompt will alternate with the "WASH IN PROCESS" message every 1 second for 150 seconds or until the end of the Wash bath. This is the only time during the cycle that this prompt is on. If the programmed water level is no longer met, the control will stop the display of "ADD BLEACH NOW". The alternating display of "ADD BLEACH NOW" and "WASH IN PROCESS" won't resume until the Wash bath's programmed water level is met again.

The control should report to DexterLive it is prompting for bleach when set to "On" so that customers can be notified in DexterPay. When set to "Off", no "ADD BLEACH NOW" prompt will be displayed to the customer, and the control will not indicate to DexterLive that it is prompting for bleach. The factory default is "On".

Temperature	Default Temperature	Cold, Warm, or Hot
Water Levels	High Setting	6 to 10
	Low Setting	1 to 5
Delay Fill	On or Off	
Delay Spin	0:00 to 2:30	
Add Bleach Prompt	On or Off	

4.5 OPTIONAL CYCLES

This option allows the user to select the different test and short-cycle options. See below for detailed information on each sub menu option.

- 4.5.1 *"Final Rinse and Spin" will begin only the Final Rinse Bath and Final Spin portions of the cycle without the displayed vend price being met. The configured temperature, cycle times, and spin speed for the Final Rinse Bath and Final Spin settings will be used when this option is selected. Error Codes should all function normally during this test.*
- 4.5.2 *"Drum Clean" will begin a shortened cycle without the displayed vend price being met. The cycle will be a 3-minute cycle (no spin). Hot water fill will be used, and the detergent and softener compartments will both be flushed. Error Codes should all function normally during this cycle.*
- 4.5.3 *"Quick Cycle" will begin a shortened wash cycle without the displayed vend price being met. The purpose of this shortened cycle is to test all major components for proper operation.*
- Error Codes should all function normally during this test. The display will show customer prompts in a similar way to a normal wash cycle. Exceptions to this are that the "ADD BLEACH NOW" prompt will not occur because of reduced cycle time. Final Extract speed is specific to the customer's programming.*
- 4.5.4 *"Manufacturing Test Cycle" will begin a test cycle without the displayed vend price being met. Only pulses from the left coin input should be accepted to decrement the vend price. The cycle will be a 14-minute cycle (with final spin). Hot water fill will be used, and the detergent and softener compartments will both be flushed. Error Codes should all function normally during this cycle.*

Optional Cycles	
Final Rinse & Spin	Run Cycle
Drum Clean	Run Cycle
Quick Cycle	Run Cycle
Manufacturing Test Cycle	Run Cycle

4.6 USAGE

The Usage menu allows for the user to track data about machine usage. See below for detailed information on each sub menu option.

- 4.6.1 *"Coin Vault": The Coin Vault field contains all the coin information for the machine with the following fields:*
- "Revenue Since Last Reset": The revenue since last reset field shows the accumulated revenue amount since the control had the coin vault last reset.*

- b. "Left Amount": The left amount field shows the total revenue amount from the left coin input since the control had the coin vault last reset.
- c. "Right Amount": The right amount field shows the total revenue amount from the right coin input since the control had the coin vault last reset.
- d. "Left Input": The left input amount shows the accumulation of coin pulses that were sent to the control over the left coin input. Note that this is a count of coin pulses, not an accumulated report of vend value.
- e. "Right Input": The right input amount shows the accumulation of coin pulses that were sent to the control over the right coin input. Note that this is a count of coin pulses, not an accumulated report of vend value.
- f. "Display Message": If the user programs the Display Message to "On", the display will show a screen that indicates the coin box has been removed. This screen will be displayed for 30 seconds. When the coin box is reinserted into the coin vault, the UI will prompt the user to reset the coin count. This prompt will also display for 30 seconds. If set to "Off", the "Coin Box Removed" screen will not be displayed when the coin box is removed. The user can still reset the coin box via Manual Programming. The factory default is "On".
- g. "Reset Type": If the user programs the Reset Type to "MANUAL", the user can reset the coin audit values manually via Manual Programming or when the Coin Box message is displayed. If the user programs the Reset Type to "AUTO", the coin audit values will automatically be reset when the control detects the coin box has been removed and does not require user input to reset the coin audit values. The factory default is "MANUAL".
- h. "Reset Options": This option controls which options get reset when coin vault resets occur. If the user programs the Reset Options to "LEFT", only the Left Input and Left Amount values will be reset. If the user programs "RIGHT", only the Right Input and Right Amount values will be reset. If the user programs "BOTH", both Left and Right Input and Amount values will be reset. The factory default is "BOTH".
- i. "Reset History": Each coin vault reset will be stored in the control with a time and date stamp. The purpose of this option is only to observe the history of these reset occurrences (no changes can be made). The time is based off the Real Time Clock setting.

4.6.2 "Cycle Count": The controller will store a count of the number of cycles that have been initiated by way of a completed vend price and "start" interaction with the customer. This will be stored as a number up to 5 places (XXXXX). This value will reset to 00000 after 99999.

4.6.3 "Motor Hours": The controller shall track the number of hours the washer motor has been in operation. This information is displayed as a single value on a UI screen accessed via Manual Programming. This will be in hours to 5 places (XXXXX). This value will reset to 00000 after 99999.

In many cases, it will match the cycle hours of the machine. However, separate fields are provided in the event that a motor is replaced on a machine.

4.6.4 "Cycle Hours": The controller shall store the time that a wash cycle has been in use (hours). This information is displayed as a single value on a UI screen accessed via Manual Programming. This will be equivalent, in many cases, to the motor hours, but if a user changes a motor, the motor hours may be reset separately, and the Cycle Hours value would continue to accumulate hours. This will be in hours to 5 places (XXXXX). This value will reset to 00000 after 99999. The value displayed will round down to the nearest hour.

Usage		
Coin Vault	Revenue Since Last Reset	Amount
	Left Amount	Amount
	Right Amount	Amount
	Left Input	0000 through 9999
	Right Input	0000 through 9999
	Display Message	On or Off
	Reset Type	Manual or Auto
	Reset Options	Left, Right, or Both
	Reset History	Reset #1
	Reset ...	
	RESET button	
Cycle Count	0000 through 9999	
Motor Hours	0000 through 9999	Set Motor Hours
Cycle Hours	0000 through 9999	Set Cycle Hours

4.7 ERROR LOGS

The last three hundred error codes will be stored in the control with a time and date stamp. The purpose of this option is only to observe the history of these code occurrences (no changes can be made). Factory resets on the control do not clear the error code logs.

The time is based off the Real Time Clock. As additional error codes occur, the oldest of the three hundred logged codes is cleared from memory.

Error Logs
Error #1
Error ...

4.8 FACTORY RESET

The Factory Reset will change all adjustable parameters in the control back to factory default settings. This will create the same reset function as using the Graphics Board hardware buttons. An exception to this is the Error Logs option. After the Factory Reset, the First Time Start-Up screens will be displayed, and the user will have the options to

make all changes associated with these screens.

4.9 COIN WASHER DEFAULT CYCLE

The following tables show the complete details for the coin washer default cycle for all four Cycle Types.

Delicate/Light				
Bath	Bath Cycle Time (min.)	Water Temp.	Delay Fill	Spin Time (min.)
Prewash	0	Cold	Off	0
Wash	6	Warm	Off	0
Extend Wash	0	n/a	n/a	n/a
Rinse	4	Cold	Off	0
Final Rinse	4	Cold	Off	n/a
Extra Rinse Spin	n/a	n/a	n/a	0
Extra Rinse Bath	0	Cold	Off	n/a
Final Extract Spin	n/a	n/a	n/a	4

Normal				
Bath	Bath Cycle Time (min.)	Water Temp.	Delay Fill	Spin Time (min.)
Prewash	0	Cold	Off	0
Wash	9	Warm	Off	0
Extend Wash	0	n/a	n/a	n/a
Rinse	4	Cold	Off	1
Final Rinse	5	Cold	Off	n/a
Extra Rinse Spin	n/a	n/a	n/a	0
Extra Rinse Bath	0	Cold	Off	n/a
Final Extract Spin	n/a	n/a	n/a	6

Heavy				
Bath	Bath Cycle Time (min.)	Water Temp.	Delay Fill	Spin Time (min.)
Prewash	0	Cold	Off	0
Wash	10	Warm	Off	0
Extend Wash	0	n/a	n/a	n/a
Rinse	5	Cold	Off	1
Final Rinse	5	Cold	Off	n/a
Extra Rinse Spin	n/a	n/a	n/a	0
Extra Rinse Bath	0	Cold	Off	n/a
Final Extract Spin	n/a	n/a	n/a	6

4.10 WASHERS WITHOUT COIN ACCEPTORS

If you purchased a washer without a coin acceptor and are installing a payment device of your choice, refer to the washer wiring diagram for proper connection. You may also need to contact the payment device supplier for additional information.

4.11 WATER LEVEL ADJUSTMENT

The water level of each bath can be set to Low or High level. The Low and High level is programmed to an associated value. There are ten total levels, with five levels being available for Low level and five levels being available for High level. The following shows the equivalent values to previous models with Low and High water levels:

Low

- 1
- 2 (Eco Low)
- 3
- 4
- 5

High

- 6
- 7
- 8
- 9
- 10 (Classic Low)

The dip switches on the water pressure sensor board DO NOT adjust water levels on this product.

5 DISPLAYED WASHER MESSAGES

The washer control reacts to various abnormal conditions by displaying an Error message. These messages usually contain the "Error" text, and then a general description of the message. Below is a listing of Error messages separated by each potential displayed message in bold face. Each is followed by:

- Condition that creates the displayed message on the control
- Action that the control takes responding to the condition
- Exit is the method the user (or the control) should use to bring the machine back to normal operation.

The actual displayed message on the control may contain the general description listed below and additional details (such as number or additional text). However, the condition, action or exit qualities of the error message should be the same for all variations.

OPERATION IN PROGRESS	
Condition	This error occurs when the user is attempting to start a machine operation while another operation is ending.
Action	When detected, the control does not respond to user input. There is no delay in the action once the criteria are met. The control will finish the current operation while displaying "OPERATION IN PROGRESS". Once the operation is complete, the error will no longer be displayed, and the control will respond to user input normally.
Exit	The error will be reset automatically once the current operation is complete.
POWER LOSS	
Condition	This error occurs when the Main Control Board detects a total loss of 24VAC power (usually accompanied by loss of power to the complete machine).
Action	When detected, the control turns off the motor and all other outputs. There is no delay in the action once the criteria are met.
Exit	The machine will not start, and the Error Code will continue to be displayed until the condition is no longer present. Once the condition is removed, the machine still will not start, and the Error Code will continue to be displayed for 10 seconds. After 10 seconds, the Error code should automatically reset and the cycle should be ready to re-start or the control should be in Idle mode (depending on the time period of the power loss).
BROWN OUT	
Condition	This error occurs when the Main Control Board detects less than 21VAC at the 24VAC input.
Action	When detected, the control turns off the motor and all other outputs. There is no delay in the action once the criteria are met.
Exit	The machine will not start, and the Error Code will continue to be displayed until the condition is no longer present. Once the condition is removed, the machine still will not start, and the Error Code will continue to be displayed for 10 seconds. After 10 seconds, the Error code should automatically reset and the cycle should be ready to re-start or the control should be in Idle mode (depending on the time period of the power loss).

CONTROL FIRMWARE ERROR	
Condition	This error occurs when the Main Control Board cannot command the input and outputs of the control system as required by the cycle programming.
Action	When detected, the control turns off the motor and all other outputs. There is no delay in the action once the criteria are met.
Exit	The machine will not start, and the Error Code will continue to be displayed until power is cycled to the machine, or the control is Reset to return it to Idle Mode.

DOOR SHUT, NOT LOCKED	
Condition	This error occurs after 3 attempts of starting the cycle when the Door Locked signal is not received within 1 second. It will also occur at any other point in the Washer cycle if the Door Lock signal is lost while a Wash cycle is in-progress.
Action	When detected, the control turns off the motor and all other outputs. There is no delay in the action once the criteria are met.
Exit	The machine will not start, and the Error Code will continue to be displayed until power is cycled to the machine, or the control is Reset to return it to Idle Mode.

SLOW SPIN	
Condition	This error occurs when the motor does not reach a target frequency while accelerating, within a specified time.
Action	When detected, the control turns off the motor and machine motion stops.
Exit	The machine will not start, and the Error Code will continue to be displayed until power is cycled to the machine, or the control is Reset to return it to Idle Mode.

SPIN TIME	
Condition	This error occurs when the motor does not reach a target frequency while decelerating, within a specified time.
Action	When detected, the control turns off the motor and machine motion stops.
Exit	The machine will not start, and the Error Code will continue to be displayed until power is cycled to the machine, or the control is Reset to return it to Idle Mode.

SLOW FILL	
Condition	This error occurs when the programmed water level is not reached within 7 minutes.
Action	When detected at 7 minutes into the stage, the control will display the "SLOW FILL ERROR" prompt, alternating with the normal Cycle Progress screen at a rate of 5 seconds on, 5 seconds off. Otherwise the cycle will continue normally.
Exit	The Error Code will continue to be displayed until the in-progress cycle is stopped and the control is returned to Idle Mode. It will then reset automatically and the next washer cycle can be started normally.

WATER LEAK DETECTED	
Condition	This error occurs when the programmed water level has been met and the water valve continue to actuate during the same washer stage
Action	When detected, the control will display the "WATER LEAK DETECTED" prompt, alternating with the normal Cycle Progress screen at a rate of 5 seconds on, 5 seconds off. Otherwise the cycle will continue normally.

Exit	The Error Code will continue to be displayed until the in-progress cycle is stopped and the control is returned to Idle Mode. It will then reset automatically and the next washer cycle can be started normally.
WATER PRESSURE SENSOR NOT DETECTED	
Condition	This error occurs when the control doesn't detect the water pressure sensor upon bootup.
Action	When detected, the control turns off the motor and all other outputs. There is no delay in the action once the criteria are met. This check is only performed upon control bootup.
Exit	The machine will not start, and the Error Code will continue to be displayed until the condition is no longer present. Once the condition is removed, the machine still will not start, and the Error Code will continue to be displayed until power is cycled to the machine, or the control is Reset to return it to Idle Mode.
SLOW DRAIN	
Condition	This error occurs when an empty water level is not reached within 5 minutes.
Action	When water pressure is detected at the beginning of the drain operation, the prompt "SLOW DRAIN ERROR" is displayed, alternating with the normal Cycle Progress screen at a rate of 5 seconds on, 5 seconds off. The washing (agitating) continues for an additional 5 minutes. If water pressure is still present after 5 minutes, the Spin portion of the stage is skipped. Also, if water pressure is detected during a Spin portion of a stage, the control will command deceleration to occur. Agitation will then be used to continue during the remaining stage time.
Exit	The Error Code will continue to be displayed until the in-progress cycle is stopped and the control is returned to Idle Mode. It will then reset automatically and the next washer cycle can be started normally.

GRAPHICS SOFTWARE ERROR	
Condition	This error occurs when the Graphics Board cannot command the Main Control board as required by the cycle programming.
Action	When detected, the control turns off the motor and all other outputs. There is no delay in the action once the criteria are met.
Exit	The machine will not start, and the Error Code will continue to be displayed until power is cycled to the machine, or the control is Reset to return it to Idle Mode.
MODEL JUMPER MISSING	
Condition	This error occurs when there is no connection to Ground (Pin 8) on the Model Jumper Header.
Action	When detected, the control turns off the motor and all other outputs. There is no delay in the action once the criteria are met. The machine control checks for this condition when power is cycled and before starting every machine cycle.
Exit	The machine will not start, and the Error Code will continue to be displayed until the condition is no longer present. Once the condition is removed, the machine still will not start, and the Error Code will continue to be displayed until power is cycled to the machine, or the control is Reset to return it to Idle Mode.
MODEL JUMPER CHANGED	
Condition	This error occurs when the jumper connections to Ground (Pin 8) on the Model Jumper Header have changed since the last control check.
Action	When detected, the control turns off the motor and all other outputs. There is no delay in the action once the criteria are met. The machine control checks for this

	condition when power is cycled and before starting every machine cycle.
	The machine will not start, and the Error Code will continue to be displayed until the condition is no longer present. Once the condition is removed, the machine still will not start, and the Error Code will continue to be displayed until power is cycled to the machine, or the control is Reset to return it to Idle Mode.
MODEL JUMPER DRIVE SIZE MISMATCH	
Condition	This error occurs when the jumper connections to Ground (Pin 8) on the Model Jumper Header do not match the VFD size code.
Action	When detected, the control turns off the motor and all other outputs. There is no delay in the action once the criteria are met. The machine control checks for this condition when power is cycled.
Exit	The machine will not start, and the Error Code will continue to be displayed until the condition is no longer present. Once the condition is removed, the machine still will not start, and the Error Code will continue to be displayed until power is cycled to the machine, or the control is Reset to return it to Idle Mode.
MODEL JUMPER/ DRIVE PARAMETER	
Condition	This error occurs when the jumper connections to Ground (Pin 8) on the Model Jumper Header do not match the VFD parameters being used.
Action	When detected, the control turns off the motor and all other outputs. There is no delay in the action once the criteria are met. The machine control checks for this condition when power is cycled.
Exit	The machine will not start, and the Error Code will continue to be displayed until the condition is no longer present. Once the condition is removed, the machine still will not start, and the Error Code will continue to be displayed until power is cycled to the machine, or the control is Reset to return it to Idle Mode.
NON-DEXTER DRIVE	
Condition	This error occurs when a non-Dexter VFD is installed in the machine.
Action	When detected, the control turns off the motor and all other outputs. There is no delay in the action once the criteria are met. The machine control checks for this condition when power is cycled and before starting every machine cycle.
Exit	The machine will not start, and the Error Code will continue to be displayed until the condition is no longer present. Once the condition is removed, the machine still will not start, and the Error Code will continue to be displayed until power is cycled to the machine, or the control is Reset to return it to Idle Mode.
DRIVE OVERCURRENT	
Condition	This error occurs when the control receives a message that the drive has experienced an over current condition.
Action	When detected, the control turns off the motor and all other outputs. There is no delay in the action once the criteria are met.
Exit	The machine will not start, and the Error Code will continue to be displayed until the condition is no longer present. Once the condition is removed, the machine still will not start, and the Error Code will continue to be displayed until power is cycled to the machine, or the control is Reset to return it to Idle Mode.
DRIVE OVERVOLTAGE	
Condition	This error occurs when the control receives a message that the drive has experienced an over voltage condition.

Action	When detected, the control turns off the motor and all other outputs. There is no delay in the action once the criteria are met.
Exit	The machine will not start, and the Error Code will continue to be displayed until the condition is no longer present. Once the condition is removed, the machine still will not start, and the Error Code will continue to be displayed until power is cycled to the machine, or the control is Reset to return it to Idle Mode.
DRIVE OVERHEAT	
Condition	This error occurs when the control receives a message that the drive has experienced an overheat condition.
Action	When detected, the control turns off the motor and all other outputs. There is no delay in the action once the criteria are met.
Exit	The machine will not start, and the Error Code will continue to be displayed until the condition is no longer present. Once the condition is removed, the machine still will not start, and the Error Code will continue to be displayed until power is cycled to the machine, or the control is Reset to return it to Idle Mode.
DRIVE OVERLOAD	
Condition	This error occurs when the control receives a message that the drive has experienced an overload condition.
Action	When detected, the control turns off the motor and all other outputs. There is no delay in the action once the criteria are met.
Exit	The machine will not start, and the Error Code will continue to be displayed until the condition is no longer present. Once the condition is removed, the machine still will not start, and the Error Code will continue to be displayed until power is cycled to the machine, or the control is Reset to return it to Idle Mode.
DRIVE GROUND FAULT	
Condition	This error occurs when the control receives a message that the drive has experienced a ground fault condition.
Action	When detected, the control turns off the motor and all other outputs. There is no delay in the action once the criteria are met.
Exit	The machine will not start, and the Error Code will continue to be displayed until the condition is no longer present. Once the condition is removed, the machine still will not start, and the Error Code will continue to be displayed until power is cycled to the machine, or the control is Reset to return it to Idle Mode.
DRIVE LOW VOLTAGE	
Condition	This error occurs when the control receives a message that the drive has experienced a low voltage condition.
Action	When detected, the control turns off the motor and all other outputs. There is no delay in the action once the criteria are met.
Exit	The machine will not start, and the Error Code will continue to be displayed until the condition is no longer present. Once the condition is removed, the machine still will not start, and the Error Code will continue to be displayed until power is cycled to the machine, or the control is Reset to return it to Idle Mode.
DRIVE INTERNAL	
Condition	This error occurs when the control receives a message that the drive has experienced an internal error.
Action	When detected, the control turns off the motor and all other outputs. There is no

	delay in the action once the criteria are met.
Exit	The machine will not start, and the Error Code will continue to be displayed until the condition is no longer present. Once the condition is removed, the machine still will not start, and the Error Code will continue to be displayed until power is cycled to the machine, or the control is Reset to return it to Idle Mode.
DRIVE EXCEPTION	
Condition	This error occurs when the control receives a message that the drive has logged an exception code.
Action	When detected, the control turns off the motor and all other outputs. There is no delay in the action once the criteria are met.
Exit	The machine will not start, and the Error Code will continue to be displayed until the condition is no longer present. Once the condition is removed, the machine still will not start, and the Error Code will continue to be displayed until power is cycled to the machine, or the control is Reset to return it to Idle Mode.
DRIVE COMMUNICATION	
Condition	This error occurs the control cannot communicate with the VFD.
Action	When detected, the control turns off the motor and all other outputs. There is no delay in the action once the criteria are met.
Exit	The machine will not start, and the Error Code will continue to be displayed until the condition is no longer present. Once the condition is removed, the machine still will not start, and the Error Code will continue to be displayed until power is cycled to the machine, or the control is Reset to return it to Idle Mode.
DRIVE ENABLE	
Condition	This error occurs when the control sees a message that the VFD Enable circuit is not closed.
Action	When detected, the control turns off the motor and all other outputs. There is no delay in the action once the criteria are met.
Exit	The machine will not start, and the Error Code will continue to be displayed until the condition is no longer present. Once the condition is removed, the machine still will not start, and the Error Code will continue to be displayed until power is cycled to the machine, or the control is Reset to return it to Idle Mode.
OUT OF SERVICE	
Condition	This error occurs when the user has designated that the machine control should be made inoperable.
Action	When detected, the control turns off the motor and all other outputs. There is no delay in the action once the criteria are met.
Exit	The machine will not start, and the Error Code will continue to be displayed the user changes the Out of Service state.
CYCLE UNEXPECTEDLY STOPPED	
Condition	This error occurs when the information received from the Main Control board arrives in an unexpected order.
Action	When detected, the control turns off the motor and all other outputs. There is no delay in the action once the criteria are met.
Exit	The machine will not start, and the Error Code will continue to be displayed until power is cycled to the machine, or the control is Reset to return it to Idle Mode.

Max Pause Time Exceeded	
Condition	This error occurs when a power loss or a brown out event causes an in-progress cycle to stop. If the cycle is not resumed after 1 hour, this error will be thrown.
Action	When detected, the control turns off the motor and all other outputs. There is no delay in the action once the criteria are met.
Exit	No action required. Error will be displayed for 5 seconds and then return to Idle screen.
PRESSURE OUT OF RANGE LOW	
Condition	This error occurs when the averaged analog readings from the Water Pressure Sensor is below 150mVDC for 3 consecutive seconds.
Action	When detected, the control turns off the motor and all other outputs and the door will remain locked. There is no delay in the action once the criteria are met.
Exit	The machine will not start, and the Error Code will continue to be displayed until power is cycled to the machine or the control is Reset to return it to Idle Mode.
PRESSURE OUT OF RANGE HIGH	
Condition	This error occurs when the averaged analog readings from the Water Pressure Sensor is above 3VDC for 3 consecutive seconds.
Action	When detected, the control turns off the motor and all other outputs and the door will remain locked. There is no delay in the action once the criteria are met.
Exit	The machine will not start, and the Error Code will continue to be displayed until power is cycled to the machine or the control is Reset to return it to Idle Mode.

Note: Whenever power is turned off to the washer, it **must** remain off for one minute. The washer will not operate properly if this is not done.

6 TROUBLESHOOTING

CAUTION: Label all wires prior to disconnection when servicing controls. Wiring errors can cause improper and dangerous operation. Verify proper operation after servicing.

ATTENTION: Lors des opérations d'entretien des commandes, étiqueter tous les fils avant de les déconnecter. Toute erreur de câblage peut être une source de danger et de panne.

If any of the following symptoms occur on this washer, check the suggested remedies listed below. If all probable causes have been eliminated and the symptom still exists, contact your local Dexter agent for further troubleshooting assistance. See contact information at the end of this manual. Parts & Service Manuals from Dexter are also available for further troubleshooting assistance.

Symptom	Probable Cause	Suggested Remedy
Machine does not start	Power supply	Check these areas: Circuit breakers, Voltage, Power leads, Power connections. Is front display LED showing a dollar amount?
	Door Switch	Check for continuity through door switch when door is closed. If no continuity, adjust or replace door switch.
	Control breaker or Fuse	60 Hz: Check 2.0 amp breaker or fuse (50 Hz: 7 amp) for continuity. If no continuity, replace breaker or fuse.
	Control Transformer	Check voltage output from control transformer for 120VAC and 24VAC (60 Hz) or 24VAC (50 Hz). If voltage is incorrect, replace transformer.
	Coin Acceptor	Check coin acceptor switch for any type of blockage or damage. Clean, adjust or replace the acceptor.
	Check PCB board	Check all wire connections for loose contacts.
	Check wiring between PCB	Check data cable. This is the cable with the phone type connectors on the main PCB control and the VFD. With the power removed, unplug and check for damage, replug and retry washer.
	Check Relay PCB	Check all wire connections for sure contact.
	Check Door Locking Motor	Check that 120 VAC (60 Hz) or 24 VAC (50 Hz) power is at motor after start button is selected.
Machine will not accept and count coins	Coin Acceptor	Check coin acceptor switch for any type of blockage or damage. Clean, adjust or replace the acceptor.
	Power Supply	Check these areas: Circuit breakers, Voltage, Power leads, Power connection
	Door Closed Safety Switch	Check door closed switch at door hinge for proper operation.
	Door Handle Closed Switch	Check single door closed switch at left side of door handle to close when handle is vertical.
	Control Breaker or fuse	Check breaker or fuse for continuity. If no continuity, replace breaker or fuse. For 60 Hz, check 2.0 amp breaker or fuse. (For 50 Hz, all use 7 amp)
	Graphics Board	Replace

Door does not lock	Check display for fault code	Does "DOOR SHUT NOT LOCKED " show on the front of display? If yes, follow tests described in fault code section.
	Door locking motor	Check to ensure that motor is receiving 120 VAC (60 Hz) or 24 VAC (50 Hz) from main relay PCB. If it is, replace motor.
	Door Switch	Check for continuity through door latch switch when door closed. If no continuity, adjust or replace door switch.
Door will not open	Thermoactuator	Check to see if thermoactuator and its mechanism are stuck or binding and not allowing the door lock motor to open. Check to be sure that the locking thermoactuator is not receiving 24 VAC (50 Hz and 60 Hz) during the last 1 1/2 minutes of the cycle. Also, check to see that the unlocking thermoactuator is receiving 24 VAC (50 Hz and 60 Hz) during the last minute of the cycle. If the thermoactuators do not receive voltage at the correct times, change the PCB control board. If the timing and voltage are correct, replace the thermoactuator.
	Door Locking Motor	Check the door lock motor. Make sure the main is not stuck or in a bind. If motor does not move freely, replace locking motor.
	Door Rod	Check to see that door rod from locking motor to lock assy is long enough to allow lock assy to disengage. If not, adjust rod.
No hot water in detergent dispenser	Water Valve Coil	Check coil continuity at terminals and replace if no continuity. 120 VAC (60 Hz) or 24 VAC (50 Hz) power only on for 20 seconds in wash bath.
	Water Inlet	Check water inlet screens for blockage and clean screens if necessary.
	Water	Check to ensure that water is turned on and operating.
	J1 Wire Harness	Check orange & blue wires in relay harness.
Hot water does not enter tub in wash	Water Valve Coil	Check coil continuity at terminals and replace if no continuity. Check for 120 VAC (60 Hz) or 24 VAC (50 Hz) power from main relay PCB.
	Water Inlet	Check water inlet screens for blockage and clean if necessary.
	Water	Check to ensure that water is turned on and operating.
	Orange or blue wire at controller and main relay PCB	Check orange and blue wire on main PCB controller J1 connection and at PCB relay board J2 connection.
	Pressure Switch	Check pressure switch continuity between terminal contacts. If no continuity, check pressure switch hose for obstruction. If the hose is okay, then change pressure switch.
No cold water to tub in wash	Water Valve Coil	Check coil continuity at terminals and replace if no continuity. Check for 120 VAC (60 Hz) or 24 VAC (50 Hz) power from main relay PCB.
	Water Inlet Screens	Check water inlet screens for blockage and clean if necessary.
	Water	Check to ensure that water is turned on and operating.
	Orange or blue wire at controller and main relay PCB	Check orange and blue wire on main PCB controller J1 connection and at PCB relay board J2 connection.

	Pressure Switch	Check pressure switch continuity between terminal contacts. If no continuity, check pressure switch hose for obstruction. If the hose is okay, then change pressure switch.
Water comes in but level does not rise	Drain Valve (open)	Check these areas: <ul style="list-style-type: none"> • Drain valve blockage. • Drain valve motor and gear train. If there is power to the valve but drain valve does not close, replace drain valve and motor. • Power to the drain valve. If no power to drain valve, check (red/white) wire on J4-4 on PCB relay board. If there is no power on the (red/white) wire when the washer is in a wash cycle, replace relay board.
	Orange or blue wire at controller and main relay PCB	Check orange and blue wire on main PCB controller J1 connection and at PCB relay board J2 connection.
Water does not flush softener compartment	Water Valve Coil	Check coil continuity at terminals and replace if no continuity.
	Water Inlet Screens	Check water inlet screens for blockage and clean if necessary.
	Water	Check to ensure that water is turned on and operating.
Water level too high	Pressure Switch	Check for blockage in pressure switch hose. Check for pressure switch opening circuit across terminals. Replace switch if contacts do not open. Check the Molex connector and that there is 24VAC at the orange and white/orange wires on the Water Pressure Sensor.
Water drains slowly	Drain System	Check hoses and drain valve for blockage. Check to make sure building drain is of adequate size. Check building drains for blockage.
Machine does not turn	VFD	Check VFD by removing top panel. If no display, turn power off to machine at breaker for 2 minutes and turn power back on to reset. If still no display, replace VFD.
Machine tumbles in one direction	VFD	See DISPLAYED WASHER MESSAGES section for more info.
	VFD	Inspect yellow and white/yellow enable wires from main control PCB and at VFD
Excessive vibration	Mounting System	Check these areas: <ul style="list-style-type: none"> • Strength of mounting structure, concrete or base. • Mounting bolts may be loose and need tightening.
	Drive Belt	Worn drive belt can cause vibration and noise.
	Loading	Small loads contribute to out of balance loading and increase vibration.
Machine does not spin	Pressure Switch	Check the Molex connector and that there is 24VAC at the orange and white/orange wires on the Water Pressure Sensor.

Machine starts and does not operate	VFD	Check yellow and white/yellow wires from main control PCB connection J14 to the VFD.
Machine does not stop	Main PCB	Main control PCB controls the time of the cycle and the end of cycle.
	Braking Resistors	Check braking resistors for continuity. Verify ohms resistance at braking resistors with wires removed.
Water leakage around loading door	Door Adjustment	Door may need adjustment due to abuse or wear. Check tightness around perimeter using a dollar bill. Adjust left to right tightness by shims at door lock or hinge side. It is important to center gasket to tub opening before tightening door to hinge bolts. Chalk may be used on tub front to show point of contact with tub. If gasket is deformed, worn, or damaged, replace. Refer to parts section for door gasket expander kit.
Signs of a damaged E-Stop button.	Stop button	Machine accepts coins, When machines starts, the buzzer will sound, and then the machine stops. The display will then show "OPEN DOOR". Replace stop button.

7 TRANSIENT VOLTAGE SURGE SUPPRESSORS

IMPORTANT

Like most electrical equipment your new machine can be damaged or have its life shortened by voltage surges due to lightning strikes which are not covered by factory warranty. Local power distribution problems also can be detrimental to the life of electrical components. We recommend the installation of transient voltage surge suppressors for your new equipment. These devices may be placed at the power supply panel for the complete installation and don't require an individual device for each machine.

These surge protectors help to protect equipment from large spikes and also from small ongoing spikes in the power that occur on a day to day basis. These smaller surges can shorten overall life of electrical components of all types and cause their failure at a later date. Although they can't protect against all events, these protective devices have a good reputation for significantly lengthening the useful life of electronic components.

Electronic components are helped to have a longer useful life when they are supplied with the clean stable electrical power they like.

We are including the following names and links to a few suppliers of these devices for those who don't currently have a source.

MANUFACTURER

LINK

MCG Surge Protection

mcgsurge.com

Eaton Corporation

eaton.com/us/en-us

Schneider Electric

se.com/us/en

Asco Power Technologies

ascopower.com/us/en

Emerson Electric Co.

emerson.com/en-us

8 SERVICE AND PARTS

The following parts are provided with each machine for use in installation.

For T-350, 450, 650, 750

<u>Dexter Part Number</u>	<u>Description</u>	<u>Quantity</u>
9990-027-011 (60Hz)	Hose, Water Supply	2
9990-024-015 (50Hz)	Hose, Water Supply (Red end)	1
9990-024-016 (50Hz)	Hose, Water Supply (Blue end)	1
8641-242-000 (All)	Washer, Inlet Hose	2
9565-003-001 (All)	Strainer, Inlet Hose	2

For T-950, 1450, 1800

<u>Dexter Part Number</u>	<u>Description</u>	<u>Quantity</u>
9990-027-011 (60Hz)	Hose, Water Supply	2
9990-027-013 (60Hz)	Hose, Water Supply (Large)	2
9990-024-015 (50Hz)	Hose, Water Supply (Red end)	1
9990-024-016 (50Hz)	Hose, Water Supply (Blue end)	1
9990-024-017 (50Hz)	Hose, Water Supply (Red end-Large)	1
9990-024-018 (50Hz)	Hose, Water Supply (Blue end-Large)	1
8641-242-000 (All)	Washer, Inlet Hose	4
9565-003-001 (All)	Strainer, Inlet Hose	4

Contact distributor or Dexter Laundry, Inc. if a steel-mounting base is required.

For service and parts information, contact your local Dexter agent. To find your local Dexter agent, use the Distributor Locator at the website shown below. If a Dexter agent is not available, contact **Dexter Laundry, Inc.** directly as listed below:

Mailing Address: 2211 West Grimes Avenue Phone: 1-800-524-2954
Fairfield, IA 52556
USA

Website: www.dexter.com