

**COMMERCIAL DRYERS
MODELS T-30X2 AND T-50X2 VENDED
X-SERIES CONTROL, NATURAL GAS/LP HEATED**



DEXTER.
LAUNDRY

**OPERATOR'S MANUAL
INSTALLATION & OPERATION INSTRUCTIONS**

The dryer must not be stored or installed where it will be exposed to water and/or weather.

**⚠ WARNING:
FIRE OR EXPLOSION HAZARD**

Failure to follow safety warnings exactly could result in serious injury, death or property damage.

- Do not store or use gasoline or other flammable vapors and liquids in the vicinity of this or any other appliance.
- WHAT TO DO IF YOU SMELL GAS
 - Do not try to light any appliance.
 - Do not touch any electrical switch; do not use any phone in your building.
 - Clear the room, building or area of all occupants.
 - Immediately call your gas supplier from a neighbor's phone. Follow the gas supplier's instructions.
 - If you cannot reach your gas supplier, call the fire department.
- Installation and service must be performed by a qualified installer, service agency or the gas supplier.

⚠ AVERTISSEMENT. Assurez-vous de bien suivre les instructions données dans cette notice pour réduire au minimum le risque d'incendie ou d'explosion ou pour éviter tout dommage matériel, toute blessure ou la mort.

- Ne pas entreposer ni utiliser d'essence ni d'autres vapeurs ou liquides inflammables à proximité de cet appareil ou de tout autre appareil.
- QUE FAIRE SI VOUS SENTEZ UNE ODEUR DE GAZ:
 - Ne pas tenter d'allumer d'appareils.
 - Ne touchez à aucun interrupteur. Ne pas vous servir des téléphones se trouvant dans le bâtiment.
 - Évacuez la pièce, le bâtiment ou la zone.
 - Appelez immédiatement votre fournisseur de gaz depuis un voisin. Suivez les instructions du fournisseur.
 - Si vous ne pouvez rejoindre le fournisseur de gaz, appelez le service des incendies.
- L'installation et l'entretien doivent être assurés par un installateur ou un service d'entretien qualifié ou par le fournisseur de gaz.

Post the following **"For Your Safety"** caution in a prominent location:

FOR YOUR SAFETY

Do not store or use gasoline or other flammable vapors or liquids in the vicinity of this or any other appliance.

POUR VOTRE SÉCURITÉ

Ne pas entreposer ni utiliser d'essence ni d'autres vapeurs ou liquides inflammables à proximité de cet appareil ou de tout autre appareil.

It is important that you read this Manual and retain it for future reference. For service or replacement parts, contact the distributor in your area or the manufacturer.

You, the purchaser, must post in a prominent location instructions to be followed in the event the user smells gas. Consult your local gas supplier for procedure to be followed if the odor of gas is present.

FOR YOUR SAFETY

THIS MACHINE IS FOR DRYING ONLY FABRICS CLEANED IN WATER.

To avoid possibility of fire, including spontaneous combustion, do not dry oiled floor mops, items containing foam rubber or similarly textured rubberlike materials or any material on which you have used a cleaning solvent or which contains flammable liquids or solids (such as petrol, kerosene, waxes, etc.) Fabric softeners, or similar products, should be used per the fabric softener instructions. Remove all objects from pockets such as lighters and matches.

This appliance can be used by children aged from 8 years and above and persons with reduced physical, sensory or mental capabilities or lack of experience and knowledge if they have been given supervision or instruction concerning use of the appliance in a safe way and understand the hazards involved. Children shall not play with the appliance. Cleaning and user maintenance shall not be made by children without supervision. Children of less than 3 years should be kept away unless continuously supervised.

Dexter Laundry, Inc.
2211 W. Grimes
Fairfield, Iowa 52556

Table of Contents

1	WARNINGS ABOUT USE AND OPERATION	3
2	SPECIFICATIONS	5
3	DIMENSIONS	9
3.1	T-30X2 DRYER DIMENSIONS - FRONT VIEW	9
3.2	T-30X2 DRYER DIMENSIONS - SIDE VIEW	10
3.3	T-30X2 DRYER DIMENSIONS - REAR VIEW	11
3.4	T-50X2 DRYER DIMENSIONS- FRONT VIEW	12
3.5	T-50X2 DRYER DIMENSIONS - SIDE VIEW	13
3.6	T-50X2 DRYER DIMENSIONS - REAR VIEW	14
4	INSTALLATION INSTRUCTIONS	15
4.1	UNCRATING AND PLACING DRYER	15
4.2	DRYER INSTALLATION.....	15
4.2.1	CODE CONFORMITY:	15
4.2.2	INSTALLATION CLEARANCES:	15
4.2.3	MAKE-UP AIR:	16
4.2.4	ELECTRICAL REQUIREMENTS:.....	16
4.2.5	GAS REQUIREMENTS:	17
4.2.6	EXHAUST INSTALLATION:	18
4.2.7	DRYER IGNITION (SOLID STATE IGNITION):.....	19
4.2.8	MAIN BURNER ADJUSTMENT:.....	19
5	DRYER SHUTDOWN.....	19
6	DESCRIPTION OF DRYER CONTROL.....	20
7	OPERATING INSTRUCTIONS.....	20
8	PROGRAMMING THE DRYER CONTROL	21
9	DISPLAYED DRYER MESSAGES.....	27
10	SERVICING AND TROUBLESHOOTING	32
11	PREVENTIVE MAINTENANCE INSTRUCTIONS.....	34
12	Instructions - Convert a Dual Voltage Stack Dryer	35

1 WARNINGS ABOUT USE AND OPERATION

DO NOT MODIFY THIS APPLIANCE. KEEP SHIELDS, GUARDS, AND COVERS IN PLACE. These safety devices are provided to protect everyone from injury.

WARNING: Do not stop dryer before end of cycle time unless all items are quickly removed and spread out to dissipate heat.

It is **ABSOLUTELY ESSENTIAL** that the dryer be grounded to a known earth (zero) ground in accordance with local codes or, in the absence of local codes, with the latest editions of the National Electric Code, ANSI//NFPA 70 or Standard CSA C22.1 Canadian Electrical Code Part 1. This is not only for personal safety, but is necessary for proper operation of the controller. Failure to do so will void the warranty of the controller.

A DRYER SHOULD BE CONNECTED TO POWER FOR THREE (3) MINUTES before it is operated or before a program change is made. Operation or program changes, which occur during this "power up" period, are subject to loss in case of power interruption. After the initial three minutes, all programmed data is protected from power interruptions of any length and the customer's individual cycle is protected up to 3 seconds. This is done without batteries.

LEAVE THE ELECTRICAL POWER TO THE DRYER ON AT ALL TIMES except when necessary for service or other similar activities. The hour meter function adds only full hours to its reading. If the power is shut off every night, any fraction of an hour of time that is on the machine at that time will be lost. Turning the power off every night could also have some effect on the long-term life of the memory after a number of years. Turning power off occasionally won't affect the unit.

THIS DRYER IS EQUIPPED WITH AN OVER-TEMPERATURE THERMOSTAT located on the side of the burner housing for T-30X2 and T-50X2 above the gas valve (located on side of exhaust duct for T-20X2 below burner housing). Should the dryer cease to operate, refer to your "Service Procedure and Parts Data" book for instructions.

CHECK THIS THERMOSTAT WHEN INSTALLING DRYER to assure it is not tripped. Impacts such as rough handling in shipment, may trip the thermostat. It may be reset by inserting a wooden pencil or dowel through the bushing in the cover. Note: there is no cover on the T-20X2 model.

DO NOT SPRAY AEROSOLS IN THE VICINITY OF THIS APPLIANCE while in operation.

THE DRYER IS NOT TO BE USED IF INDUSTRIAL CHEMICALS HAVE BEEN USED FOR CLEANING.

THIS APPLIANCE SHALL NOT BE USED TO DRY OFF SOLVENTS OR DRY-CLEANING FLUIDS.

DO NOT PLACE ARTICLES ON OR AGAINST THIS APPLIANCE.

DO NOT DRY UNWASHED ITEMS IN THE DRYER.

ADEQUATE VENTILATION SHALL BE PROVIDED TO AVOID THE BACK FLOW OF GASES INTO THE ROOM FROM ANY FUEL BURNING APPLIANCES, INCLUDING OPEN FIRES.

Items that have been soiled with substances such as cooking oil, acetone, alcohol, petrol, kerosene, spot removers, turpentine, waxes and wax removers should be washed in hot water with an extra amount of detergent before being dried in the tumble dryer.

OIL-AFFECTED ITEMS CAN IGNITE SPONTANEOUSLY, ESPECIALLY WHEN EXPOSED TO HEAT SOURCES SUCH AS IN A DRYER. THE ITEMS BECOME WARM, CAUSING AN OXIDATION REACTION IN THE OIL. OXIDATION CREATES HEAT. IF THE HEAT CANNOT ESCAPE, THE ITEMS CAN BECOME HOT ENOUGH TO CATCH FIRE. PILING, STACKING OR STORING OIL-AFFECTED ITEMS CAN PREVENT HEAT FROM ESCAPING AND SO CREATE A FIRE HAZARD.

IF IT IS UNAVOIDABLE THAT FABRICS THAT CONTAIN VEGETABLE OR COOKING OIL OR HAVE BEEN CONTAMINATED BY HAIR CARE PRODUCTS BE PLACED IN A TUMBLE DRYER THEY SHOULD FIRST BE WASHED IN HOT WATER WITH EXTRA DETERGENT - THIS WILL REDUCE, BUT NOT ELIMINATE, THE HAZARD.



Means that care is required to avoid causing a fire by igniting flammable material.

2 SPECIFICATIONS

30 lb. Commercial Stack Dryer: T-30X2 - DC30X2N_-15ET_X (60 Hz), DC30X2N_-39AT_X (50 Hz)

Cabinet Height	76 1/4"	1937 mm.
(Assumes minimum leveling leg adjustment)		
Cabinet Width	31 1/2"	800 mm.
Cabinet Depth	49 1/2"	1257 mm.
Floor to Bottom of Door- Bottom Dryer	7 5/8"	194 mm.
Floor to Bottom of Door- Top Dryer	45 1/4"	1149 mm.
Door Opening	22 5/8"	575 mm.
Dry Wt. Capacity	30 x 2 lbs.	13.6 x 2 kg.
Cylinder Diameter	30"	762 mm.
Cylinder Depth	27 1/2"	699 mm.
Cylinder Volume	11.25 cu. ft.	319 liters
Lint Screen Area	453 sq. in.	2923 sq. cm.
Gas Input (per dryer- 60 Hz)	90,000 Btu/hr	95MJ/hr (26.4 kW)
Gas Input (per dryer- 50 Hz)	74,000 Btu/hr	78MJ/hr (21.7 kW)
Gas Supply Connection	1/2"	12.7 mm.
Natural Gas Supply (Water Column)	5" - 8"	127 mm. - 203 mm./1.25kPa – 1.99kPa
Natural Burner Manifold		
(60 Hz Water Column)	3.5"	88.9 mm./0.87kPa
(50 Hz Water Column)	3.4"	86.4 mm./0.84kPa
Propane or ULPG Supply (Water Column)	11.5" – 13.5"	292 mm. - 343 mm./2.86kPa - 3.36kPa
Burner Manifold Pressure		
Propane (60 Hz Water Column)	11"	279 mm./2.75kPa
Propane or ULPG (50 Hz Water Column)	10"	254 mm./2.50kPa
Exhaust Size	8"	203 mm.
Make-up Air	1.5 sq. ft.	1394 sq. cm.
Example: 1.5 sq. ft = 1 ft. long X 1.5 ft. wide		
Motor Size	1/2 H.P.	.373 kW
Airflow (60 Hz)	600 CFM	17.0 m ³ /min
Airflow (50 Hz)	500 CFM	14.2 m ³ /min

Electrical Specifications - 120/60/1

Voltage/Hz/Phase	120V/60Hz/1Phase
Running Amps	8.0
Circuit Protection Amps	20
Wire Size	12 gauge
Electrical Service	2 wire + ground

Electrical Specifications - 208-240/60/1

Voltage/Hz/Phase	208-240V/60Hz/1Phase
Running Amps	5.0
Circuit Protection Amps	15
Wire Size	12 gauge
Electrical Service	2 wire + ground

Electrical Specifications - 230/50/1

Voltage/Hz/Phase	230V/50Hz/1Phase
Running Amps	10.0
Circuit Protection Amps	15
Wire Size	12 gauge
Electrical Service	2 wire + ground

Shipping Weight	750 lbs.	340 kg.
Net Weight	699 lbs.	317 kg.
Clearance Behind Machines (min.)	18"	457 mm.

SPECIFICATIONS

30 lb. Commercial Stack Dryer: T-30X2 Reversing Tumbler DC30X2N_-11ET_R (60 Hz), DC30X2N_-39AT_R (50 Hz)

Cabinet Height	76 1/4"	1937 mm.
(Assumes minimum leveling leg adjustment)		
Cabinet Width	31 1/2"	800 mm.
Cabinet Depth	49 1/2"	1257 mm.
Floor to Bottom of Door- Bottom Dryer	7 5/8"	194 mm.
Floor to Bottom of Door- Top Dryer	45 1/4"	1149 mm.
Door Opening	22 5/8"	575 mm.
Dry Wt. Capacity	30 x 2 lbs.	13.6 x 2 kg.
Cylinder Diameter	30"	762 mm.
Cylinder Depth	27 1/2"	699 mm.
Cylinder Volume	11.25 cu. ft.	319 liters
Lint Screen Area	453 sq. in.	2923 sq. cm.
Gas Input (per dryer- 60 Hz)	90,000 Btu/hr	95MJ/hr (26.4 kW)
Gas Input (per dryer- 50 Hz)	74,000 Btu/hr	78MJ/hr (21.7 kW)
Gas Supply Connection	1/2"	12.7 mm.
Natural Gas Supply (Water Column)	5" - 8"	127 mm. - 203 mm./1.25kPa – 1.99kPa
Natural Burner Manifold		
(60 Hz Water Column)	3.5"	88.9 mm./0.87kPa
(50 Hz Water Column)	3.4"	86.4 mm./0.84kPa
Propane or ULPG Supply (Water Column)	11.5" – 13.5"	292 mm. - 343 mm./2.86kPa - 3.36kPa
Burner Manifold Pressure		
Propane (60 Hz Water Column)	11"	279 mm./2.75kPa
Propane or ULPG (50 Hz Water Column)	10"	254 mm./2.50kPa
Exhaust Size	8"	203 mm.
Make-up Air	1.5 sq. ft.	1394 sq. cm.
Example: 1.5 sq. ft = 1 ft. long X 1.5 ft. wide		
Motor Size-Tumbler	2 H.P.	1.492 kW
Motor Size-Blower	1/3 H.P.	.248 kW
Airflow (60 Hz)	600 CFM	17.0 m ³ /min
Airflow (50 Hz)	500 CFM	14.2 m ³ /min

Electrical Specifications - 208-240/60/1

Voltage/Hz/Phase	208-240V/60Hz/1Phase
Running Amps	10.0
Circuit Protection Amps	15
Wire Size	12 gauge
Electrical Service	2 wire + ground

Electrical Specifications - 230/50/1

Voltage/Hz/Phase	230V/50Hz/1Phase
Running Amps	10.0
Circuit Protection Amps	15
Wire Size	12 gauge
Electrical Service	2 wire + ground

Shipping Weight	750 lbs.	340 kg.
Net Weight	699 lbs.	317 kg.
Clearance Behind Machines (min.)	18"	457 mm.

SPECIFICATIONS

50 lb. Commercial Stack Dryer: T-50X2 – DC50X2N_-15ET_X (60 Hz), DC50X2N_-49AT_X (50 Hz)

Cabinet Height	79 1/4"	2012 mm.
(Assumes minimum leveling leg adjustment)		
Cabinet Width	34 1/2"	876 mm.
Cabinet Depth	54 3/4"	1391 mm.
Floor to Bottom of Door- Bottom Dryer	7"	178 mm.
Floor to Bottom of Door- Top Dryer	46"	1168 mm.
Door Opening	25 5/8"	651 mm.
Dry Wt. Capacity	50 x 2 lbs.	22.7 x 2 kg.
Cylinder Diameter	32 1/2"	826 mm.
Cylinder Depth	33"	838 mm.
Cylinder Volume	15.84 cu. ft.	448 liters
Lint Screen Area	544 sq. in.	3510 sq. cm.
Gas Input (per dryer- 60 Hz)	108,000 Btu/hr	114MJ/hr (31.7 kW)
Gas Input (per dryer- 50 Hz)	96,500 Btu/hr	102MJ/hr (28.3 kW)
Gas Supply Connection	1/2"	12.7 mm.
Natural Gas Supply (Water Column)	5" - 8"	127 mm. - 203 mm./1.25kPa – 1.99kPa
Natural Burner Manifold		
(60 Hz Water Column)	3.5"	88.9 mm./0.87kPa
(50 Hz Water Column)	3.5"	88.9 mm./0.87kPa
Propane or ULPG Supply (Water Column)	11.5" – 13.5"	292 mm. - 343 mm./2.86kPa - 3.36kPa
Burner Manifold Pressure		
Propane (60 Hz Water Column)	11"	279 mm./2.75kPa
Propane or ULPG (50 Hz Water Column)	9.6"	244 mm./2.40kPa
Exhaust Size	8"	203 mm.
Make-up Air	1.5 sq. ft.	1394 sq. cm.
Example: 1.5 sq. ft = 1 ft. long X 1.5 ft. wide		
Motor Size	3/4 H.P.	0.560 kW
Airflow (60 Hz)	650 CFM	18.4 m ³ /min
Airflow (50 Hz)	510 CFM	14.4 m ³ /min

Electrical Specifications - 120/60/1

Voltage/Hz/Phase	120V/60Hz/1Phase
Running Amps	20.0
Circuit Protection Amps	30
Wire Size	10 gauge
Electrical Service	2 wire + ground

Electrical Specifications - 208-240/60/1

Voltage/Hz/Phase	208-240V/60Hz/1Phase
Running Amps	10.0
Circuit Protection Amps	20
Wire Size	12 gauge
Electrical Service	2 wire + ground

Electrical Specifications - 240/50/1

Voltage/Hz/Phase	240V/50Hz/1Phase
Running Amps	10.0
Circuit Protection Amps	20
Wire Size	12 gauge
Electrical Service	2 wire + ground

Shipping Weight	917 lbs.	416 kg.
Net Weight	857 lbs.	389 kg.
Clearance Behind Machines (min.)	18"	457 mm.

SPECIFICATIONS

50 lb. Commercial Stack Dryer: T-50x2 Reversing Tumbler DC50X2N_-11ET_R (60 Hz), DC50X2N_-49AT_R (50 Hz)

Cabinet Height	79 1/4"	2012 mm.
(Assumes minimum leveling leg adjustment)		
Cabinet Width	34 1/2"	876 mm.
Cabinet Depth	54 3/4"	1391 mm.
Floor to Bottom of Door- Bottom Dryer	7"	178 mm.
Floor to Bottom of Door- Top Dryer	46"	1168 mm.
Door Opening	25 5/8"	651 mm.
Dry Wt. Capacity	50 x 2 lbs.	22.7 x 2 kg.
Cylinder Diameter	32 1/2"	826 mm.
Cylinder Depth	33"	838 mm.
Cylinder Volume	15.84 cu. ft.	448 liters
Lint Screen Area	544 sq. in.	3510 sq. cm.
Gas Input (per dryer- 60 Hz)	108,000 Btu/hr	114MJ/hr (31.7 kW)
Gas Input (per dryer- 50 Hz)	96,500 Btu/hr	102MJ/hr (28.3 kW)
Gas Supply Connection	1/2"	12.7 mm.
Natural Gas Supply (Water Column)	5" - 8"	127 mm. – 203 mm./1.25kPa – 1.99kPa
Natural Burner Manifold		
(60 Hz Water Column)	3.5"	88.9 mm./0.87kPa
(50 Hz Water Column)	3.5"	88.9 mm./0.87kPa
Propane or ULPG Supply (Water Column)	11.5" – 13.5"	292 mm. - 343 mm./2.86kPa - 3.36kPa
Burner Manifold Pressure		
Propane (60 Hz Water Column)	11"	279 mm./2.75kPa
Propane or ULPG (50 Hz Water Column)	9.6"	244 mm./2.40kPa
Exhaust Size	8"	203 mm.
Make-up Air	1.5 sq. ft.	1394 sq. cm.
Example: 1.5 sq. ft = 1 ft. long X 1.5 ft. wide		
Motor Size-Tumbler	2 H.P.	1.492 kW
Motor Size-Blower	1/2 H.P.	.373 kW
Airflow (60 Hz)	650 CFM	18.4 m ³ /min
Airflow (50 Hz)	510 CFM	14.4 m ³ /min

Electrical Specifications – 208-240/60/1

Voltage/Hz/Phase	208-240V/60Hz/1Phase
Running Amps	15
Circuit Protection Amps	20
Wire Size	12 gauge
Electrical Service	2 wire + ground

Electrical Specifications – 240/50/1

Voltage/Hz/Phase	240V/50Hz/1Phase
Running Amps	15
Circuit Protection Amps	20
Wire Size	3.5 mm ²
Electrical Service	2 wire + ground

Shipping Weight	917 lbs.	416 kg.
Net Weight	857 lbs.	389 kg.
Clearance Behind Machines (min.)	18"	457 mm.

3 DIMENSIONS

3.1 T-30X2 DRYER DIMENSIONS - FRONT VIEW

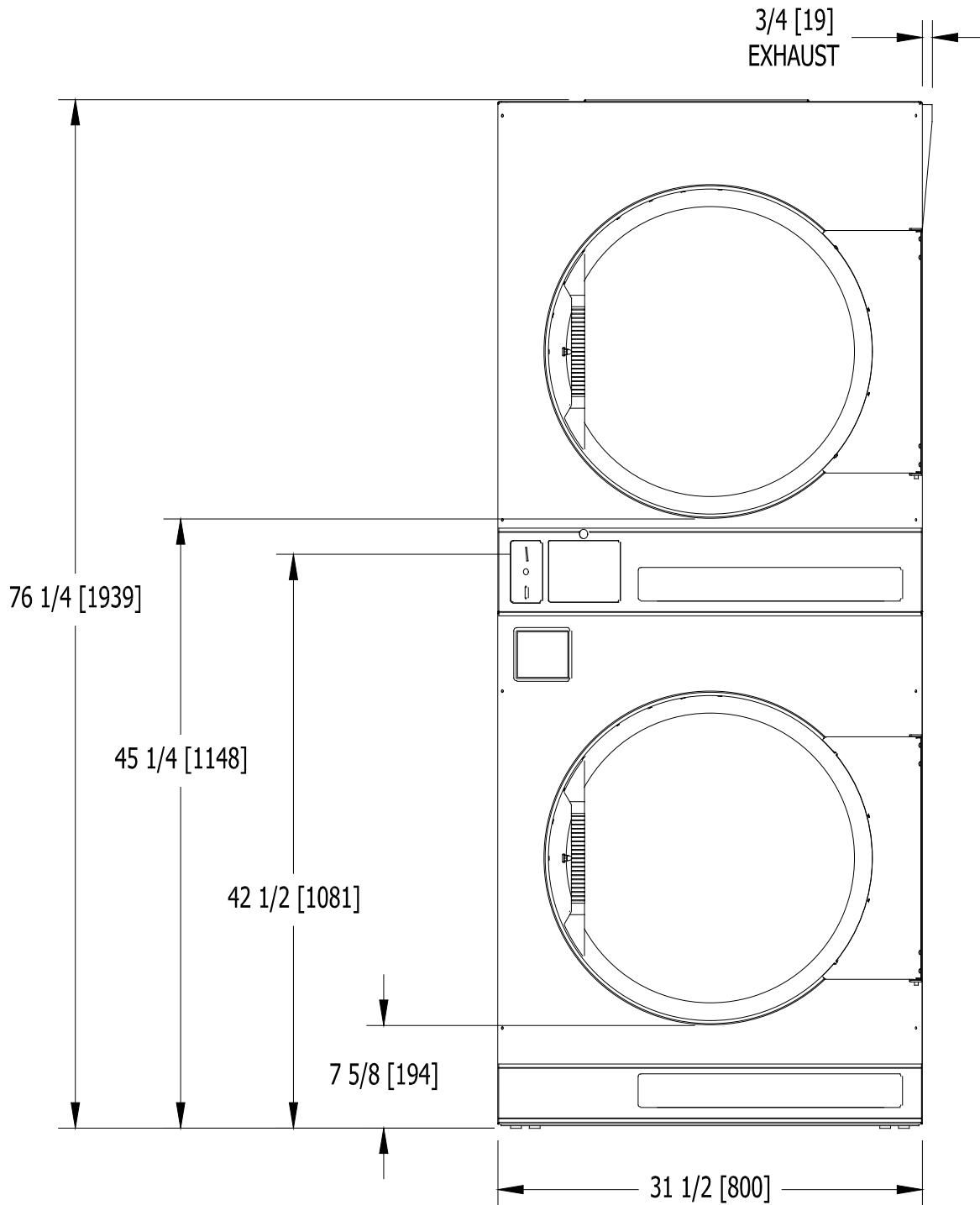

DIMENSIONS ARE IN INCHES [MILLIMETERS]

3.2 T-30X2 DRYER DIMENSIONS - SIDE VIEW

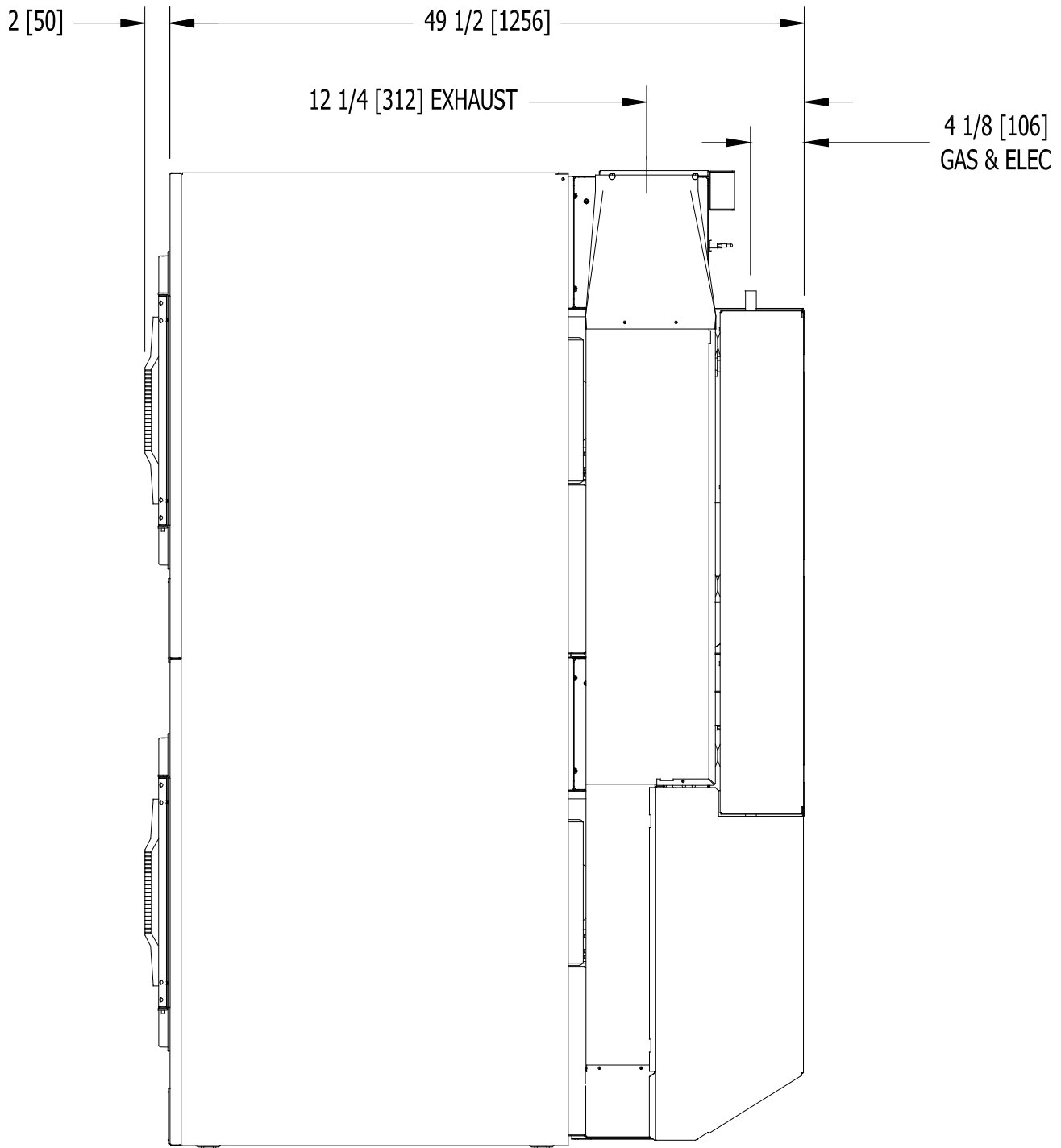

DIMENSIONS ARE IN INCHES [MILLIMETERS]

3.3 T-30X2 DRYER DIMENSIONS - REAR VIEW

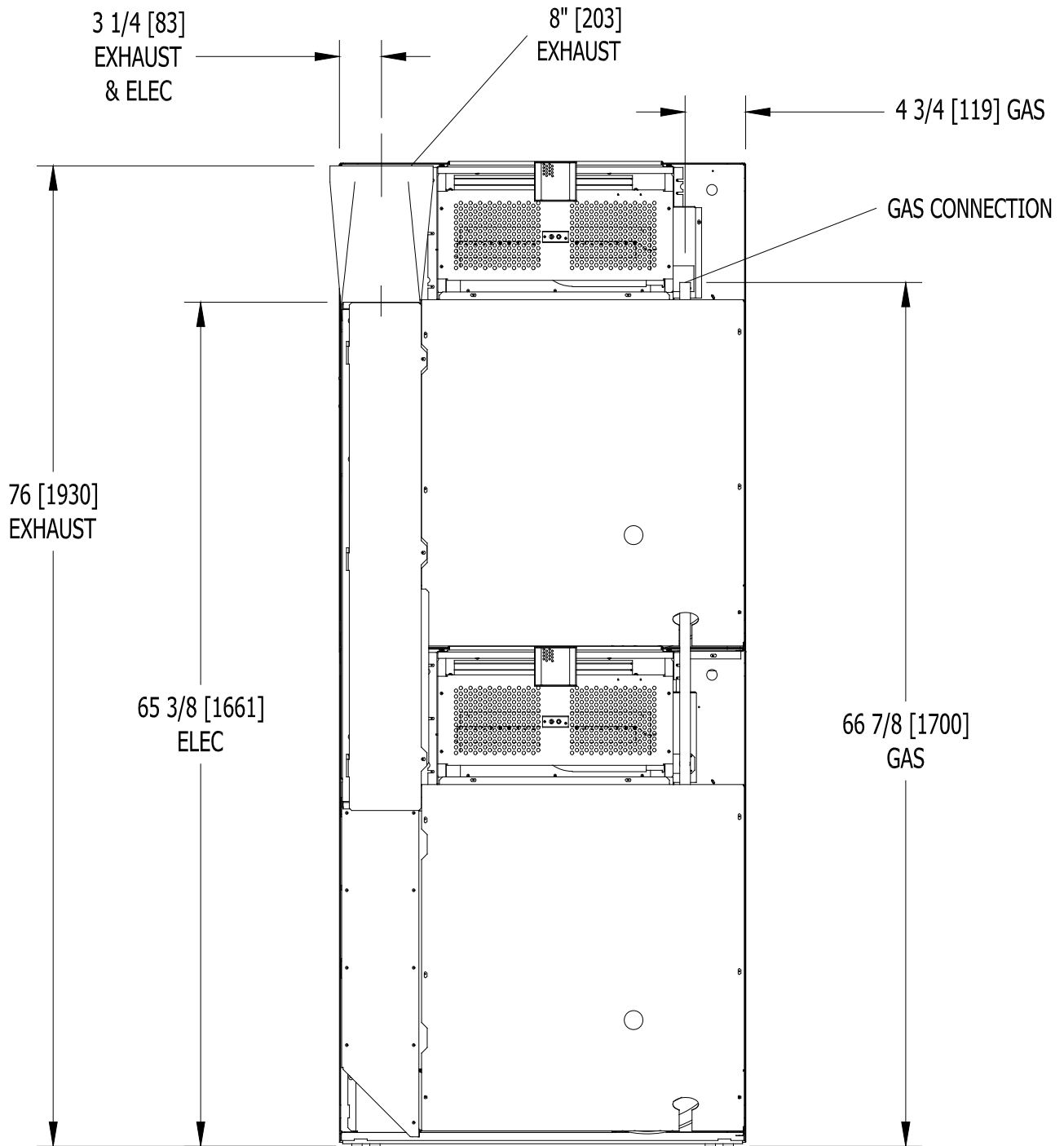

DIMENSIONS ARE IN INCHES [MILLIMETERS]

3.4 T-50X2 DRYER DIMENSIONS- FRONT VIEW

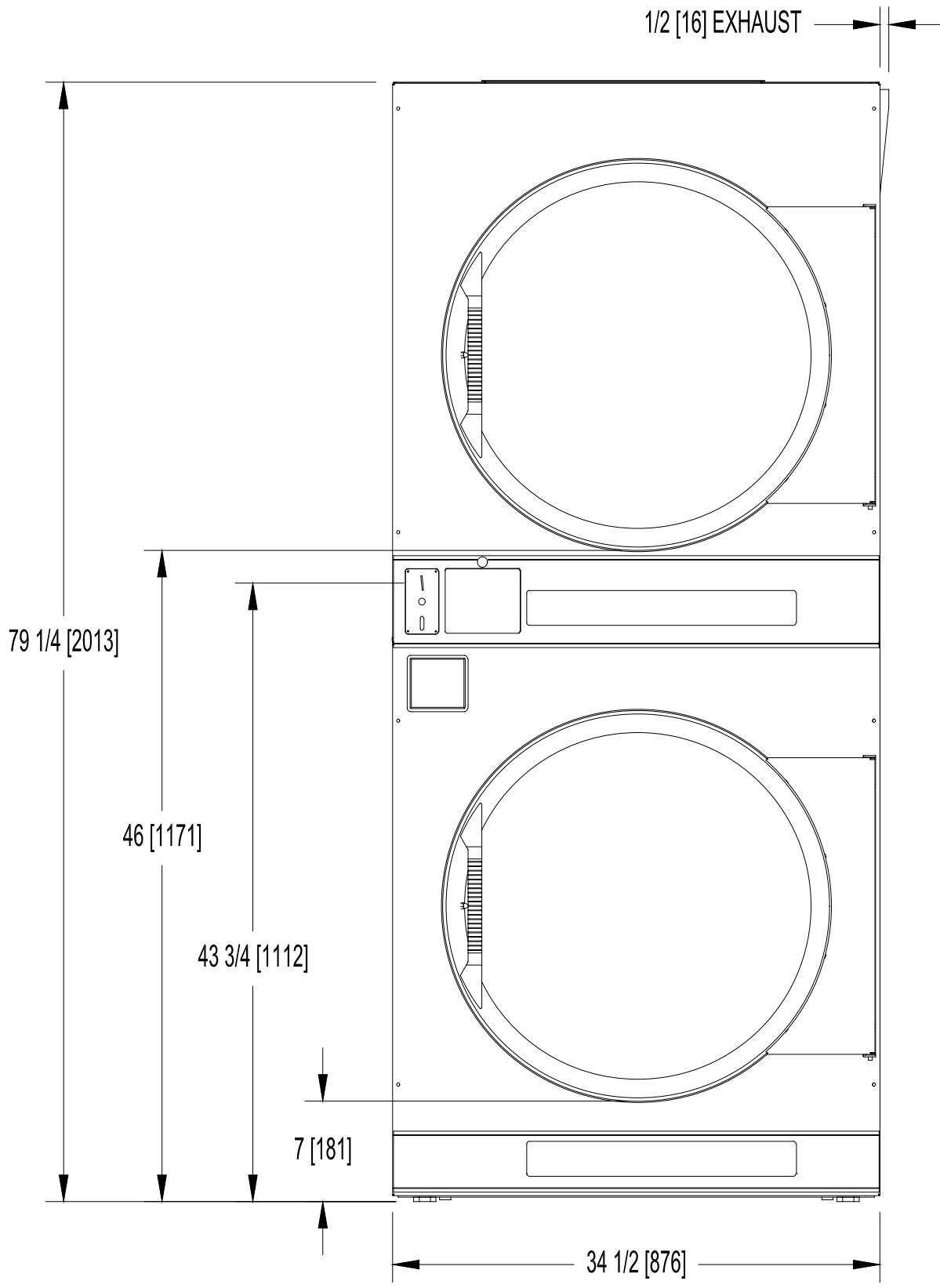

DIMENSIONS ARE IN INCHES [MILLIMETERS]

3.5 T-50X2 DRYER DIMENSIONS - SIDE VIEW

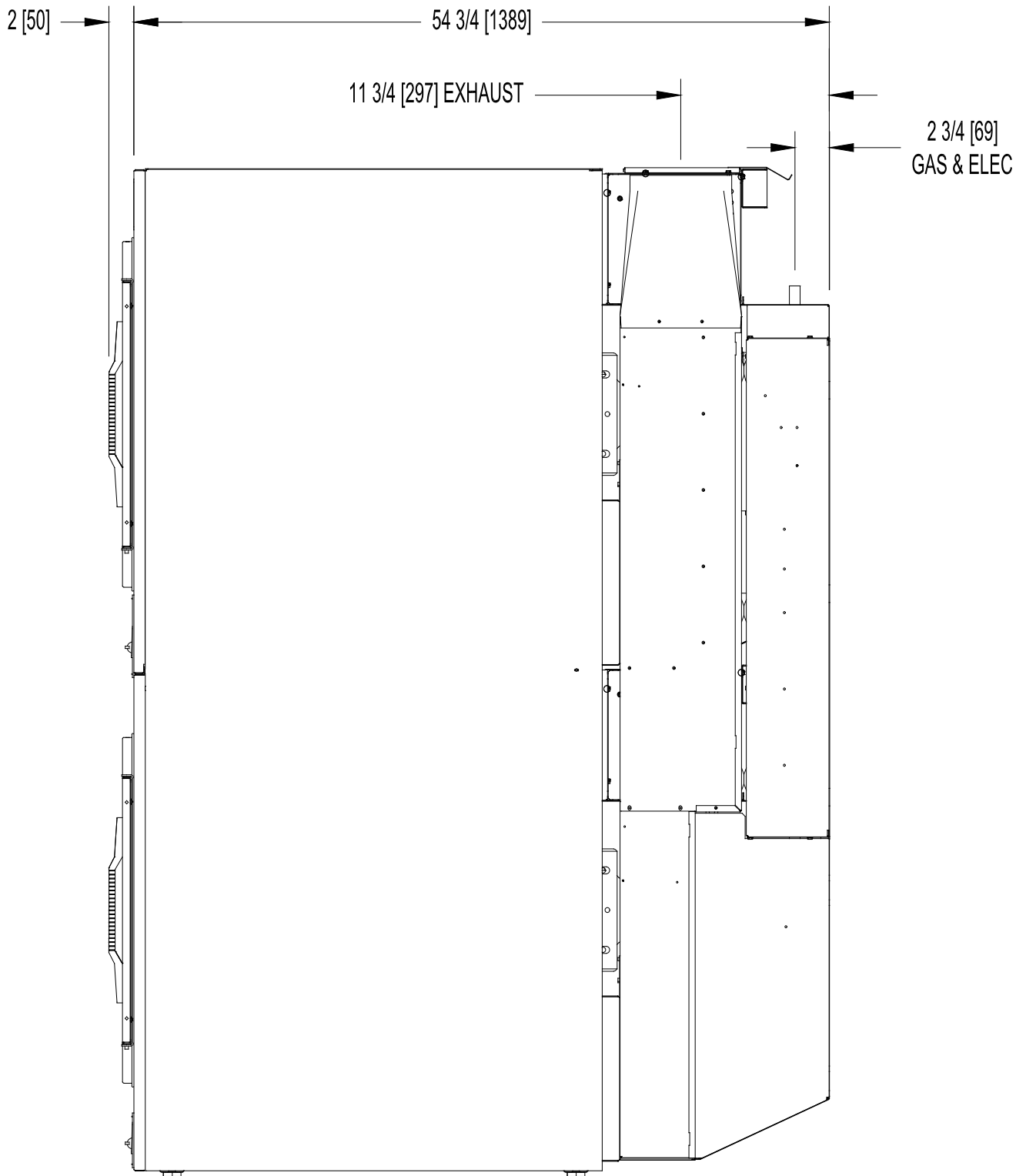

DIMENSIONS ARE IN INCHES [MILLIMETERS]

3.6 T-50X2 DRYER DIMENSIONS - REAR VIEW

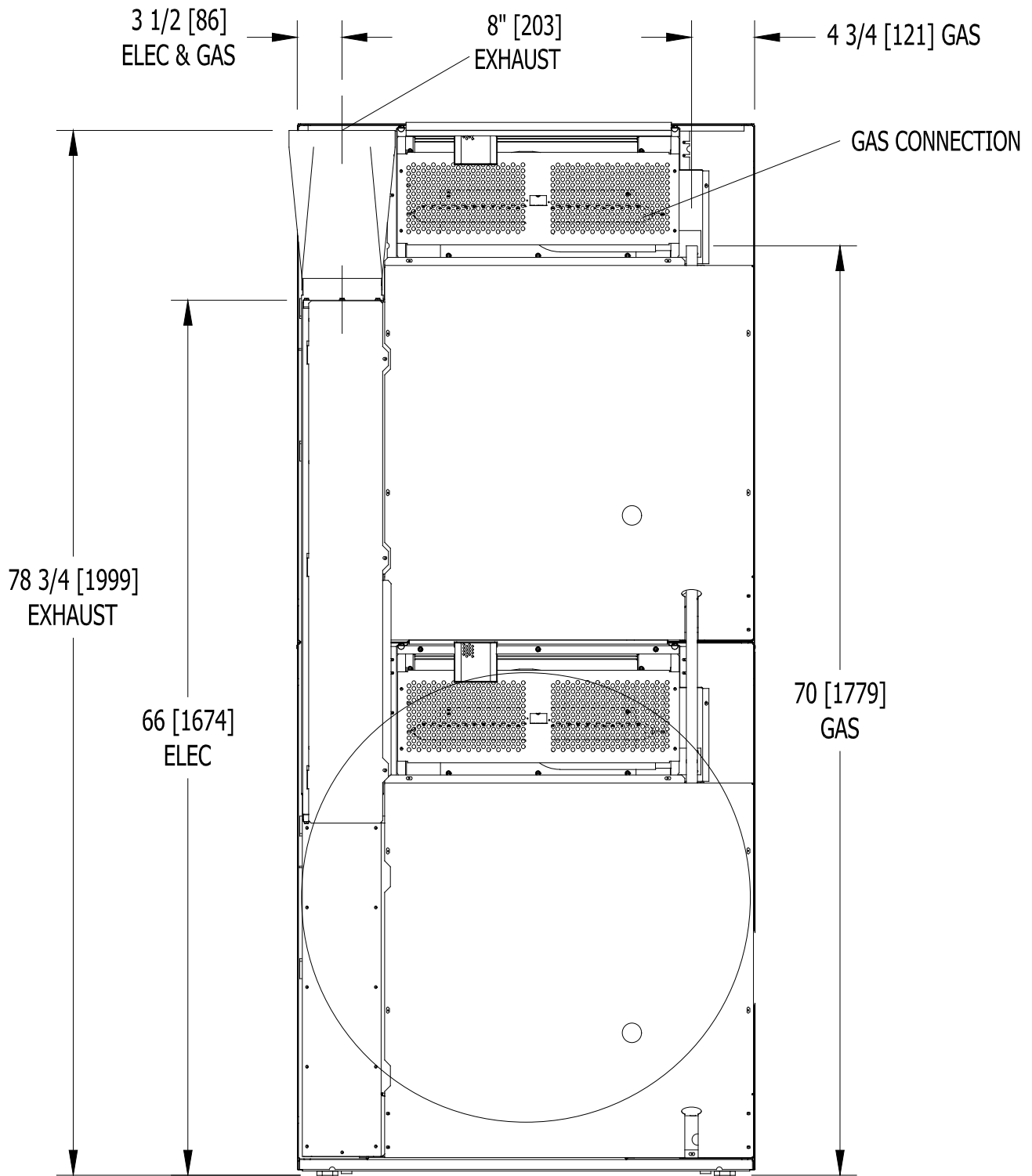

DIMENSIONS ARE IN INCHES [MILLIMETERS]

4 INSTALLATION INSTRUCTIONS

4.1 UNCRATING AND PLACING DRYER

Tools Required: 3/4" (19 mm) hex socket & ratchet driver, wood block 4" (100 mm) or 5" (125 mm) thick, a knife and a groove joint pliers, which will open to 1 3/8" (35 mm).

1. Remove and discard packaging.
2. The crate base is attached to the dryer by (4) cap screws driven upward from below the crate base. Remove crate base from dryer, by tipping dryer sidewise and place block under crate base rail in center of dryer. Using a ratchet and 3/4" hex socket, remove and discard (2) crating bolts from side, which is raised. Remove block from under crate base. Repeat for other side. Save the bolts for use if the dryer is ever moved again.
3. With a walking motion move dryer completely off crate base. Save the crate base for use if the dryer is ever moved again.
4. Slide unit into position where it will be installed. Adjust leveling legs, using the groove joint pliers, to level and align dryer with adjacent units.

Note: If the dryer is ever moved again, the dryer should be re-mounted on its crate base and its crating bolts re-inserted and tightened, in the reverse order as above.

4.2 DRYER INSTALLATION

4.2.1 CODE CONFORMITY:

All commercial dryer installations must conform with local codes, or in the absence of local codes, with the latest edition of the National Fuel Gas Code ANSI Z223.1. Canadian installations must comply with the current Standard CAN/CGA-B149 (.1 or .2) Installation Code for Gas Burning Appliances or Equipment, and local codes if applicable. Australian installations must meet installation requirements and pipe sizing requirements of AS/NZS 5601. The appliance, when installed, must be electrically grounded in accordance with the latest edition of the National Electric Code, ANSI/NFPA70, or, when installed in Canada, with Standard CSA C22.1 Canadian Electrical Code Part 1.

The appliance must not be installed behind a lockable door, a sliding door or a door with a hinge on the opposite side to that of the tumble dryer, in such a way that a full opening of the tumble dryer door is restricted.

4.2.2 INSTALLATION CLEARANCES:

This unit may be installed at the following alcove clearances:

- I. Left Side 0"
- II. Right Side 0"
- III. Back 18" (457 mm) (Certified for 1" (25 mm) clearance; however, 18" (457 mm) clearance necessary behind the motors to allow servicing and maintenance.)
- IV. Front 48" (1220 mm) (to allow use of dryer)
- V. Top Refer to figure labeled "Vertical Clearance Dimensions".
 - AB. Certification allows 0" clearance for wall framing at the top up to 18" (456 mm) back from the front. However, a 1/4" (6 mm) clearance should be allowed in case the dryer needs moving.
 - C. A 10" (250 mm) clearance is required from top at all other points.
- VI. Floor This unit may be installed upon a combustible floor.

For units installed in Australia or New Zealand, the machine must be installed on a flat surface capable of supporting 2.32 kg/cm² (40.3 psi). Do not obstruct the flow of combustion and ventilation air. Maintain minimum of 1" (25 mm) clearance between duct and combustible material. Refer to the label attached to the Belt Guard on the rear of the dryer for other installation information and start-up instructions.

4.2.3 MAKE-UP AIR:

Adequate make-up air must be supplied to replace air exhausted by dryers on all types of installations. Refer to specifications for the minimum amount of make-up air opening to outside for each dryer. This is a net requirement of effective area. Screens, grills or louvers, which will restrict the flow of air, must be considered. Consult the supplier to determine the free area equivalent for the grill being used. The source of make-up air should be located sufficiently away from the dryers to allow an even airflow to the air intakes of all dryers. Multiple openings should be provided. Openings should be a minimum of 6 feet away from exhaust outlets.

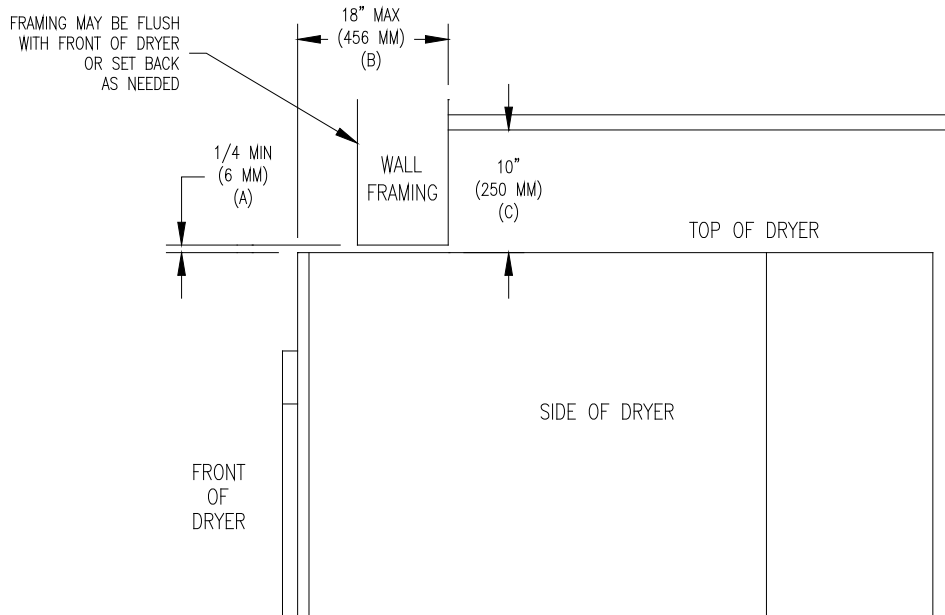

Vertical Clearance Dimensions

The sources of all make-up air and room ventilation air movement to all dryers must be located away from any dry cleaners. This is necessary so that solvent vapors will not be drawn into the dryer inlet ducts. Dry cleaner solvent vapors will decompose in contact with open flame such as the gas flame present in clothes dryers. The decomposition products are highly corrosive and will cause damage to the dryer(s) ducts and clothes loads. The operation of this appliance may affect the operation of other types of gas appliances, which take their air for safe combustion from the same room. Adequate ventilation must be provided to avoid back flow of gasses from other appliances in the same room. All other gas appliances should be tested with the Dexter dryer in operation and all the windows and doors closed. If in doubt consult the appliance manufacturer(s).

4.2.4 ELECTRICAL REQUIREMENTS:

The electrical power requirements necessary to operate the unit satisfactorily are listed on the serial plate located on the back panel of each dryer and in the specifications section of this manual. The electrical connection should be made to the terminal board, on the rear of the unit. It is absolutely necessary that the dryer be grounded to a known ground. Individual circuit breakers for each stacked dryer are required. Dryer -15 models are adjusted for 120V as shipped. They can be converted to 208-240V as required. Instructions for this conversion are located at this end of this manual.

The installer must provide a disconnect switch which will interrupt both lines. It may be a local or national requirement to provide an electrical interruption switch visible and accessible from the room in which the dryer is installed. The wiring diagram is located on the back of the door of the rear control box assembly of the dryer.

IMPORTANT: TRANSIENT VOLTAGE SURGE SUPPRESSORS

Like most electrical equipment, your new machine can be damaged or have its life shortened by voltage surges due to lightning strikes which are not covered by factory warranty. Local power distribution problems also can be detrimental to the life of electrical components. We recommend the installation of transient voltage surge

suppressors for your new equipment. These devices may be placed at the power supply panel for the complete installation and don't require an individual device for each machine.

These surge protectors help to protect equipment from large spikes and also from small ongoing spikes in the power that occur on a day to day basis. These smaller surges can shorten overall life of electrical components of all types and cause their failure at a later date. Although they can't protect against all events, these protective devices have a good reputation for significantly lengthening the useful life of electronic components. Electronic components are helped to have a longer useful life when they are supplied with the clean stable electrical power they like.

We are including the following names and phone numbers of a few suppliers of these devices for those who don't currently have a source.

<u>MANUFACTURER</u>	<u>CONTACT</u>	<u>PHONE</u>
Innovative Technology, Inc	Factory	1-800-647-8877 or www.itvss.com
EFI Electronics Corporation	Factory Distributor – Surge Pro	1-800-877-1174 or www.efinet.com 1-877-233-0153
MCG Surge Protection	Factory	1-800-851-1508 or www.mcgsurge.com
Advanced Protection Technologies Inc.	Factory	1-800-237-4567 or info@aptvss.com

4.2.5 GAS REQUIREMENTS:

The complete gas requirements necessary to operate the dryer satisfactorily are listed on the serial plate located on the back panel of the dryer and in the specifications section of this manual. The inlet gas connection to the unit is 1/2-inch [12.7] pipe thread. However, the size of the piping to supply the dryer should be determined by reference to the National Fuel Gas Code ANSI Z223.1A and consultation with the local gas supplier.

An individual gas shutoff valve is recommended for each dryer and may be required by local code (not supplied).

A joint compound resistant to the action of liquefied petroleum gases should be employed in making pipe connections.

All pipe connections should be checked for leakage with soap solution. Never check with an open flame.

A drip tee should be provided in the gas piping entering the unit to catch dirt and other foreign articles.

A 1/8 inch [3.2] NPT threaded test port, accessible for test gage connection, must be installed immediately upstream of the gas supply connection to the dryer(s) to check the supply pressure. A single test port may be used for a group of dryers where the gas is supplied by a manifold. Test and adjust the supply pressure to ensure compliance with the specification listed on the serial plate.

The recommended natural gas supply pressure is 7 inches water column (17.8 cm) at each dryer.

There is a plugged 1/8 inch [3.2] NPT threaded test port in the end of the burner manifold for checking the manifold pressure. With the burner in operation, check and adjust the dryer's gas control valve to ensure compliance with the specification listed on the serial plate for manifold pressure.

After testing, be sure to replace the 1/8 inch [3.2] NPT plugs in the manifold and in the supply line test port using joint compound before operating the dryer.

For altitudes above 2,000 feet (610m), it is necessary to derate the BTU input. Contact your local distributor for instructions.

L.P. gas conversion kits are available for this dryer. Contact your local distributor.

CAUTION: The dryer must be disconnected from the gas supply piping system during any pressure testing of that system. Do not expose the dryer's gas control valve to testing pressure.

4.2.6 EXHAUST INSTALLATION:

Exhausting of the dryer(s) should be planned and constructed so that no air restrictions occur. Any restriction due to pipe size or type of installation can cause slow drying time, excessive heat, and lint in the room. From an operational standpoint, incorrect or inadequate exhausting can cause a cycling of the high limit thermostat, which shuts off the main burners and results in inefficient drying. The exhaust duct connection near the top of the dryer will accept an 8" (200 mm) round duct. Individual exhausting of the dryers is recommended. All heat, moisture, and lint should be exhausted outside by attaching a pipe of the proper diameter to the dryer adapter collars and extending it out through an outside wall. This pipe must be very smooth on the inside, as rough surfaces tend to collect lint, which will eventually clog the duct and prevent the dryer from exhausting properly. All elbows must be smooth on the inside. All joints must be made so the exhaust end of one pipe is inside the next one downstream. The addition of an exhaust pipe tends to reduce the amount of air the blower can exhaust. This does not affect the dryer operation if held within practical limits. For the most efficient operation, it is recommended that no more than 14 ft. (4.25 m) of straight 8 in. diameter pipe with two right angle elbows be used for each cylinder.

Maintain a minimum of 1" (25mm) clearance between duct and combustible material.

If the exhaust pipe passes through a wall, a metal sleeve of slightly larger diameter should be set in the wall and the exhaust pipe passed through this sleeve. This practice is required by some local codes and is recommended in all cases to protect the wall.

This type of installation should have a means provided to prevent rain and high winds from entering the exhaust when the dryer is not in use. A hood with a hinged damper can be used for this purpose. Another method would be to point the outlet end of the pipe downward to prevent entrance of wind and rain. In either case, the outlet should be kept clear, by at least 24 in. (610 mm) of any objects, which would cause air restriction. Never install a protective screen over the exhaust outlet.

When exhausting a dryer straight up through a roof, the overall length of the duct has the same limits as exhausting through a wall. A rain cap must be placed on top of the exhaust and must be of such a type as to be free from clogging. The type using a cone shaped "roof" over the pipe is suitable for this application. Do not use an unlined masonry chimney as the flue for this appliance. Exhausting the dryer into a chimney or under a building is not permitted. In either case there is a danger of lint buildup, which can be highly combustible.

NOTE: Exhaust air must not be discharged into a flue which is used for exhausting fumes from appliances burning gas or other fuels.

Installation of several dryers, where a main discharge duct is necessary, will need the following considerations for installation (see figure below). Individual 8" (200 mm) exhaust ducts from each dryer should enter main discharge duct at a 45-degree angle in the direction of discharge airflow.

NOTE: Never install the individual ducts at a right angle into the main discharge duct. The individual ducts from the dryers can enter at the sides or bottom of the main discharge duct. Figure 3 indicates the various round main duct diameters to use with the individual dryer ducts. The main duct can be rectangular or round, provided adequate airflow is maintained. The total exhausting (main discharge duct plus duct outlet from the dryer) should not exceed the equivalent of 14 ft. (4.25 m) and two elbows. The diameter of the main discharge duct at the last dryer must be maintained to exhaust end.

NOTE: A small diameter duct will restrict airflow; a large diameter duct will reduce air velocity - both contributing to lint build up. An inspection door should be provided for periodic clean out of the main duct.

NOTE: STATIC BACK PRESSURE should be a maximum of 0.3 in. w.c. (7.6 mm w.c.) at the rear exhaust outlet of the dryer. If multiple dryers are connected to the common duct, ensure the back draft damper is installed properly.

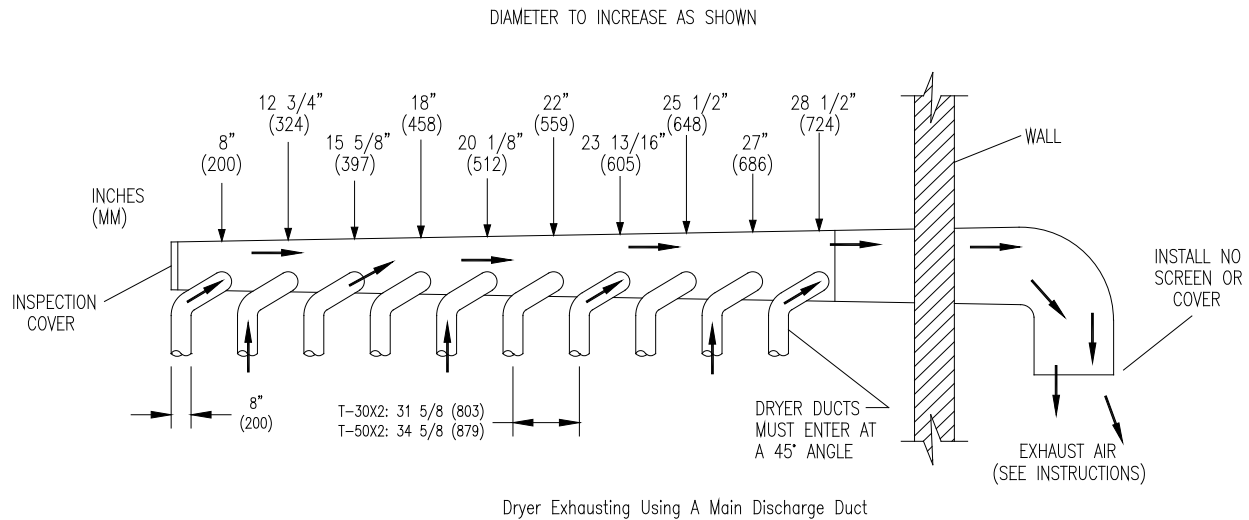

4.2.7 DRYER IGNITION (SOLID STATE IGNITION):

The solid-state ignition system lights the main burner gas by spark. The gas is ignited and burns only when the gas-relay (in the electronic controller) calls for heat. The procedure for first-time starting of a dryer is as follows.

- i. First review and comply with the "Warnings About Use and Operation" found on the inside front cover of this manual. Be sure electrical power is connected correctly. The dryer must be properly grounded.
- ii. Make sure all gas supply lines are purged of air. Close the main gas shut-off valve and wait for five minutes before turning it back on.
- iii. Turn on the main electrical power switch. The dryer may be started by following the "Operating Instructions" found later in this manual.
- iv. Natural gas and LPG fired dryers operate in the same manner. When the gas valve relay contacts are closed (indicating a demand for heat), the solid-state ignition control will automatically supply energy to the redundant gas valve. Sparking will continue until a flame is detected by the sensing probe, but not longer than ten seconds. If the gas fails to ignite in 10 seconds, the gas valve closes and the gas system pauses to allow gas to purge from the inside of the dryer. After the pause, the ignition control repeats the ignition trial cycle twice more. If the gas system fails to detect ignition after the three attempts, the system will "lock out". No further attempts will be performed automatically. To reset the ignition control electrical power to the ignition control must be interrupted. This can be done by opening the dryer door (stopping the dryer) for 15 seconds. Closing the door and pushing the "Start" button will repeat the ignition trial cycle.

4.2.8 MAIN BURNER ADJUSTMENT:

The primary air shutter of each main burner must be properly adjusted for the correct air-gas ratio. Loosen the shutter locking screw. Adjust the shutter by closing it sufficiently to give a blue flame with a yellow tip. Next open the shutter until the yellow tips are at a minimum. After adjustment securely lock each shutter in position by tightening the shutter locking screws.

5 DRYER SHUTDOWN

To render the dryer inoperative, turn off the main gas shut off valve and disconnect the electrical supply to the dryer.

NOTE: The installer must test the dryer for operation and instruct the user before leaving the installation.

6 DESCRIPTION OF DRYER CONTROL

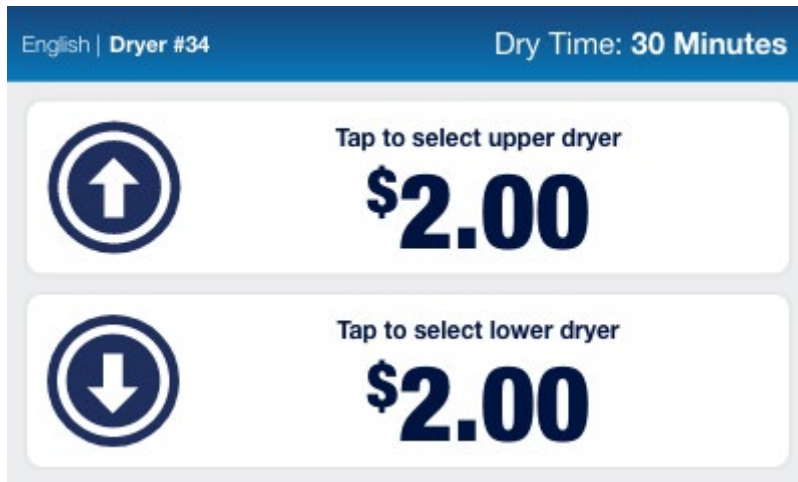

Both dryers are operated by the controller at the left midpoint of the dryer. The controller is a display UI with separate sections for the upper and lower pockets.

When vend has been applied, the control will prompt the user to press the "PRESS HERE TO START OR CHANGE OPTIONS" button for the pocket. Time is not added until this occurs for either the upper or lower dryer. If no purchased time is available on the control, the vend price is displayed.

The drying program (temperature) selected by the user is indicated on the UI when the dryer is in use. When the dryer is in use, the drying temperature may be displayed by holding down the cycle progress arrow symbol next to the cycle time remaining for the running pocket.

7 OPERATING INSTRUCTIONS

STARTING THE DRYER

1. Load clothes into either the upper or lower dryer (or both). Close the door(s) completely.
2. Make the appropriate cycle selections, if any, and vend the machine equal to or greater than the displayed vend price. Time is not added until this occurs for either the upper or lower dryer.
3. Select the "Press Her to Start" button to start the dryer. This will display the drying time purchased.

RUNNING THE DRYER

-Opening the door will stop the dryer. The dryer will restart if time has not expired upon closing the door and pressing the "Select to Resume Cycle" button.

-Selected temperature may be changed at any time.

-Running time may be extended by applying vend to meet the Extend Vend and pressing the "Tap to Add XX:XX" prompt for the pocket. The time will then be added to the current remaining cycle time, and "XX:XX Added" will be displayed on the pocket for the total amount of extended time. Unless time has expired, the controller will accept vend whether or not the original vend price is equaled.

-If time has run out, the dryer must be restarted as if it was at the beginning of drying the load, which required meeting or exceeding the vend price.

-Clothes should be removed promptly after the cycle is completed to prevent excessive wrinkling.

-Cool-down time (owner programmable) is always part of the cycle time to prevent damage from heat and is purchased by the customer. For example, if the cool-down time is 2 minutes, then the last 2 minutes of the cycle will have no heat.

8 PROGRAMMING THE DRYER CONTROL

The dryer control can be programmed to prompt the user for alternate vend prices, change dryer cycle times, temperatures, and many other options. This can be accomplished in two ways:

1. Manual programming utilizing the display UI screen.
2. USB download of a customizable User File. For instructions on using the USB download feature, please contact your local Dexter distributor or visit DexterLive.com.

MANUAL PROGRAMMING:

The dryer must be in idle mode for the manual programming menus to be accessed. Idle mode is when the dryer is not actively running a drying cycle, and the vend price is displayed on the screen.

To enter the manual programming mode, the control tray on the dryer must be unlocked and pulled out to reveal the programming button. The programming button is then pressed for 1 second. The control should display the manual programming home page.

See the figure below for the location of the programming button on the control tray.

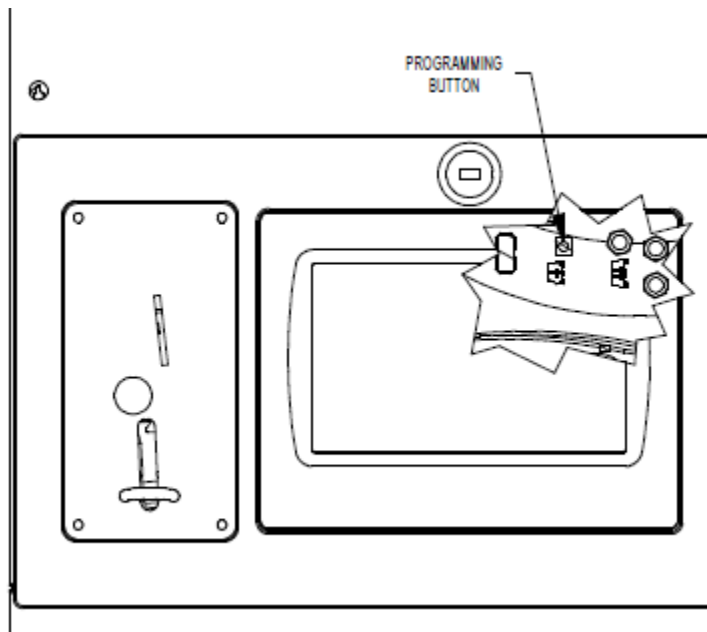

The table below shows the top-level menu. Choosing an option from the top-level menu will then display the next level of options (the sub menu).

System Info.
General
Profiles
Usage
Error Logs
Factory Reset

SYSTEM INFO.:

The System Info. Menu displays important technical information for the control. No changes can be made on this screen. See below for detailed information on each sub menu.

1. "Model Id": The Model Id is the machine model type.
2. "SW Version": The SW Version is the current software version running on the control.
3. "Drive ID": The Drive ID is the Variable Frequency Drive's identification number.
4. "DexterLive ID": The DexterLive ID is the unique MAC address of the control. It allows the control to be recognized by network routers.
5. "IP Address": The IP Address is the identifier given to the control by a network system.
6. "Location Number": The Location Number is the DexterLive's location number the control is connected to.
7. "DexterPay Status": The DexterPay Status shows whether the control is connected to a DexterPay location.

System Info.	
Model Id	Model Number
SW Version	XX.X.XXXX
Drive ID	XX.XX.XX
DexterLive ID	XX:XX:XX:XX:XX:XX
IP Address	XXX.XXX.XXX.XXX
Location Number	XXXXX
DexterPay Status	Enabled or Disabled

GENERAL:

The "General" Menu allows for the user to make various programming changes to change how the control operation affects the customer. See below for detailed information on each sub menu option.

1. "Out of Service" – The control can be put into an Out-of-Service mode via manual programming. When the mode is "On", the control will display "Out of Service". The machine will not react to any vend input and will not operate when in this mode. The factory default is "Off".
2. "Language" – The control uses English for the default language of the customer prompts. Alternatively, the user can choose Spanish, French, Italian, Greek, Malay, Korean, Japanese, Simplified Chinese, or Traditional Chinese for the customer display prompts. However, all other prompts, such as Manual Programming, USB Programming and any Error Codes will still display in English.
3. "Currency" – The Currency setting displays which currency symbol is displayed as part of the revenue. This is a non-editable setting in manual programming but can be configured using DexterLive. The factory default is "\$".
4. "PassCode" – If the user programs the Passcode to any value other than 0000, the control will prompt the user to enter a Passcode (the programmed value) before manual programming can be accessed. The factory default is "0000" (no Passcode).
 - a. Note that if the user forgets the Passcode, it can be reset to factory default (no Passcode), by performing a Factory Reset on the control. Please refer to the appropriate section of this manual to understand how to perform a Factory Reset.

- b. The individual digits of the Passcode can be set by typing with the virtual number pad. Once all four correct digits are entered, the screen will advance to the Manual Programming menu.
5. "End of Cycle Sounds" – If the user programs the End of Cycle Sounds to "Off", the control will not sound the enunciator at the end of a drying cycle. The factory default is "On".
 6. "On Tap Sounds" – If the user programs the On Tap Sounds to "On", the control will sound every time the screen is tapped. The factory default is "Off".
 7. "Screen Color" – If the user programs the Screen Color to "Dark", the screen will be in dark mode. The factory default is "Light".
 8. "Display DexterPay ID" – If the user programs the Display DexterPay ID to "On", the DexterPay ID number for the machine will be shown on the screen. The factory default is "Off".
 9. "Date/Time" – The control uses a Real Time Clock (RTC) to internally track the time and date. The RTC continues operation even if the control loses external power. The RTC is set for Central Standard Time. The time can either be represented in 12 or 24 hour time. However, if a problem occurs and the RTC time is not accurate, it can be reset to the current time using this option when the control detects an outside network connection (via Ethernet port). The Time Zone change selected will shift the Real Time Clock (RTC) time stored in the control to the appropriate choice.
 10. "View Non-Critical Errors" – If the user programs the View Non-Critical Errors to "Off", the control will not display the non-critical errors (non-cycle ending errors) if they occur during the cycle. These errors will still be logged in the Error Log. The factory default is "On".
 11. "Temperature Scale" – If the user programs the value to "Fahrenheit", then the temperatures will be displayed in Fahrenheit units. If it is programmed to "Celsius", then the temperatures will be displayed in Celsius units. The factory default is "Fahrenheit".
 12. "Left Coin Value" – The user can program the value for the left coin acceptor input. The factory default is 0.25.
 13. "Right Coin Value" – The user can program the value for the right coin acceptor input. The factory default is 1.00.

General		
Out of Service	Upper Pocket	On or Off
	Lower Pocket	On or Off
Language	English, Spanish, French, Italian, Greek, Malay, Korean, Japanese, Simplified Chinese, Traditional Chinese	
Currency	Select Currency	
PassCode	0000 through 9999	
End of Cycle Sounds	On or Off	
On Tap Sounds	On or Off	
Screen Color	Light or Dark	
Display DexterPay ID	On or Off	
Date/Time	Time Zone	PST/MST/CST/EST/etc.
	Time Format	12hr or 24hr
	Time	
	Date	
View Non-Critical Errors	On or Off	
Temperature Scale	Celsius or Fahrenheit	
Left Coin Value	0.01 through 999.99	
Right Coin Value	0.01 through 999.99	

PROFILES:

The Profiles Menu allows the user to configure the pricing and cycle settings for the machine. See below for detailed information on each sub menu option.

1. "Pricing": This option allows the user to set each cycle's base and adder prices. If the machine is a Reversing model, the Reversing price is set here.

- a. "Base Vend": The Base Price field is the price of the cycle without factoring in any additional pricing included in the cycle for both pockets. Upper and Lower dryer pockets can be priced separately. The factory default is 0.25.
- b. "Extend Vend": The Extend Vend field is the price for each dry time extension that is added before the start of the cycle, during the cycle, or at the End of Cycle Extend Dry, if End of Cycle Extend Dry is enabled. The factory default is 0.25.
- c. "Reversing" (Reversing models only): The Reversing field is the price of the Reversing option which can be purchased before the start of the cycle. The factory default is 0.00.

Pricing	
Base Vend	0.00 through 999.99
Extend Vend	0.00 through 999.99
Reversing (Reversing models only)	0.00 through 999.99

- 2. "Cycles": This option allows the user to configure each drying cycle's time settings.
 - a. "Base Cycle Time": The Base Cycle Time field is the time that the customer has available once they've met the Base Vend price.
 - b. "Free Vend Time": The Free Vend Time field is the cycle time that the customer has available if the Base Vend price is set to 0.00.
 - c. "Extend Time": The Extend Time field is the time for each dry time extension that is added to the total cycle time prior to the start of the cycle as part of the cycle setup, during the cycle, or at the End of Cycle Extend Dry.
 - d. "Maximum Cycle Time": The Maximum Cycle Time field is the maximum amount of time that can be purchased for a cycle. This includes the total time purchased before, during, and after the cycle. The factory default is 120 minutes.

Cycles	
Base Cycle Time	1:00 to 120:00
Free Vend Time	1:00 to 120:00
Extend Time	1:00 to 120:00
Maximum Cycle Time	1:00 to 120:00

- 3. "Temperature Settings": This option allows the user to choose temperature set points, within a designated range, for Low, Medium, and High temperatures or choose No Heat for the drying cycle.
 - a. "No Heat": If the user programs the No Heat to "On", the gas valve relays are not activated at any time during the cycle. The factory default is "Off".
 - b. "High": The High temperature field allows the user to set the cycling temperature for High and its Cooldown time, which is the designated time at the end of the cycle where the gas valve relay is turned off. The factory defaults are 175-°F and 4 minutes, respectively.
 - c. "Medium": The Medium temperature field allows the user to set the cycling temperature for Medium and its Cooldown time, which is the designated time at the end of the cycle where the gas valve relay is turned off. The factory defaults are 150-°F and 2 minutes, respectively.
 - d. "Low": The Low temperature field allows the user to set the cycling temperature for Low and its Cooldown time, which is the designated time at the end of the cycle where the gas valve relay is turned off. The factory defaults are 125-°F and 2 minutes, respectively.

Temperature Settings		
No Heat	On or Off	
High	Temperature	150 to 190
	Cooldown	4 to 10 minutes
Medium	Temperature	120 to 165
	Cooldown	2 to 10 minutes
Low	Temperature	110 to 150
	Cooldown	0 to 10 minutes

4. "Options": This option allows the user to set temperature and more cycle settings for the drying cycle.
 - a. "Default Temperature": The Default Temperature field allows the user to choose which general temperature setting ("LOW", "MEDIUM", or "HIGH") or "NO_HEAT" the control will default to at the beginning of each cycle if the customer does not make a choice. The factory default is "MEDIUM".
 - b. "Moisture Detection": If the user programs the Moisture Detection to "On", the dryer will use an algorithm to detect when the load is dry to help reduce gas usage. For dry cycles that require vend to start the cycle, when Moisture Detection is triggered, the pocket will change to the Low temperature for the remainder of the cycle. For Free dry cycles, the cycle will go to Cooldown once the Moisture Detection is triggered. The factory default is "Off".
 - c. "End of Cycle Extend Dry": The End of Cycle Extend Dry field allows the user to choose whether a customer is allowed to add Extend Dry time for up to 60 seconds after the dryer door is opened after a completed cycle. The factory default is "On".
 - d. "Anti-Wrinkle": The Anti-Wrinkle feature allows the user to choose whether the dryer periodically rotates after a cycle is complete. If the door was closed at the end of the cycle and is left closed for 5 minutes, the enunciator will sound, and a 5 second countdown is shown on the display UI before Anti-Wrinkle mode is entered. 5 seconds later, the dryer motor will turn on for 60 seconds and then turn off. The gas valves will not be turned on. An Anti-wrinkle message will be displayed throughout the time the motor is turned on. The factory default is "On".
 - e. "Free Dry Extensions": When Free Dry Extensions is disabled, any vend that is applied while the dryer is in "FREE" dry mode will be lost without credit. When set to "On", any vend that is applied while the dryer is in "FREE" dry mode will be used to purchase cycle extensions and will use the configured Extend Dry price and time settings. The factory default is "Off".
 - f. "Reversing" (Reversing models only): The Reversing field allows the user to choose whether the dryer reverses at 60 second intervals during the drying cycle. The factory default is "CYCLE".
 - i. OFF – Adder is disabled
 - ii. OPTION_ON – Adder is available but defaulted to the "On" state
 - iii. OPTION_OFF – Adder is available but defaulted to the "Off" state
 - iv. CYCLE – Adder is included in the cycle. There is not an option to exclude from the cycle

Options	
Default Temperature	No_Heat, Low, Medium, or High
Moisture Detection	On or Off
End of Cycle Extend Dry	On or Off
Anti-Wrinkle	On or Off
Free Dry Extensions	On or Off
Reversing (Reversing models only)	Off, Cycle, Default_Off, or Default_On

USAGE:

The Usage menu allows for the user to track data about machine usage. See below for detailed information on each sub menu option.

1. "Coin Vault": The Coin Vault field contains all the coin information for the machine with the following fields:
 - a. "Revenue Since Last Reset": The revenue since last reset field shows the accumulated revenue amount since the control had the coin vault last reset.
 - b. "Left Amount": The left amount field shows the total revenue amount from the left coin input since the control had the coin vault last reset.
 - c. "Right Amount": The right amount field shows the total revenue amount from the right coin input since the control had the coin vault last reset.
 - d. "Left Input": The left input amount shows the accumulation of coin pulses that were sent to the control over the left coin input. Note that this is a count of coin pulses, not an accumulated report of vend value.

- e. "Right Input": The right input amount shows the accumulation of coin pulses that were sent to the control over the right coin input. Note that this is a count of coin pulses, not an accumulated report of vend value.
 - f. "Display Message": If the user programs the Display Message to "On", the display will show a screen that indicates the coin box has been removed. This screen will be displayed for 30 seconds. When the coin box is reinserted into the coin vault, the UI will prompt the user to reset the coin count. This prompt will also display for 30 seconds. If set to "Off", the "Coin Box Removed" screen will not be displayed when the coin box is removed. The user can still reset the coin box via Manual Programming. The factory default is "On".
 - g. "Reset Type": If the user programs the Reset Type to "MANUAL", the user can reset the coin audit values manually via Manual Programming or when the Coin Box message is displayed. If the user programs the Reset Type to "AUTO", the coin audit values will automatically be reset when the control detects the coin box has been removed and does not require user input to reset the coin audit values. The factory default is "MANUAL".
 - h. "Reset Options": This option controls which options get reset when coin vault resets occur. If the user programs the Reset Options to "LEFT", only the Left Input and Left Amount values will be reset. If the user programs "RIGHT", only the Right Input and Right Amount values will be reset. If the user programs "BOTH", both Left and Right Input and Amount values will be reset. The factory default is "BOTH".
 - i. "Reset History": Each coin vault reset will be stored in the control with a time and date stamp. The purpose of this option is only to observe the history of these reset occurrences (no changes can be made). The time is based off the Real Time Clock setting.
2. "Motor Hours": The controller shall track the accumulated hours of operation for both the upper and lower motors independently. This will be in hours to 5 places (XXXXX). This value will reset to 00000 after 99999.
- In many cases, it will match the cycle hours of the machine. However, separate fields are provided in the event that a motor is replaced on a machine.
3. "Cycle Hours": The controller shall track the accumulated hours of operation for both the upper and lower dryers independently. This information is displayed as a single value on a UI screen accessed via Manual Programming. This will be equivalent, in many cases, to the motor hours, but if a user changes a motor, the motor hours may be reset separately, and the Cycle Hours value would continue to accumulate hours. This will be in hours to 5 places (XXXXX). This value will reset to 00000 after 99999. The value displayed will round down to the nearest hour.

Usage			
Coin Vault	Revenue Since Last Reset	Amount	
	Left Amount	Amount	
	Right Amount	Amount	
	Left Input	0000 through 9999	
	Right Input	0000 through 9999	
	Display Message	On or Off	
	Reset Type	Manual or Auto	
	Reset Options	Left, Right, or Both	
	Reset History	Reset #1	
	Reset ...		
	RESET button		
Motor Hours	<i>Single</i> : 0000 through 9999	Set Motor Hours	
	<i>Stack</i> : Upper Motor Hours	0000 through 9999	Set Upper Motor Hours
	<i>Stack</i> : Lower Motor Hours	0000 through 9999	Set Lower Motor Hours
Cycle Hours	<i>Single</i> : 0000 through 9999	Set Cycle Hours	
	<i>Stack</i> : Upper Cycle Hours	0000 through 9999	Set Upper Cycle Hours

ERROR LOGS:

The last three hundred occurring error codes will be stored in the control with a time and date stamp. The purpose of this option is only to observe the history of these code occurrences (no changes can be made). Factory resets on the control do not clear the error code logs.

The time is based off the Real Time Clock. As additional error codes occur, the oldest of the three hundred logged codes is cleared from memory.

Error Logs	
Error #1	
Error ...	

FACTORY RESET:

The Factory Reset will change all adjustable parameters in the control back to factory default settings. This will create the same reset function as using the Graphics board hardware buttons. An exception to this is the Error Logs option. After the Factory Reset, the First Time Start-Up screens will be displayed, and the user will have the options to make all changes associated with these screens.

9 DISPLAYED DRYER MESSAGES

The dryer control reacts to various abnormal conditions by displaying an Error message. These messages usually contain the "Error" text, and then a general description of the message. Below is a listing of Error messages separated by each potential displayed message in bold face. Each is followed by:

- Condition that creates the displayed message on the control
- Action that the control takes responding to the condition
- Exit is the method the user (or the control) should use to bring the machine back to normal operation.

The actual displayed message on the control may contain the general description listed below and additional details (such as number or additional text). However, the condition, action or exit qualities of the error message should be the same for all variations.

OPERATION IN PROGRESS	
Condition	This error occurs when the user is attempting to start a machine operation while another operation is ending.
Action	When detected, the control does not respond to user input. There is no delay in the action once the criteria are met. The control will finish the current operation while displaying "OPERATION IN PROGRESS". Once the operation is complete, the error will no longer be displayed, and the control will respond to user input normally.
Exit	The error will be reset automatically once the current operation is complete.

POWER LOSS	
Condition	This error occurs when the Main Control Board detects a total loss of 24VAC power (usually accompanied by loss of power to the complete machine).
Action	When detected, the control turns off the motor and all other outputs. There is no delay in the action once the criteria are met.
Exit	The machine will not start, and the Error Code will continue to be displayed until the condition is no longer present. Once the condition is removed, the machine still will not start, and the Error Code will continue to be displayed for 10 seconds. After 10 seconds, the Error code should automatically reset and the cycle should be ready to re-start or the control should be in Idle mode (depending on the time period of the power loss).
BROWN OUT	
Condition	This error occurs when the Main Control Board detects less than 21VAC at the 24VAC input.
Action	When detected, the control turns off the motor and all other outputs. There is no delay in the action once the criteria are met.
Exit	The machine will not start, and the Error Code will continue to be displayed until the condition is no longer present. Once the condition is removed, the machine still will not start, and the Error Code will continue to be displayed for 10 seconds. After 10 seconds, the Error code should automatically reset and the cycle should be ready to re-start or the control should be in Idle mode (depending on the time period of the power loss).
CONTROL FIRMWARE ERROR	
Condition	This error occurs when the Main Control Board cannot command the input and outputs of the control system as required by the cycle programming.
Action	When detected, the control turns off the motor and all other outputs. There is no delay in the action once the criteria are met.
Exit	The machine will not start, and the Error Code will continue to be displayed until power is cycled to the machine, or the control is Reset to return it to Idle Mode.
TEMP SENSOR SHORT	
Condition	This error occurs when the control detects a short circuit from the temperature sensor.
Action	When detected, the dryer control shall turn off the motor and gas valve relays and the cycle time will be lost.
Exit	The dryer control shall not start until the detected short circuit is removed. Regardless of condition of short circuit, Error Code will be displayed until power is cycled to the machine, or the control is Reset to return it to Idle Mode.
TEMP SENSOR OPEN	
Condition	This error occurs when the control detects an open circuit from the temperature sensor
Action	When detected, the dryer control shall turn off the motor and gas valve relays and the cycle time will be lost.
Exit	The dryer control shall not start until the detected open circuit is removed. Regardless of condition of short circuit, Error Code will be displayed until power is cycled to the machine, or the control is Reset to return it to Idle Mode.
DRIVE ADDRESS ERROR	

Condition	This error occurs when the control detects incorrect drive address combinations from the Upper and Lower pockets drives. This error only applies for stack dryers.
Action	When the controls doesn't detect the correct drive address combinations, the control turns off the motor and all other outputs. There is no delay in the action once the criteria are met. This check is only performed upon control bootup.
Exit	The machine will not start, and the Error Code will continue to be displayed until the condition is no longer present. Once the condition is removed, the machine still will not start, and the Error Code will continue to be displayed until power is cycled to the machine, or the control is Reset to return it to Idle Mode.
CYCLE UNEXPECTEDLY STOPPED	
Condition	This error occurs when the information received from the Main Control board arrives in an unexpected order.
Action	When detected, the control turns off the motor and all other outputs. There is no delay in the action once the criteria are met.
Exit	The machine will not start, and the Error Code will continue to be displayed until power is cycled to the machine, or the control is Reset to return it to Idle Mode.
GRAPHICS SOFTWARE ERROR	
Condition	This error occurs when the Graphics Board cannot command the Main Control board as required by the cycle programming.
Action	When detected, the control turns off the motor and all other outputs. There is no delay in the action once the criteria are met.
Exit	The machine will not start, and the Error Code will continue to be displayed until power is cycled to the machine, or the control is Reset to return it to Idle Mode.
MODEL JUMPER MISSING	
Condition	This error occurs when there is no connection to Ground (Pin 8) on the Model Jumper Header.
Action	When detected, the control turns off the motor and all other outputs. There is no delay in the action once the criteria are met. The machine control checks for this condition when power is cycled and before starting every machine cycle.
Exit	The machine will not start, and the Error Code will continue to be displayed until the condition is no longer present. Once the condition is removed, the machine still will not start, and the Error Code will continue to be displayed until power is cycled to the machine, or the control is Reset to return it to Idle Mode.
MODEL JUMPER CHANGED	
Condition	This error occurs when the jumper connections to Ground (Pin 8) on the Model Jumper Header have changed since the last control check.
Action	When detected, the control turns off the motor and all other outputs. There is no delay in the action once the criteria are met. The machine control checks for this condition when power is cycled and before starting every machine cycle.
	The machine will not start, and the Error Code will continue to be displayed until the condition is no longer present. Once the condition is removed, the machine still will not start, and the Error Code will continue to be displayed until power is cycled to the machine, or the control is Reset to return it to Idle Mode.
MODEL JUMPER DRIVE SIZE MISMATCH	
Condition	This error occurs when the jumper connections to Ground (Pin 8) on the Model Jumper Header do not match the VFD size code.

Action	When detected, the control turns off the motor and all other outputs. There is no delay in the action once the criteria are met. The machine control checks for this condition when power is cycled.
Exit	The machine will not start, and the Error Code will continue to be displayed until the condition is no longer present. Once the condition is removed, the machine still will not start, and the Error Code will continue to be displayed until power is cycled to the machine, or the control is Reset to return it to Idle Mode.
MODEL JUMPER/ DRIVE PARAMETER	
Condition	This error occurs when the jumper connections to Ground (Pin 8) on the Model Jumper Header do not match the VFD parameters being used.
Action	When detected, the control turns off the motor and all other outputs. There is no delay in the action once the criteria are met. The machine control checks for this condition when power is cycled.
Exit	The machine will not start, and the Error Code will continue to be displayed until the condition is no longer present. Once the condition is removed, the machine still will not start, and the Error Code will continue to be displayed until power is cycled to the machine, or the control is Reset to return it to Idle Mode.
NON-DEXTER DRIVE	
Condition	This error occurs when a non-Dexter VFD is installed in the machine.
Action	When detected, the control turns off the motor and all other outputs. There is no delay in the action once the criteria are met. The machine control checks for this condition when power is cycled and before starting every machine cycle.
Exit	The machine will not start, and the Error Code will continue to be displayed until the condition is no longer present. Once the condition is removed, the machine still will not start, and the Error Code will continue to be displayed until power is cycled to the machine, or the control is Reset to return it to Idle Mode.
DRIVE OVERCURRENT	
Condition	This error occurs when the control receives a message that the drive has experienced an over current condition.
Action	When detected, the control turns off the motor and all other outputs. There is no delay in the action once the criteria are met.
Exit	The machine will not start, and the Error Code will continue to be displayed until the condition is no longer present. Once the condition is removed, the machine still will not start, and the Error Code will continue to be displayed until power is cycled to the machine, or the control is Reset to return it to Idle Mode.
DRIVE OVERVOLTAGE	
Condition	This error occurs when the control receives a message that the drive has experienced an over voltage condition.
Action	When detected, the control turns off the motor and all other outputs. There is no delay in the action once the criteria are met.
Exit	The machine will not start, and the Error Code will continue to be displayed until the condition is no longer present. Once the condition is removed, the machine still will not start, and the Error Code will continue to be displayed until power is cycled to the machine, or the control is Reset to return it to Idle Mode.
DRIVE OVERHEAT	
Condition	This error occurs when the control receives a message that the drive has experienced an overheat condition.

Action	When detected, the control turns off the motor and all other outputs. There is no delay in the action once the criteria are met.
Exit	The machine will not start, and the Error Code will continue to be displayed until the condition is no longer present. Once the condition is removed, the machine still will not start, and the Error Code will continue to be displayed until power is cycled to the machine, or the control is Reset to return it to Idle Mode.
DRIVE OVERLOAD	
Condition	This error occurs when the control receives a message that the drive has experienced an overload condition.
Action	When detected, the control turns off the motor and all other outputs. There is no delay in the action once the criteria are met.
	The machine will not start, and the Error Code will continue to be displayed until the condition is no longer present. Once the condition is removed, the machine still will not start, and the Error Code will continue to be displayed until power is cycled to the machine, or the control is Reset to return it to Idle Mode.
DRIVE GROUND FAULT	
Condition	This error occurs when the control receives a message that the drive has experienced a ground fault condition.
Action	When detected, the control turns off the motor and all other outputs. There is no delay in the action once the criteria are met.
	The machine will not start, and the Error Code will continue to be displayed until the condition is no longer present. Once the condition is removed, the machine still will not start, and the Error Code will continue to be displayed until power is cycled to the machine, or the control is Reset to return it to Idle Mode.
DRIVE LOW VOLTAGE	
Condition	This error occurs when the control receives a message that the drive has experienced a low voltage condition.
Action	When detected, the control turns off the motor and all other outputs. There is no delay in the action once the criteria are met.
Exit	The machine will not start, and the Error Code will continue to be displayed until the condition is no longer present. Once the condition is removed, the machine still will not start, and the Error Code will continue to be displayed until power is cycled to the machine, or the control is Reset to return it to Idle Mode.
DRIVE INTERNAL	
Condition	This error occurs when the control receives a message that the drive has experienced an internal error.
Action	When detected, the control turns off the motor and all other outputs. There is no delay in the action once the criteria are met.
Exit	The machine will not start, and the Error Code will continue to be displayed until the condition is no longer present. Once the condition is removed, the machine still will not start, and the Error Code will continue to be displayed until power is cycled to the machine, or the control is Reset to return it to Idle Mode.
DRIVE EXCEPTION	
Condition	This error occurs when the control receives a message that the drive has logged an exception code.
Action	When detected, the control turns off the motor and all other outputs. There is no delay in the action once the criteria are met.

Exit	The machine will not start, and the Error Code will continue to be displayed until the condition is no longer present. Once the condition is removed, the machine still will not start, and the Error Code will continue to be displayed until power is cycled to the machine, or the control is Reset to return it to Idle Mode.
DRIVE COMMUNICATION	
Condition	This error occurs the control cannot communicate with the VFD.
Action	When detected, the control turns off the motor and all other outputs. There is no delay in the action once the criteria are met.
Exit	The machine will not start, and the Error Code will continue to be displayed until the condition is no longer present. Once the condition is removed, the machine still will not start, and the Error Code will continue to be displayed until power is cycled to the machine, or the control is Reset to return it to Idle Mode.
DRIVE ENABLE	
Condition	This error occurs when the control sees a message that the VFD Enable circuit is not closed.
Action	When detected, the control turns off the motor and all other outputs. There is no delay in the action once the criteria are met.
Exit	The machine will not start, and the Error Code will continue to be displayed until the condition is no longer present. Once the condition is removed, the machine still will not start, and the Error Code will continue to be displayed until power is cycled to the machine, or the control is Reset to return it to Idle Mode.
OUT OF SERVICE	
Condition	This error occurs when the user has designated that the machine control should be made inoperable.
Action	When detected, the control turns off the motor and all other outputs. There is no delay in the action once the criteria are met.
Exit	The machine will not start, and the Error Code will continue to be displayed the user changes the Out of Service state.
MAX PAUSE TIME EXCEEDED	
Condition	This error occurs when a power loss or a brown out event causes an in-progress cycle to stop. If the cycle is not resumed after 1 hour, this error will be thrown.
Action	When detected, the control turns off the motor and all other outputs. There is no delay in the action once the criteria are met.
Exit	No action required. Error will be displayed for 5 seconds and then return to Idle screen.

10 SERVICING AND TROUBLESHOOTING

CAUTION: Label all wires prior to disconnection when servicing controls. Wiring errors can cause improper and dangerous operation. Verify proper operation after servicing.

ATTENTION: Lors des opérations d'entretien des commandes, étiquetez tous les fils avant de les débrancher. Des erreurs de câblage peuvent entraîner un fonctionnement inadéquat.

If any of the following symptoms occur on this dryer, check the suggested remedies listed below. If all probable causes have been eliminated and the symptom still exists, contact your local Dexter agent for further troubleshooting assistance. See contact information in Preventative Maintenance section. Parts & Service Manuals from Dexter are also available for further troubleshooting

assistance.

Symptom	Probable Cause	Suggested Remedy
Tumbler Does not turn	Control	Check that Control Display shows time available for drying. If not, deposit money as needed.
	Loading Door	Check that Loading Door is completely closed.
	Lint Compartment Door	Check that Lint Compartment Door is completely closed.
	Drive Belts	Check drive belts for excessive wear. Replace as needed.
Tumbler Turns, but no burner flame is present	Gas shut-off valve	Make sure gas shut-off valve is in the open position.
	Ignition Module	Follow the procedure for checking the ignition cycle listed in Dryer Ignition section of this manual.
Slow Drying	Control	Check that proper Temperature setting is chosen.
	Lint Screen	Clean Lint Screen.
	Air flow Restrictions/ Make-up Air	Follow installation guidelines for static back pressure and make-up air.
	Exhaust	Check exhaust for obstructions, follow installation guidelines.
"Temp Sensor Short" or "Temp Sensor Open" Error Code displayed on control	Temperature Sensor	Check to confirm Temp Sensor wiring, and then cycle power to dryer to clear Error Code. If Error Code persists, contact Dexter agent for assistance.

11 PREVENTIVE MAINTENANCE INSTRUCTIONS

DAILY

1. Clean the lint screen. Use a soft brush if necessary.
2. Check the lint screen for tears. Replace if necessary.
3. Clean lint from the lint screen compartment.
4. Inspect felt seal on lint screen assembly. Replace if necessary.

MONTHLY

1. Remove lint accumulation from the end bells of the motors.
2. Remove lint accumulation from front control area.
3. Remove lint and dirt accumulation from the top of the dryer and all areas above, below, and around the burners and burner housing. Failure to keep this portion of the dryer clean can lead to a build-up of lint creating a fire hazard.

QUARTERLY

1. Check the belts for looseness, wear, or fraying.
2. Inspect the gasket of the door glass for excessive wear.
3. Check tightness of all fasteners holding parts to support channel.
4. Check tightness of all set screws.
5. Inspect the impeller for tightness of the blades to hub.
6. Remove the air flow switch assembly and check the tumbler thru-bolts for tightness.
7. Grease the pivot pins and the tension arms where in contact with each other. (Where applicable)

SEMI-ANNUALLY

1. Remove and clean the main burners.
2. Remove all orifices and examine for dirt and hole obstruction.
3. Remove all lint accumulation. Remove the front panel and the lint screen housing and remove lint accumulation.
4. Apply a few drops of oil to each spacer tube on the tension arm assembly. (Where applicable)

ANNUALLY

1. Check the intermediate pulley bearings for wear.
2. Check and remove any lint accumulation from the exhaust system.
3. Grease the bearings and the shaft of the intermediate drive pulley. Use an Alemite grease gun and Molykote BR2-S grease. (Where applicable)

SERVICE PARTS

PART NUMBER

	T-30X2	T-30X2 REV	T-50X2	T-50X2 REV
DRIVE BELT, MOTOR	9040-077-001	N/A	9040-076-009	N/A
DRIVE BELT, TUMBLER	9040-073-009	9040-073-004	9040-073-011	9040-076-003
LINT SCREEN FILTER	9555-057-002	9555-057-002	9555-057-008	9555-057-008

For service and parts information, contact your local Dexter agent. To find your local Dexter agent, use the Distributor Locator at the website shown below. If a Dexter agent is not available, contact **Dexter Laundry, Inc.** directly as listed below:

Mailing Address: 2211 West Grimes Avenue Phone: 1-800-524-2954
Fairfield, IA 52556
USA

Website: www.dexter.com

12 Instructions - Convert a Dual Voltage Stack Dryer

From 120V to 208-240V (No Neutral Required, Only for -15 Models)

1. Remove incoming power from the dryer. Use a known working voltmeter to check power.
2. Remove the cover of the control box assembly from the dryer using a 5/16" wrench.
3. Move all black/orange wires from the N position of the main power terminal block to the L2 position of the main power terminal block in the upper control box assembly. See figure below.
4. Move the white/red wire of the upper motor harness to an upper inner left terminal in the middle terminal block in the lower control box assembly. See figure below.
5. Move the orange wire of the upper motor harness to an upper inner left terminal in the middle terminal block in the lower control box assembly. See figure below.
6. Move the white/red wire of the lower motor harness to a lower inner left terminal in the middle terminal block in the lower control box assembly. See figure below.
7. Move the orange wire of the lower motor harness to a lower inner left terminal in the middle terminal block in the lower control box assembly. See figure below.

Conversion instructions continued on next page.

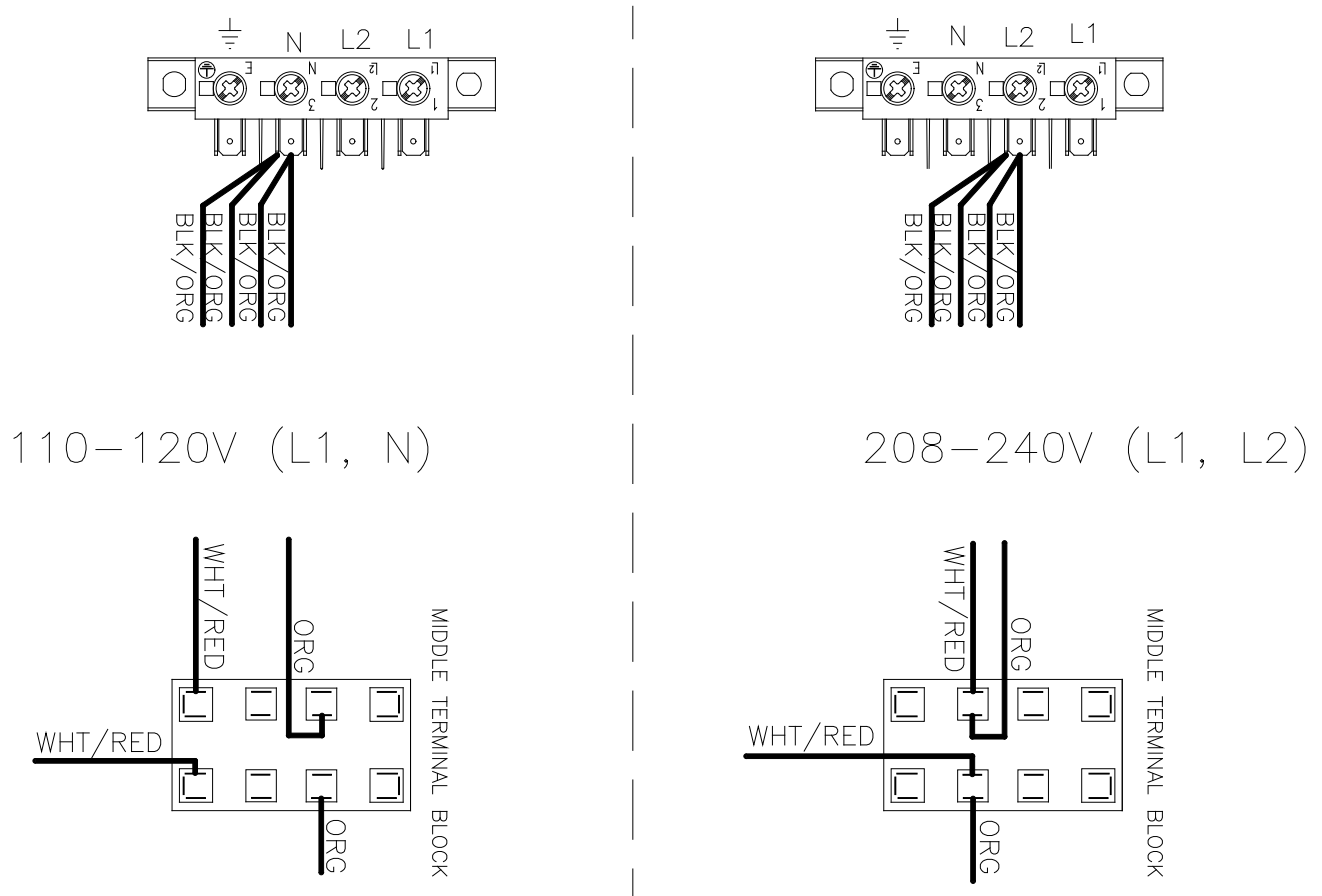

8. Move the black/brown wire from the 120V tap on the transformer found in the bottom of control box to the required voltage tap based on actual supply voltage measurement. See figure below.

CONTROL TRANSFORMER CONNECTIONS AS VIEWED FROM SIDE OF TRANSFORMER

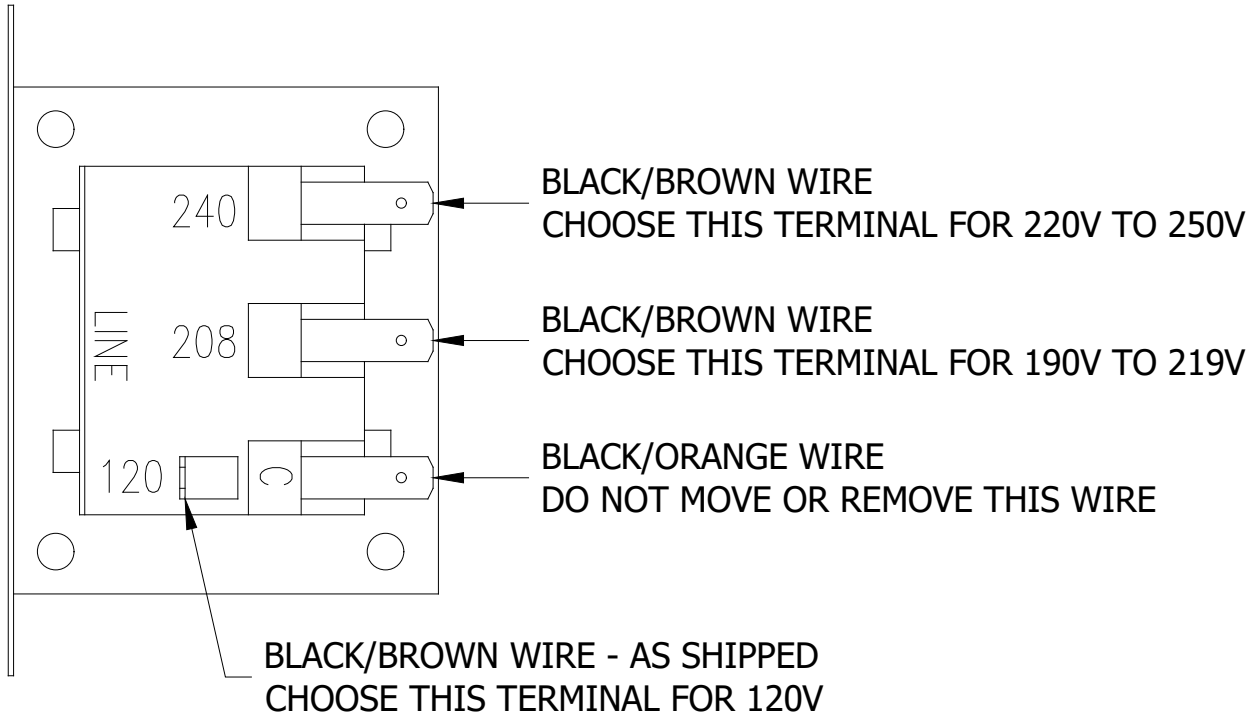

9. Reconnect power to the dryer and test to ensure proper operation; one line voltage to L1, one line voltage to L2 and the earth ground to E.
10. Reinstall the cover of the control box assembly on the dryer using a 5/16" wrench.