



DEXTER[®]
LAUNDRY

**USE THE BLUE TABS LOCATED ON THE
RIGHT AND LEFT SIDES OF THE FOLLOWING
DOCUMENT TO ADVANCE TO EACH SECTION.**

C-Series Accessories

WC1800-XA12ECX 208-240 volts 60hz Single Phase or Three Phase

Key	Description	T-1800	QTY
*	Hose, Water Supply 3/8" I.D. x 48"	9990-027-011	2
*	Hose, Water Supply 5/8" I.D. x 48"	9990-027-013	2
*	Washer, Inlet Hose (furnished)	8641-242-000	2
*	Strainer, Inlet Hose (furnished)	9565-003-001	2
*	Bevel Washer for 5/8" bolt used in installations using angle iron bases	8641-586-002	
*	Bevel Washer for 3/4" bolt used in installations using angle iron bases	8641-586-003	4
*	Sealing compound	8538-151-001	1
*	TORX#20	8545-051-002	1
*	Special Tool For Removing Coin Acceptor Mounting Screws. (T-10 Torx)	8545-051-003	1
*	Flow Restrictors (in dispenser)	9475-002-003	2
*	Battery (used on Control PCB)	8612-001-001	1
*	Special Tool for adjusting spacing between outer tub front and cylinder front	8545-056-001	1
*	Clamps to hold tub front to outer tub when installing tub front	Vise Grip #11R	1
*	Coin Bearing & Seal Kit	9732-219-009	1
	Key Service Lock (6324)	6292-006-007	1
	USB, Thumb Drive (Blank)	9150-045-001	1
	USB, Thumb Drive, W/File	9150-045-002	1
*	Mode Light Support	9635-022-001	1
*	MS300 Display	9150-058-001	1



Section 8: Parts Data C-Series Vended Large Chassis

WC1800XA-12EC4X

After Serial # W1.21

Kits, Assemblies, & Common Parts

Description	T-1800
Optical Coin Switch	9801-099-001
Kit - Door Lock Assy. & Cam, replaces 9885-024-001	9732-347-001
Kit - Door cam replacement	9732-346-002
Kit - Locking Pawl replacement	9732-346-001
Coin Acceptor switch kit w/ extra actuator	9732-126-001
Kit - 3" Drain valve seal replacement	9732-327-001
Drain Valve 3"	9379-202-001
Drain Valve 2"	9379-199-001
Water Valve (Dual)	9379-183-012
Water Valve (Single)	9379-194-001
Diaphragm	9118-049-003
Cylinder Plug (1.5" Plastic)	9456-041-007
Electronic Pressure Switch	9732-315-001
Delta E Drive Display	9150-044-001
Breaking Resistor 160 Ohms	9483-004-003
Breaking Resistor 200 Ohms	9483-004-002
Transformer, Main	8711-004-001
Transformer, Control	8711-009-001
Main Control Board	9473-010-001
Data Cable (56")	9806-015-003
Door Lock Gear Motor Assembly	9922-015-001
Door Lock Latching Assembly	9885-024-001
Door Handle Only	9244-091-001
Door Switch	9539-492-001
Electrical Coin Acceptor	9021-077-001
Coin Drop Screws	9545-053-002
Retainer Coin Acceptor	9486-149-001
Front Panel Screw	9545-008-014
Front Panel Finisher Washer	8641-585-001
Front Panel Spring Nut	8640-399-008
Soap Box Screw	9545-008-012
Soap Box Spring Nut	8640-399-007
5/16 Hex Screw	9545-008-026
Belt	9040-079-006
Top Lock Key #6324	9306-025-001
Door Glass Gasket	9206-431-001
MS 300 VFD Display	9150-058-001

Wiring Harness Part # by Model

Key	Description	T-1800	QTY
*	Wiring Harness, Door Lock	9627-791-007	1
*	Wiring Harness, Coin Drop Mech	9627-792-001	1
*	Wiring Harness, Drain, Thermo, Door Sol	9627-796-002	1
*	Data Cable	9806-025-003	1
*	Wiring Harness P20/P21	9627-793-001	1
*	Wiring Harness P8/P16	9627-794-001	1
*	Wiring Harness Water Valve/P19	9627-795-005	1
*	Wiring Harness LED PCB	9627-797-001	1
*	Wiring Harness P5/pressure	9627-908-013	1
*	Wiring Assembly Yel. 50"	8220-064-060	2
*	Wiring Assembly Red 7" #36	9631-381-018	3
*	Wiring Assembly Blk/Blu	8220-001-231	1
*	Harness Power Terminal Block	9627-747-005	1
*	Wire Yellow Jumper (water valve)	8220-119-002	1
*	Cable Assembly, USB	9806-022-001	1
*	Wiring Assembly Blk/Red, 8.5"	8220-001-030	1

Cabinet and Front Panel Group Part # by Model

Key	Description	T-1800	QTY
1	Panel, Side (Left or Right) - stainless	9444-028-001	4
*	Strap Assembly (side panel)	9966-012-001	2
*	Shim (side panel)	9552-050-001	2
*	Nut, Hex 1/4-20 UNC (for strap assembly)	8641-414-006	8
2	Bracket, Side Panel under front panel	9046-086-001	1
•	Nut, Hex	8640-414-006	2
*	Screw	9545-008-026	2
5	Panel Assy, Front	9444-054-001	1
*	Band, Edge Protector	9578-092-005	1
6	Bumper Loading Door	9051-055-001	1
*	Nut, 1/4 x 20 for bumper	8640-414-003	1
*	Screw, Hex- To Control Panel	9545-008-026	2
*	Nut, Spring- To Control Panel 10/32	8640-442-001	2
7	Screw, Flat Head- Front to Sides	9545-008-014	4
8	Washer, Finish	8641-585-001	4
*	Nut, Spring-To Front Panel	8640-442-001	2
9	Label-Door Opening (Blue)	8502-757-002	1
9	Label-Door Opening (Black)	8502-757-001	1
10	Label-Risk of Injury (Blue)	8502-759-002	1
10	Label-Risk of Injury (Black)	8502-759-001	1
11	Panel, Control (Mounts Nameplate)	9989-561-001	1
*	Screw, Control Panel to Sides	9545-008-026	4
12	Nameplate Decal, Control Blue	9412-261-002	1
12	Nameplate Decal, Control Black	9412-261-001	1
14A	Panel Top Front	9444-029-001	1
14B	Panel Top Rear	9444-030-001	1
15	Lock, Top (w/Key)	8650-012-003	2
*	Key, Top- # 6324	6292-006-007	1
*	Cam, Lock-Top	9095-049-001	1
*	Nut, 9/32 - 28 Hex	8640-426-001	1
*	Washer Flat 5/16	8641-581-008	1
16	Door, Lower Service, Includes Handle	9960-286-005	1

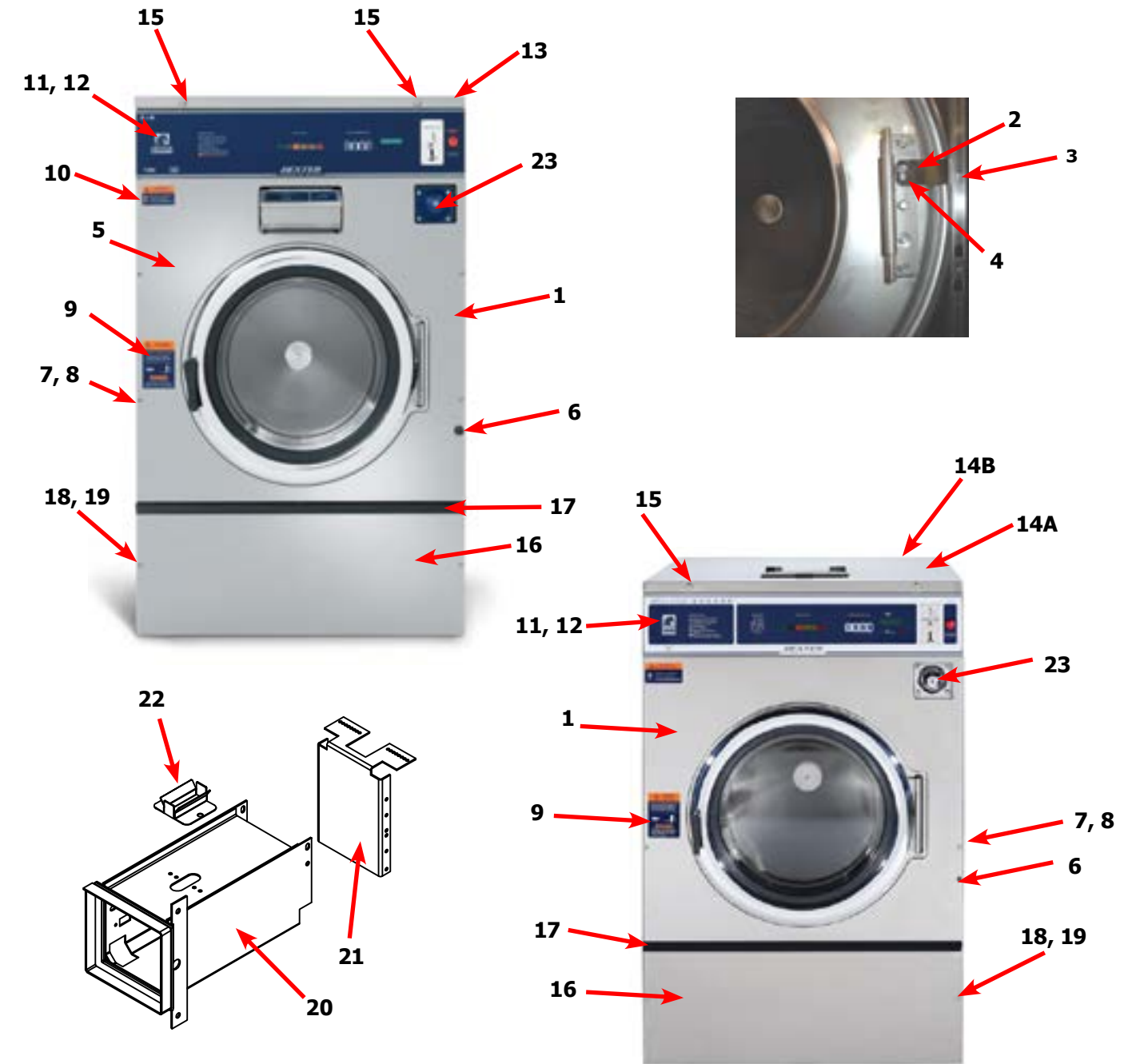

Key	Description	T-1800	QTY
17	Handle (bumper guard)	9244-086-004	1
*	Rivet Blind 3/16" Alum	9491-009-003	4
*	Screw	9545-008-023	4
18	Screw Mtg., Flat Head 10Bx1 3/4	9545-008-014	2
19	Washer, Finish	8641-585-001	2
*	Nut, Spring	8640-442-001	2
20	Coin Vault, Black	9942-040-002	1
21	Back-Coin Vault	9050-066-001	1
*	Screw, 10B x 1/2	9545-008-026	8
22	Chute, Coin	9119-032-001	1
*	Screw, Coin Schute	9545-008-001	2
23	Coin Box assy, Large Blue	9807-099-002	1
23	Coin Box assy, Large Black	9807-099-004	1

Cabinet and Front Panel Group Part # by Model Front Soap Dish

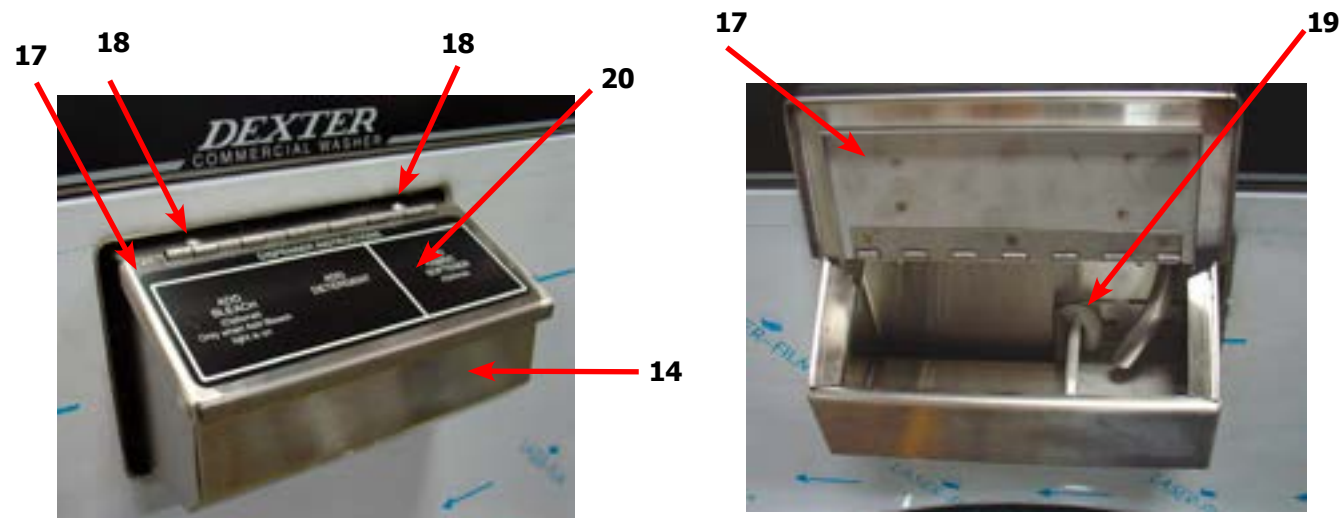
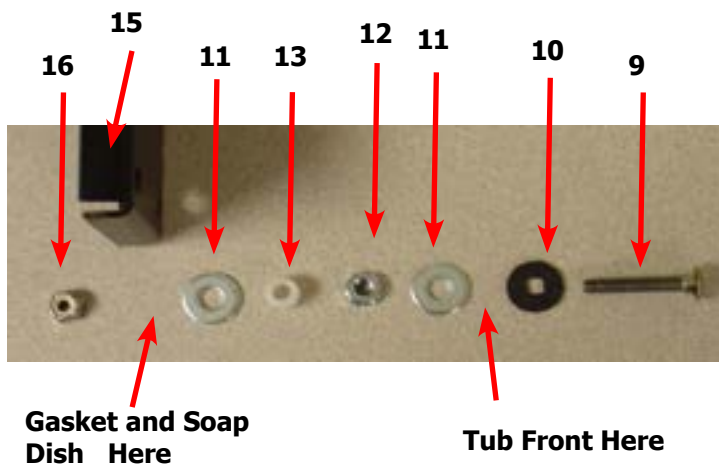

Key	Description	T-1800	QTY
*	Washer Flat 5/16	8641-581-008	1
7	Screw, Locator	9545-008-023	1
8	Plastic Sleeve, Locator	9355-001-001	1
*	Catch, Top Panel	9086-017-001	2
*	Lock, Top (w/Key)	8650-012-003	2

Front Mount Detergent Dispenser

Key	Description	T-1800	QTY
9	Bolt, #10-32 x 1 1/4"SS	9545-012-026	6
10	Special Washer, Rubber	8641-222-000	6
*	Tub Front	9974-020-001	1
11	Washer-Flat, 1/4	8641-581-018	12
12	Nut, #10-32UNF	8640-413-004	6
13	Spacer Plastic #10x1/2	9538-157-026	6
14	Soap Dispenser (no lid)	9807-087-001	1
*	Det. Dispenser Mtg Gasket to Tub frnt	9206-425-001	1
15	Bracket Soap box mounting	9029-122-002	1
16	Nut Hex Elasticstop #10-32 SS mtg dispenser	8640-413-006	6
17	Lid Assembly dispenser	9987-104-001	1
18	Lid screws #10-32x1/2 SS	9545-012-017	2
19	Softner siphon tube (plastic)	9574-252-002	1
*	Flow restrictors	9475-002-003	AR
20	Washer Dispenser Label Blue	8502-756-002	1
20	Washer Dispenser Label Black	8502-756-001	1

Rear View Access Part # by Model

Key	Description	T-1800	QTY
1	Drive Motor, 3 Phase	9376-328-001	1
2	Rod, Motor Mtg	9497-222-004	1
3	Motor-Bushing, Support	9053-074-002	2
4	Clamp for motor bushing	8654-117-019	2
5	Pulley, Motor	9453-175-002	1
5	Split TaperBushing (motor pulley)	9053-077-001	2
*	Screw taper bushing 1/4-20x1	9545-018-024	3
6	Bolt, Eye (1/4"-20x1/2")	9545-055-001	1
*	Nut, 1/4 Elastic Stop	8640-414-003	1
*	Link (open end)	9341-046-001	1
7	Chain (Spring Tension)	9099-012-004	1
8	Spring, Belt Tension	9534-151-000	1
9	Pulley, Driven	9453-176-006	1
10	Washer-Flat .675x2-1/2x1/4	8641-581-044	1
11	Lockwasher-Exttooth, 5/8	8641-582-020	1
12	Bolt, 3/4-11x1 1/2	9545-057-004	1
13	Bushing Taperlock (Pulley)	9053-078-002	1
14	Bolt, 3/8"-16 x 2"	9545-029-011	3
15	Washer, 3/8"	8641-582-003	3
16	Drive Belt	9040-079-006	1
17	Hose, Overflow to drain	9242-449-005	1
*	Clamp, Hose overflow to drain	8654-117-018	2
18	Hose, Overflow Vent Top	9242-463-006	1
*	Clamp, Hose Vent	8654-117-008	1
*	Vaccum Breaker ALL	9610-001-001	1
*	Clamp, Hose to Vacuum Breaker	8654-117-014	2
19	Hose, Vacuum Breaker to tub	9242-458-003	1
*	Vaccum Breaker Bracket	9029-266-001	1
20	Hose, Pressure Switch	9242-175-003	1
*	Clamp, Pressure Switch Hose	8654-117-015	1
21	Channel, Rear,	9947-055-001	1
22	Screw #10Bx1/2	9545-008-026	4
*	Nut, Spring	8640-442-001	4
23	Cover, Terminal Block	9074-267-001	1
*	Screw #10Bx1/2	9545-008-026	1

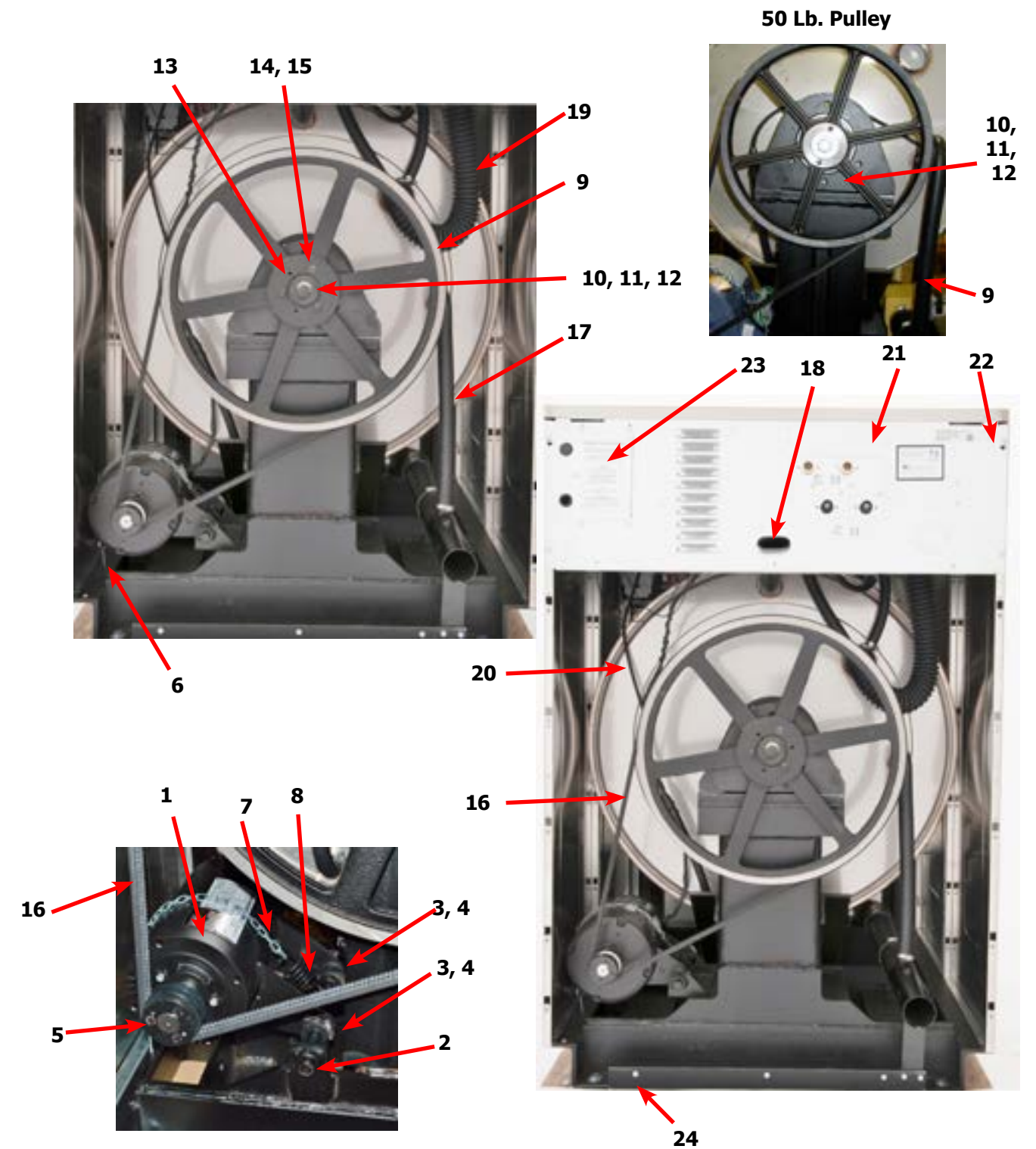

Key	Description	T-1800	QTY
*	Panel Assy., Back, Upper	9454-873-001	1
*	Panel Assy., Back, Lower	9989-872-001	1
*	Screw Panel Mtg.#10Bx1/2"	9545-008-026	13
*	Nut, Spring	8640-442-001	AR
28	Screw, To Base-1/4" x 3/4"	9545-030-002	3

Cylinder, Seals & Bearings Part # by Model

Key	Description	T-1800	QTY
*	Bearings and Seal Kit	9732-219-009	1
*	Housing, Bearing- Assembly (items #2-#6)	9803-209-001	1
2	Housing, Bearing	9241-195-003	1
3	Bearing, Front (Small)	9036-162-002	1
4	Bearing, Rear (Large)	9036-162-001	1
5	Spacer, Bearing	9538-185-001	1
6	Ring, Bearing Retainer	9487-238-004	1
8	Seal, Small V95A	9532-140-012	1
9	Seal, Large V140A	9532-140-008	1
10	Ring, Seal Mounting	9950-062-001	1
11	Tub Back Mating Ring	9487-261-005	1
11G	Mating Ring Guard Shield	9487-276-001	1
12	Bolt, Tub End of Bearing Housing (7/16-14x1), Bolt from inside Tub	9545-059-004	6
13	Washer, Flat	8641-581-034	6
14	Screw-Hex Cap, 7/8"-9 x 3 1/2" (Bearing Housing to Frame)	9545-066-001	6
15	Washers Spherical 7/8" (Male half) (Bearing Housing to Frame)	8641-588-003	6
16	Washers Spherical 7/8" (Female half) (Bearing Housing to Frame)	8641-588-004	6
17	Nut 7/8"-9 (Bearing Housing to Frame)	8640-437-001	6
18	Pulley, Driven	9453-176-006	1
19	Bolt, 3/8"-16 x 2"	9545-029-011	3
20	Washer, 3/8"	8641-582-003	3
21	Bushing Taperlock (Driven & Large)	9053-078-002	1
22	Washer-Flat .675x2-1/2x1/4	8641-581-044	1
23	Lockwasher-Exttooth, 3/4	8641-582-020	1
24	Bolt, 3/4-10x1 1/2	9545-057-004	1
25	Tub & Cylinder Assy	9869-046-001	1
*	Cylinder Assy	9848-170-001	1
*	Tub Front	9974-012-001	1
*	Gasket, Tub Front	9206-421-003	1
*	Ring Assy, Tub Mtg-Front Clamp	9950-061-001	1
*	Bolt, Top Front Ring 3/8"-16 x 3"	9545-029-009	1
*	Nut C Series 3/8"-16	8640-415-001	1

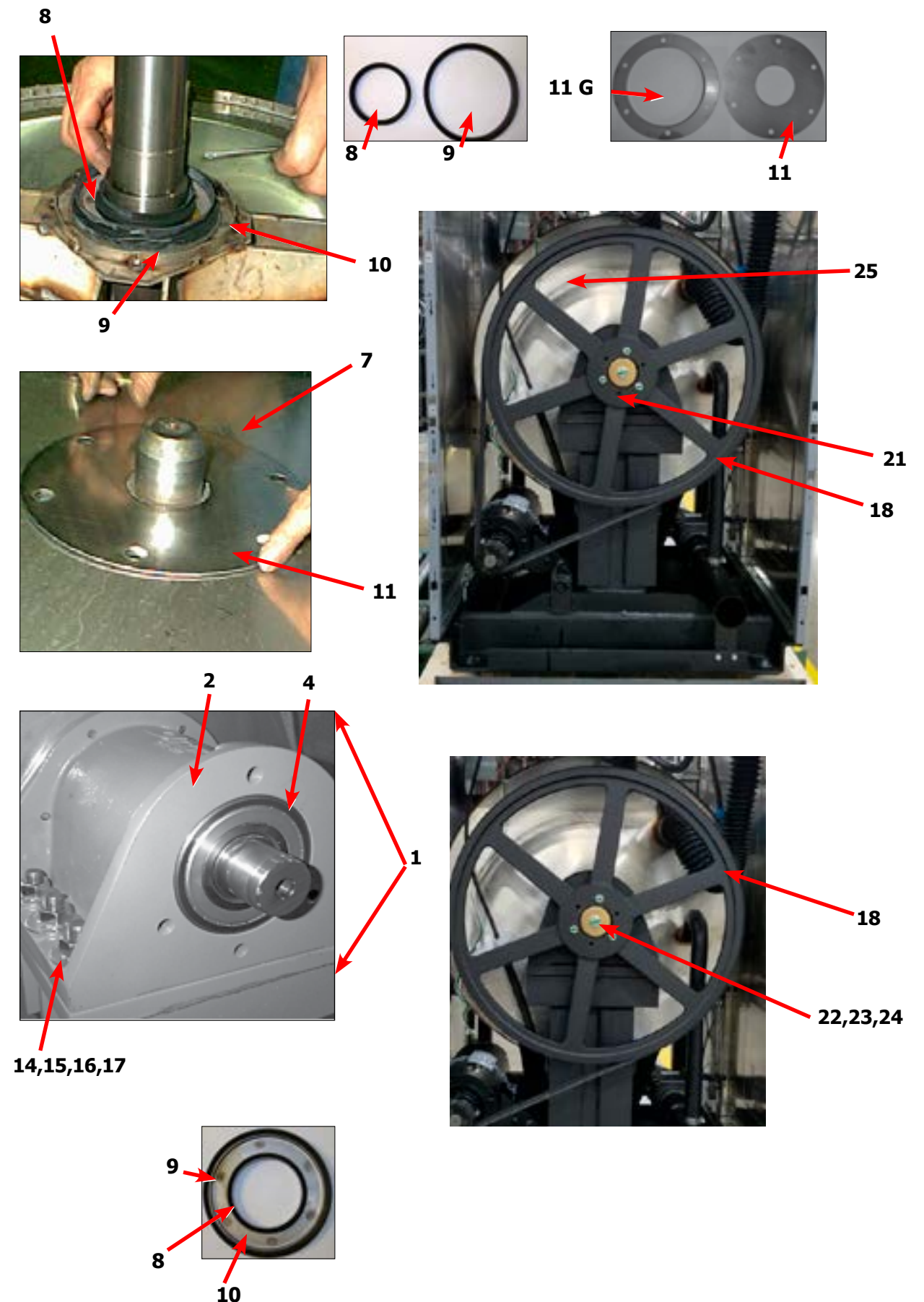

Door Lock Assembly (All Models)

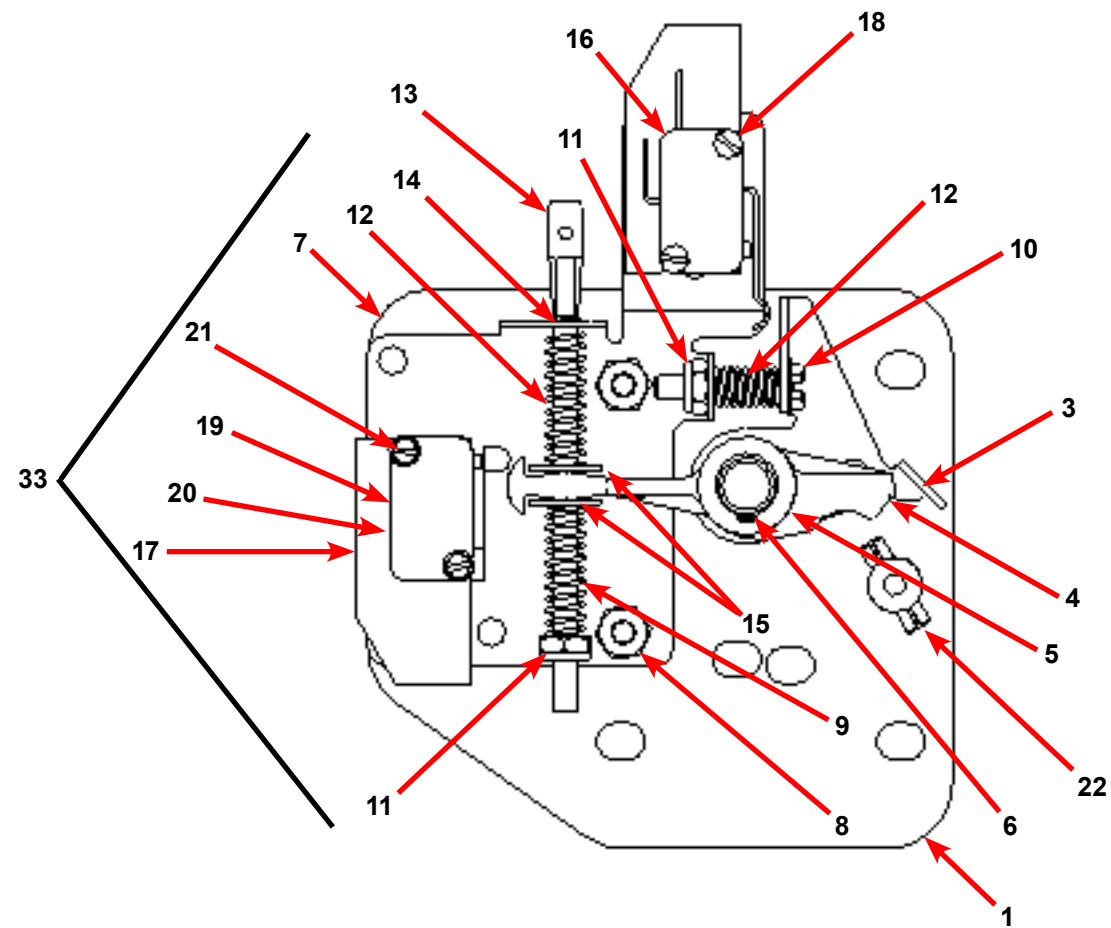

Key	Description	All Models	QTY
33	Lock Assy, Complete (#1-22) (includes #1 thru #22)	9885-024-001	1
1	Plate Assy, Door Lock	9982-346-001	1
2	Washer, Flat (SS or Brass)	8641-581-030	1
3	Actuator, Latching Switch	9008-005-001	1
4	Pawl, Locking	9732-346-002	1
5	Washer, Spring	8641-569-003	1
6	Ring, Retaining	9487-200-004	1
7	Bracket Switch	9029-163-001	1
8	Nut, Hex 10-32 UNF	8640-413-002	2
9	Spring, Actuating	9534-364-002	1
10	Screw, Hx. 10-32 x 1"	9545-012-020	1
11	Nut, Elastic Stop 10-32	8640-413-004	2
12	Spring, Return	9534-364-001	2
13	Pin, Guide	9451-193-001	1

Key	Description	All Models	QTY
14	Ring, Retaining	9487-200-005	1
15	Washer	8641-581-031	1
16	Switch, Latching Sensing	9539-461-008	1
17	Shield, Switch	9550-169-003	3
18	Screw 4-40 x 5/8"	9545-020-001	2
18	Nut, Twin 4-40	8640-401-001	1
19	Switch, Locking Sensing	9539-461-007	2
20	Actuator, Switch Locking	9008-006-003	1
21	Screw 4-40 x 1 1/8"	9545-020-003	2
21	Nut, Twin 4-40	8640-401-001	1
*	Spacer Sensor	9538-182-001	*
22	Pin, Dowel (for door cam)	9451-193-001	1
*	Shim, Door Lock, Thin	9552-037-001	AR
*	Screw, Lock mtg 1/4"-20 x 3/4"	9545-018-014	3
*	Lockwasher 1/4" Ext tooth	8641-582-007	3
*	Door Pin Stud, 3/16" x 3/4"	9451-181-004	1

Gear Motor Door Lock Assembly

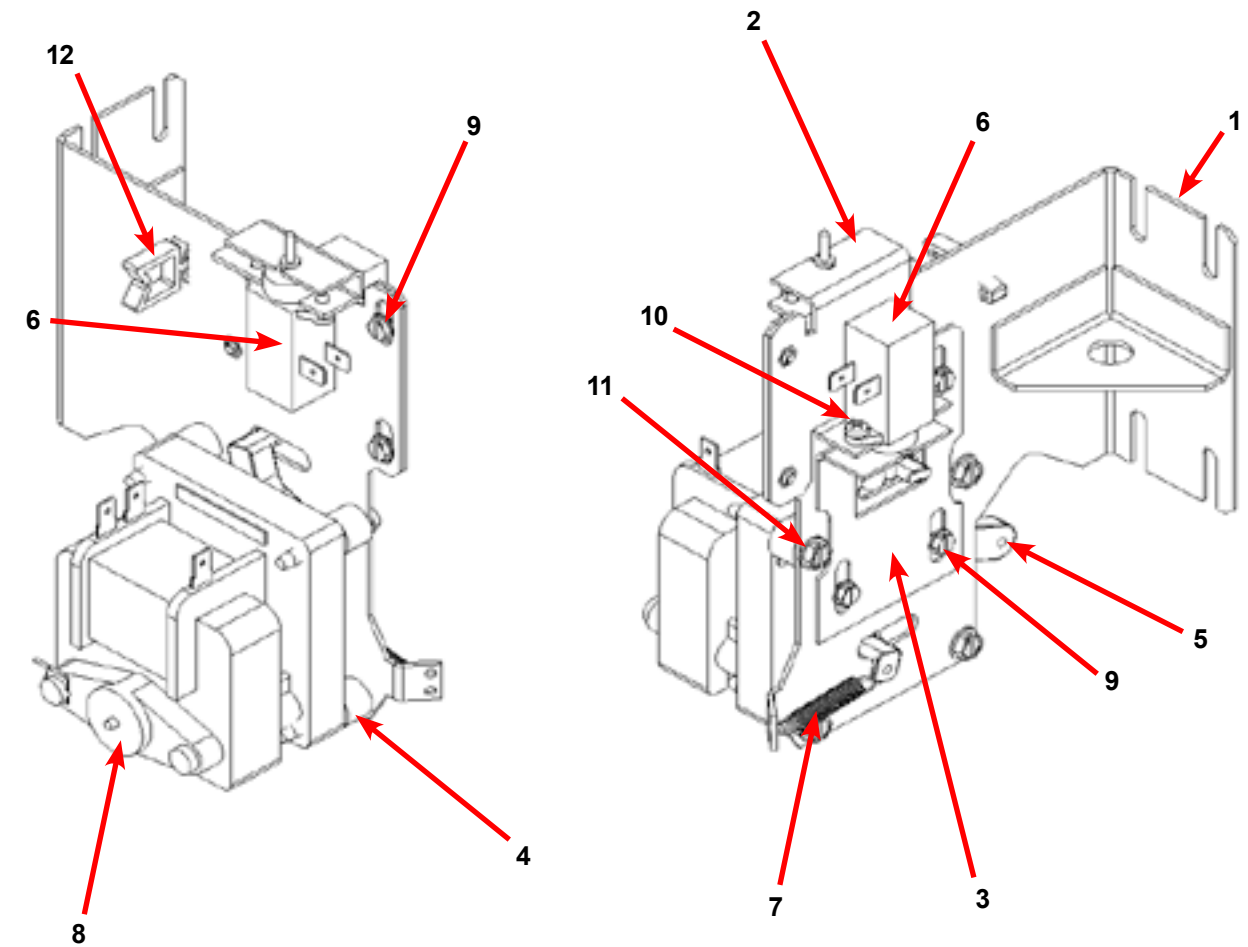

Key	Description	T-1800	QTY
*	Actuator Assembly (Includes 1-10, Rod NOT included)	9892-015-001	1
1	Bracket Assy, Slide Lock Actuator	9985-190-001	1
2	Bracket Assy, Slide - Unlock	9985-189-001	1
3	Bracket Slide Lock	9029-204-001	1
4	Spacer, Plastic	9538-157-021	4
5	Arm - Door Lock	9001-063-001	1
6	Thermoactuator - Door Lock Relay 120v	9586-001-001	2
7	Spring - Extension	9534-350-001	1
8	Motor & Gear Assembly 120v	9914-137-015	1
9	Screw -Hxwshrdslsems, 6-32 x 3/16	9545-044-003	6
10	Cross Recessed PAn Hd Tapping screw	9545-031-011	4
11	Screw hxwshdsl, 10-24 - 1.25f, ctd	9545-046-007	4
12	Standoff-Wire	9527-007-001	1
*	Rod, Door Lock	9497-225-016	1
*	Harness, Door Lock/Drain, P17	9627-791-007	1

Large Door & Hinge Group

Key	Description	T-1800	QTY
1	Door Hinge Assembly (mounts to tub front)	9955-031-001	1
*	Door Assembly Complete	9960-310-001	1
2	Door Ring 180 degree large hnge	9487-275-001	1
3	Door Gasket	9206-431-001	1
4	Door Glass Window	9635-020-001	1
*	Red Wire (Door Close Switch)	8220-063-036	1
*	Black Wire (Door Close Switch)	8220-063-037	1
5	Switch, Door Hinge Close (Plunger)	9539-492-001	1
6	Top Door Hinge Leaf	9845-006-001	1
7	Bottom Door Hinge Leaf	9845-007-001	1
8	Thrd Form Screw, Door Mtg 5/16" x 5/8"	9545-056-002	4
9	Screw, Loading Door Hinge Mtg (5/16" x9/16" ss)	9545-014-009	3
9	Washer, Star 5/16	9913-134-003	3
10	Bracket Retainer support side panel	9046-085-001	1
*	Shim Large door	9552-043-001	1

Key	Description	T-1800	QTY
*	Shaft Assembly-Loading Door (11-14)	9913-136-001	1
11	Shaft, Door Locking	9537-195-002	1
12	Cam, Locking	9095-051-001	1
13	Pin, Groove (1 1/4)	9451-181-005	1
14	Pin, Groove (3/4)	9451-181-004	1
15	Spring, Lock Cam	9534-360-002	1
16	Handle, Door	9244-091-001	1
17	Pin, Door Handle (groove)	9451-181-005	1
18	Trim, Edge	9578-092-002	1

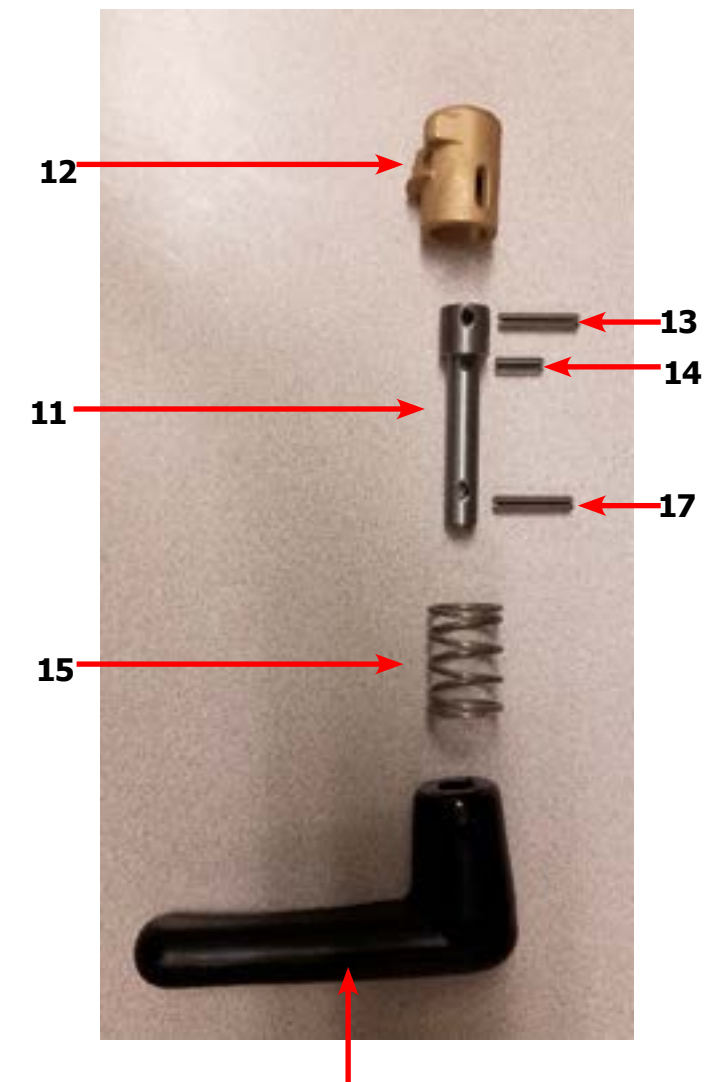
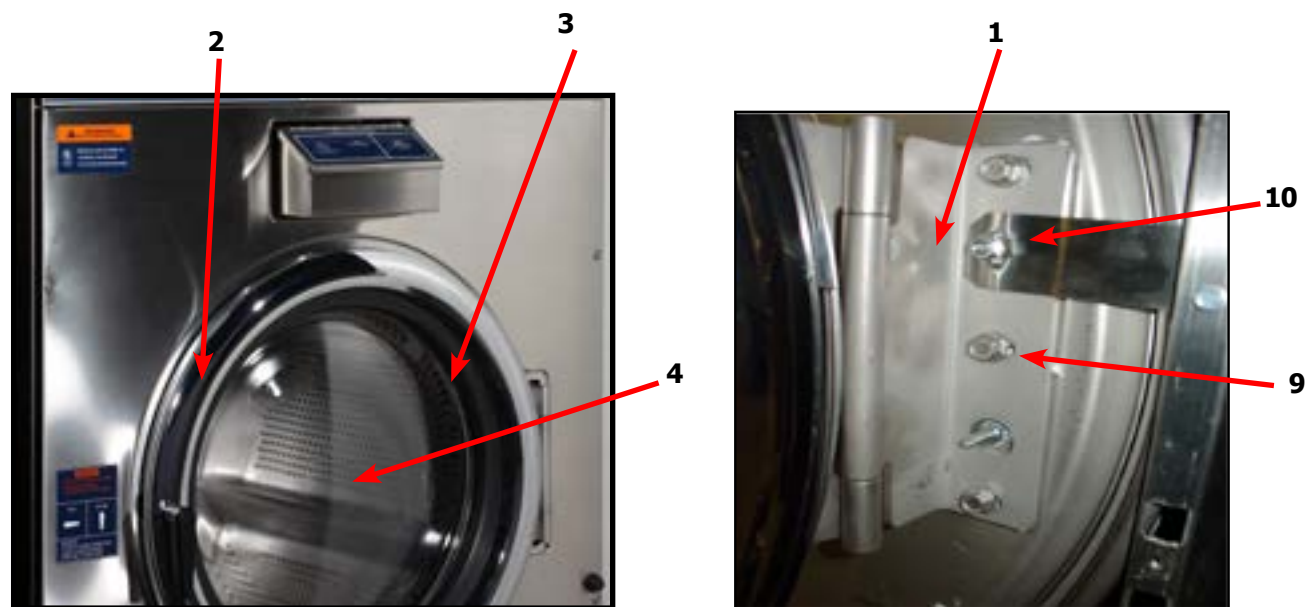

Water Inlet & Rear Channel

Key	Description	T-1800	QTY
1	Channel Assembly, Rear	9497-029-001	1
*	Screw, #10B x 1/2	9545-008-026	4
*	Clip, Spring	8640-442-001	4
2	Mounting Plate Water Valves	9452-814-001	1
3	Nut-Elastic stop, #10-32	8640-413-002	2
4	Valve, Water Inlet (dual outlet) (see Water Inlet Valve Breakdown for individual parts)	9379-183-012	2
5	Screw, Valve Mtg	9545-008-026	4
8	Valve, Water Inlet (Single outlet) (see Water Inlet Valve Breakdown for individual parts)	9379-194-001	2
*	Screw, M4x0 7 x 8mm	9545-064-001	4
*	Wire-Assy, Jumper, Yellow	8220-119-002	1
9	Shield over Water Valves Plastic	9550-195-001	1
10	Push Clip	9083-121-001	3
11	Vacuum Breaker	9610-001-001	1
12	Vacuum Breaker Cap (Red)	0935-135-002	3
*	Bracket, Vacuum Breaker	9029-266-001	1
13	Screw, #10B x 1/2	9545-008-026	4
*	Clamp, Hose to Vacuum Breaker	8654-117-014	1
*	Hose, Vacuum Breaker to Tub	9242-458-003	1
*	Clamp, Tub End	8654-117-009	1
*	Hose, overflow Suds	9242-463-006	4
*	Clamp, Hose-Spring (overflow to tub back)	8654-117-018	2
14	Plate Assembly, Drive Mounting	9452-858-001	1
15	Nut-#10-32UNF, 2B	8640-413-002	4
16	VFD Delta drive 208-240 volt	9375-039-002	1
*	VFD Cooling Fan	9189-016-001	1
*	Wire assy Brown, 3"	8220-057-035	1
*	Wire assy Red, 3"	8220-057-036	1
*	Key Pad-Display Delta Drive	9150-058-001	1
*	Cable-Data, Communication	9806-025-003	1
17	Bushing, 7/8	9053-067-002	1
18	Plug, 7/8	9545-041-006	1
19	Bracket, Terminal-Mounting	9029-326-001	1
20	Screw, #10B x 1/2	9545-008-026	4
21	Label-Warning	8502-639-001	1
22	Strip-Terminal Marker	9558-025-001	1
23	Terminal Block	9897-033-002	1
24	Screw-Phillips, 6ABx3/4	9545-031-010	2
25	Harness-Power, Terminal Block	9627-747-005	1
26	Bushing, 1"	9053-067-004	1
27	Terminal Lug, Solderless	8652-134-001	1
28	Lock-Washer Extooth #10	8641-582-006	1
29	Screw, #10-32 TTX 1/2 GRN	9545-008-027	1

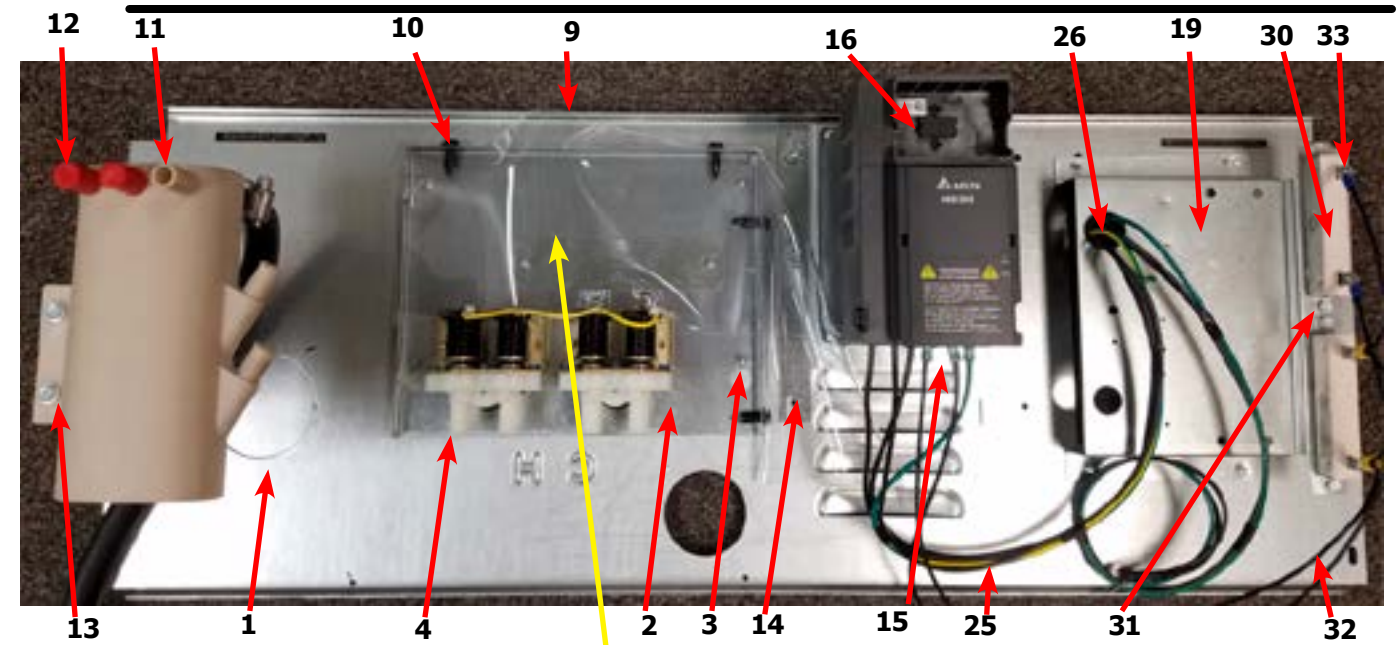

T-1200 Single coil water valve

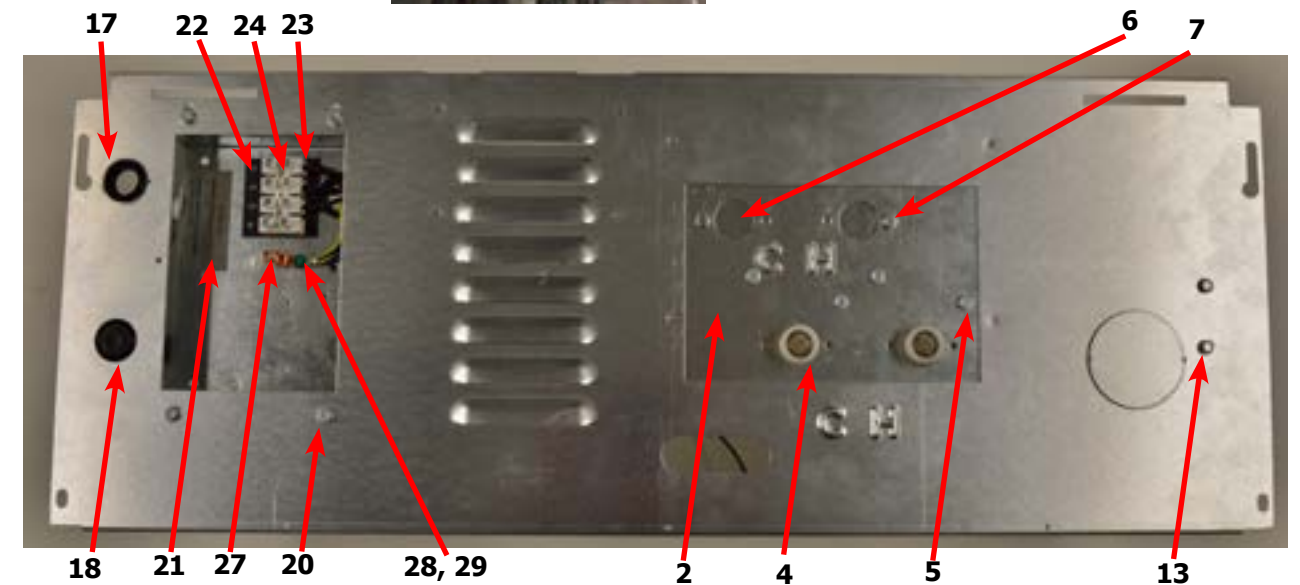
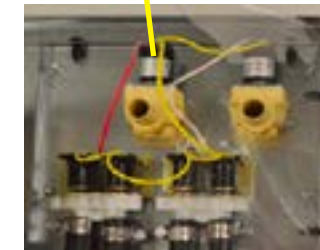

Key	Description	T-1800	QTY
30	Braking resistors (200 ohm)	9483-004-003	2
31	Screw-#10Bx1/2	9545-008-026	4
32	Wire Assy, Jumper	8220-117-003	2
33	Screw, #6-32x5/16	9545-044-006	4
33	Nut, #6-32	8640-411-003	4
*	Cover Controls	9074-267-001	1
*	Screw-#10Bx1/2	9545-008-026	1
*	Label-Warning, Notice	8502-761-001	1

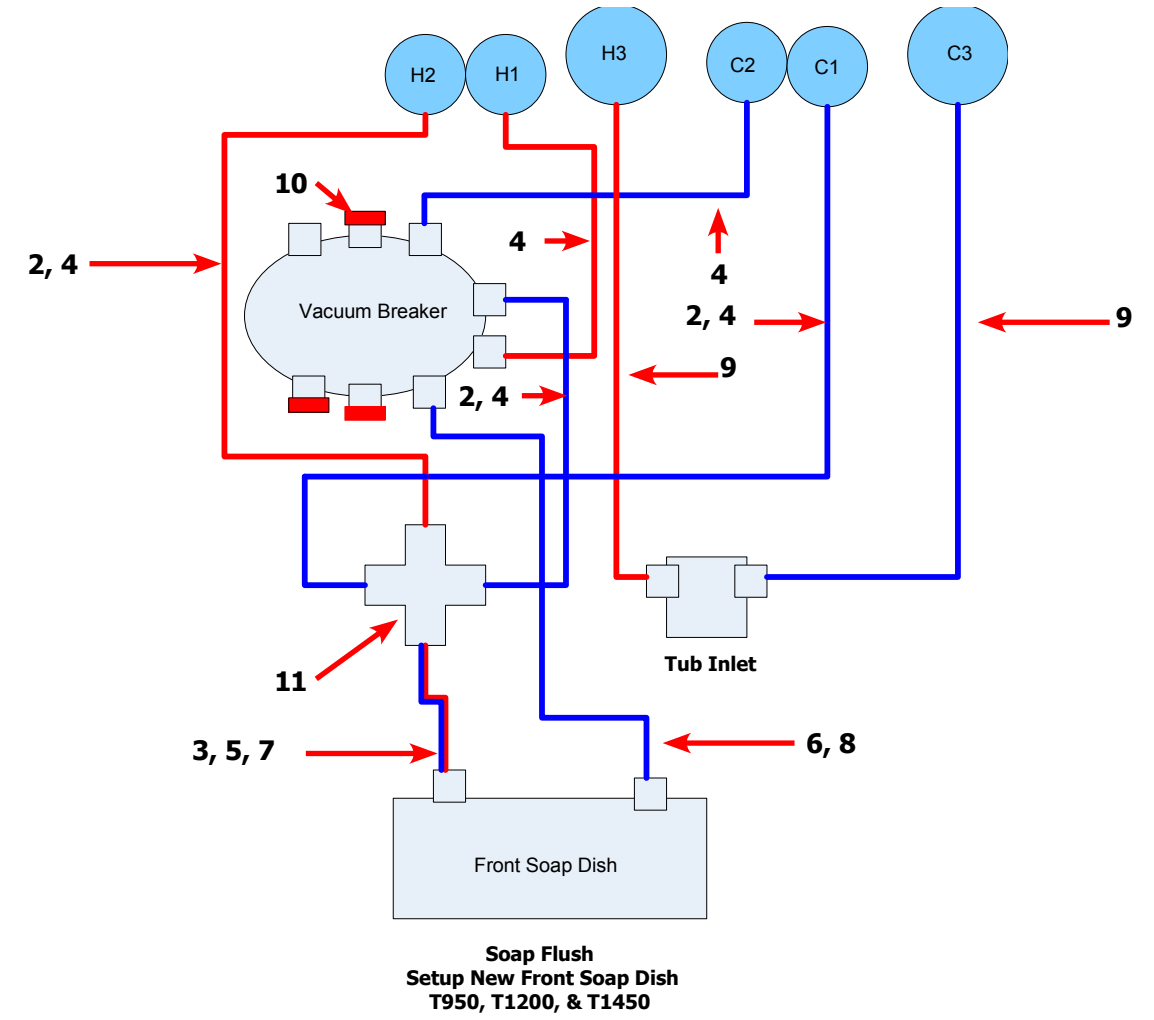
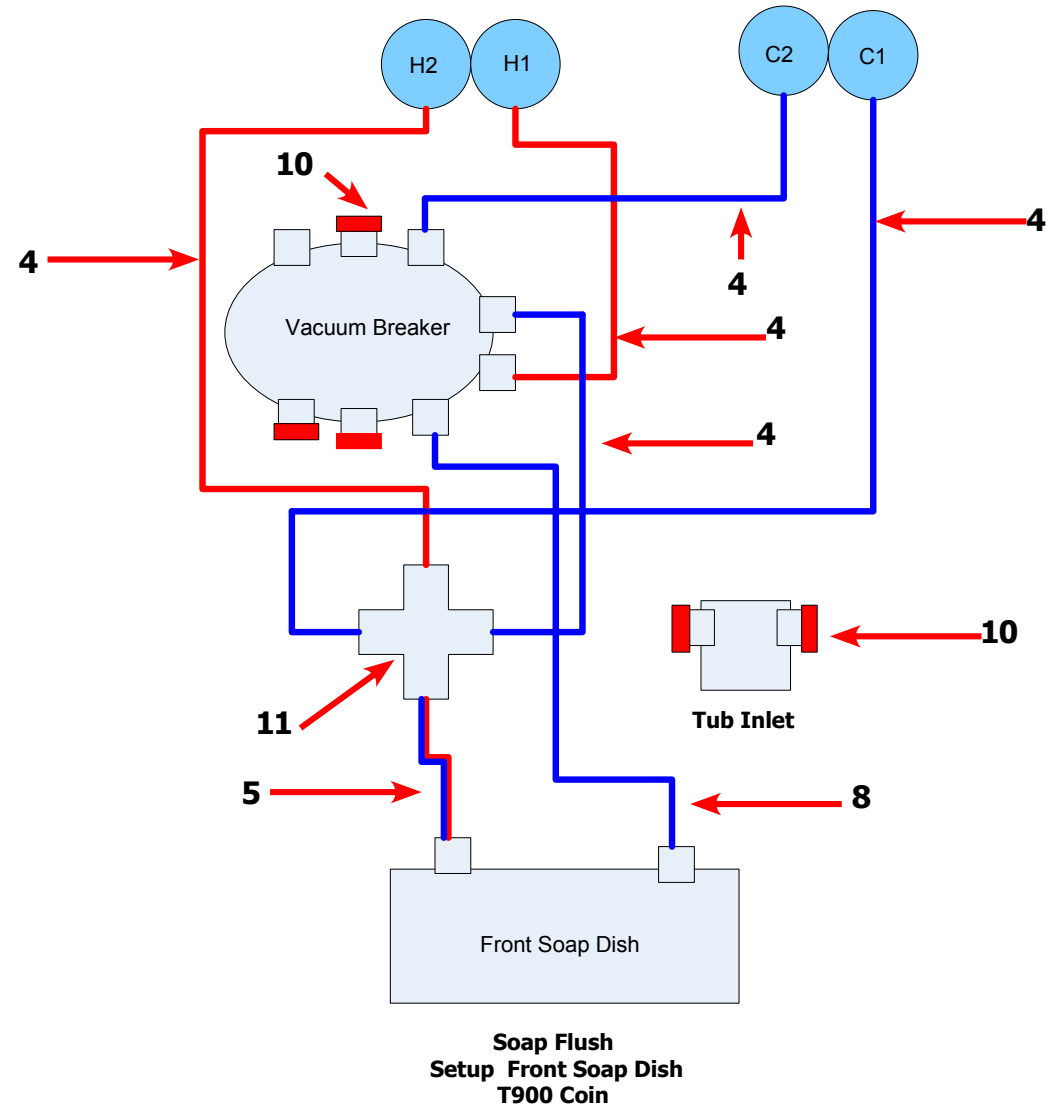

Key	Description	T-1800
2	9242-453-009 Hose-water,23" 1/2 I.D	3
4	9242-453-020 Hose-water,18" 1/2 I.D	2
5	9242-453-024 Hose-water,37" 1/2 I.D	1
6	9242-453-022 Hose-water,43" 1/2 I.D	1
9	9242-466-003 Hose-water,25" 7/8 I.D	2
10	0935-135-002 Fill Cap, (Red)	3
11	8615-118-001 Fitting-Cross, 1/2"	1
*	8654-117-015 Clamp 1" SS	14
*	8654-117-017 Clamp 1 1/4" SS	4

Water Inlet Valve Breakdown Part # by Model

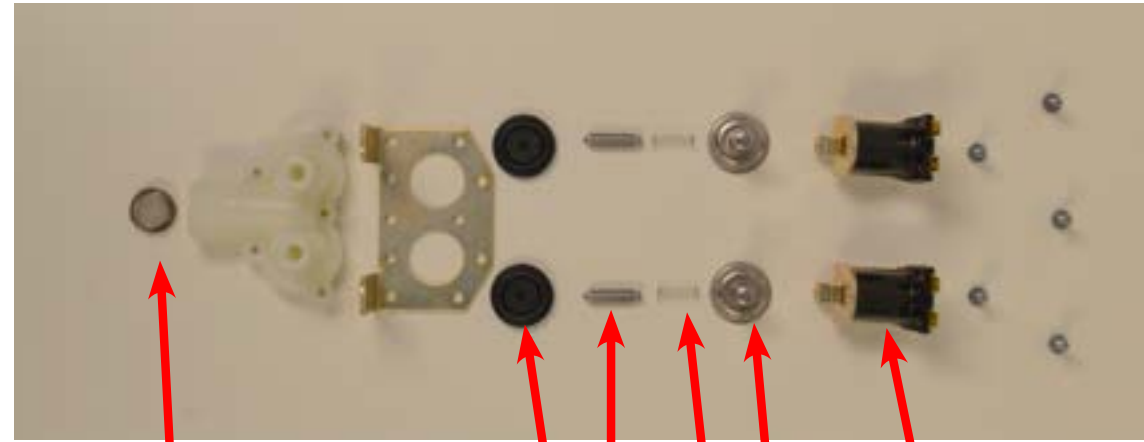

Key	Description	T-1800	QTY
*	Valve, Water Inlet (includes 1 thru 6) - Invensys	9379-183-012	2
1	Screen, Inlet end of valve	9555-056-001	2
2	Coil Assy., 120 V Invensys	9089-017-001	2
3	Diaphragm Invensys (EPDM)	9118-049-001	2
3	Diaphragm Invensys (Viton)	9118-049-002	2
3	Diaphragm Invensys (EPDM NSF)	9118-049-003	2
4	Guide, Solenoid Invensys	9211-021-002	2
5	Armature Invensys	9015-008-001	2
6	Spring, Armature Invensys	9534-298-001	2
*	Wiring Harness	9627-795-005	1

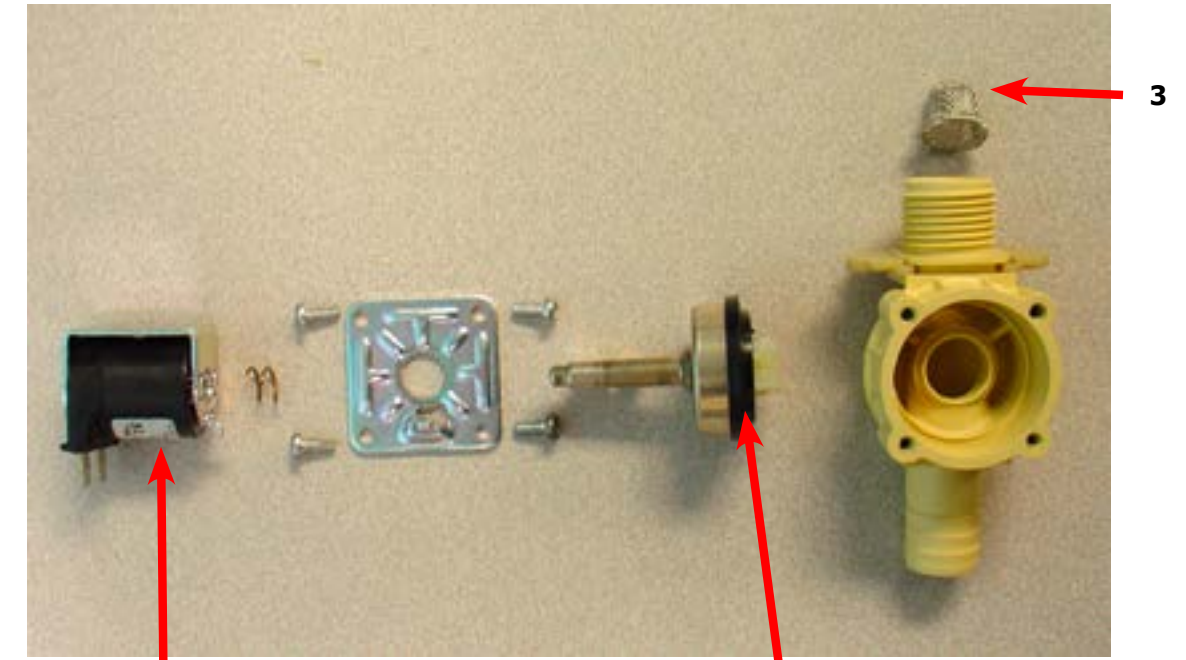

Key	Description	T-1800	QTY
*	Single Coil Water Valve Mueller	9379-194-001	1
1	Valve Water Body Complete (no coil)	9379-194-002	1
2	Diaphragm Mueller	9118-055-001	1
3	Filter Mueller	9183-046-001	1
4	Coil Mueller	9089-051-001	1

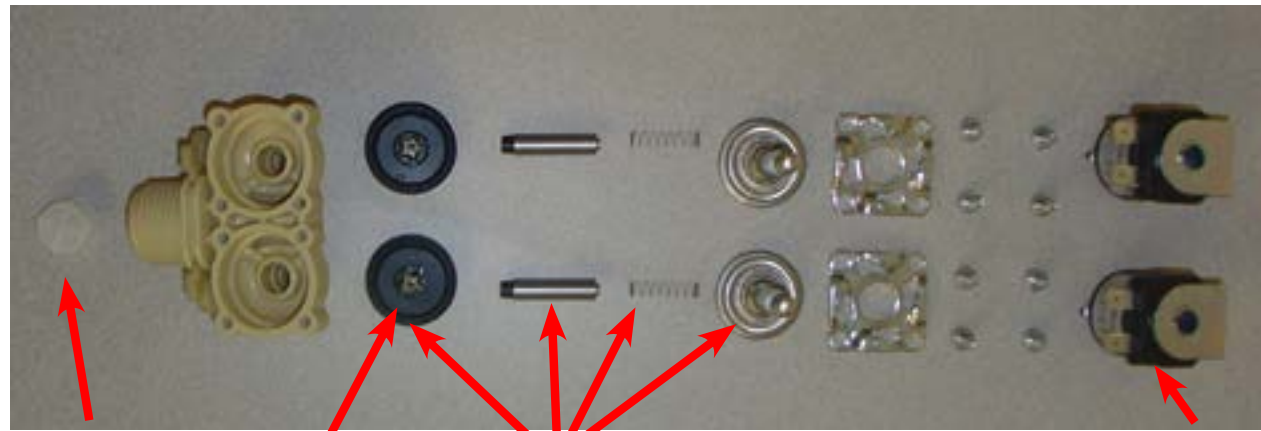

Optional Water Valve

Key	Description	T-1800	QTY
*	Dual Coil Water Valve Mueller	9379-192-001	1
7	Valve Water Body Complete(no coil)	9379-192-002	1
8	Diaphragm Mueller	9118-054-001	2
9	Filter Mueller	9183-046-001	2
10	Coil Mueller	9089-051-001	2
11	Diaphragm Assembly Mueller Includes	9785-001-001	2

Chassis and Drain Part # by Model

Key	Description	T-1800	QTY
1	Base Assy,Frame	9945-158-002	1
2	Outer Tub Assy	9930-187-001	1
*	Tub & Cylinder Assy	9869-046-001	1
3	Tub Front	9974-012-001	1
*	Gasket, Tub Front	9206-421-003	1
4	Ring Assy, Tub Mtg-Front Clamp	9950-061-001	1
5	Bolt, Top Front Ring 3/8"-16 x 3"	9545-029-009	1
6	Nut C Series 3/8"-16	8640-415-001	1
7	Bolt, 1/2" -13 x 2" (Tub Mounting to Frame)	9545-017-013	2
8	Nut, Wizloc 1/2" x 13	8640-417-005	2
9	Washer, Flat 1/2"	8641-581-026	2
10	Hose, Tub to Drain Valve	9242-456-001	1
11	Clamp, Hose (Tub to Drain Valve)	8654-117-014	2
12	Valve, Drain	9379-202-001	1
*	Screw, Valve to Base 1/4ABx3/4	9545-030-002	2
*	Washer, Flat 1/4	8641-581-018	4
13	Hose, Drain Valve to Tube	9242-457-002	1
*	Clamp, Hose (Drain Valve to Tube)	8654-117-014	2
14	Tube Assy, Drain	9915-129-002	1
15	Clamp, Hose (Tube to Frame Bracket)	8654-117-014	1
*	Bracket, Drain Tube	9029-067-004	1
*	Screw Tube (Bracket to Base 1/4Bx3/4)	9545-030-002	4
16	Hose, Overflow Tub To Drain Tube	9942-449-005	1
*	Clamp, Hose	8654-117-018	1
*	Tube, Suds overflow	9242-463-006	1
*	Clamp, Hose	8654-117-008	2
17	Hose, Pressure switch	9242-175-003	1
	Clamp, Overflow Hose	8654-117-015	1

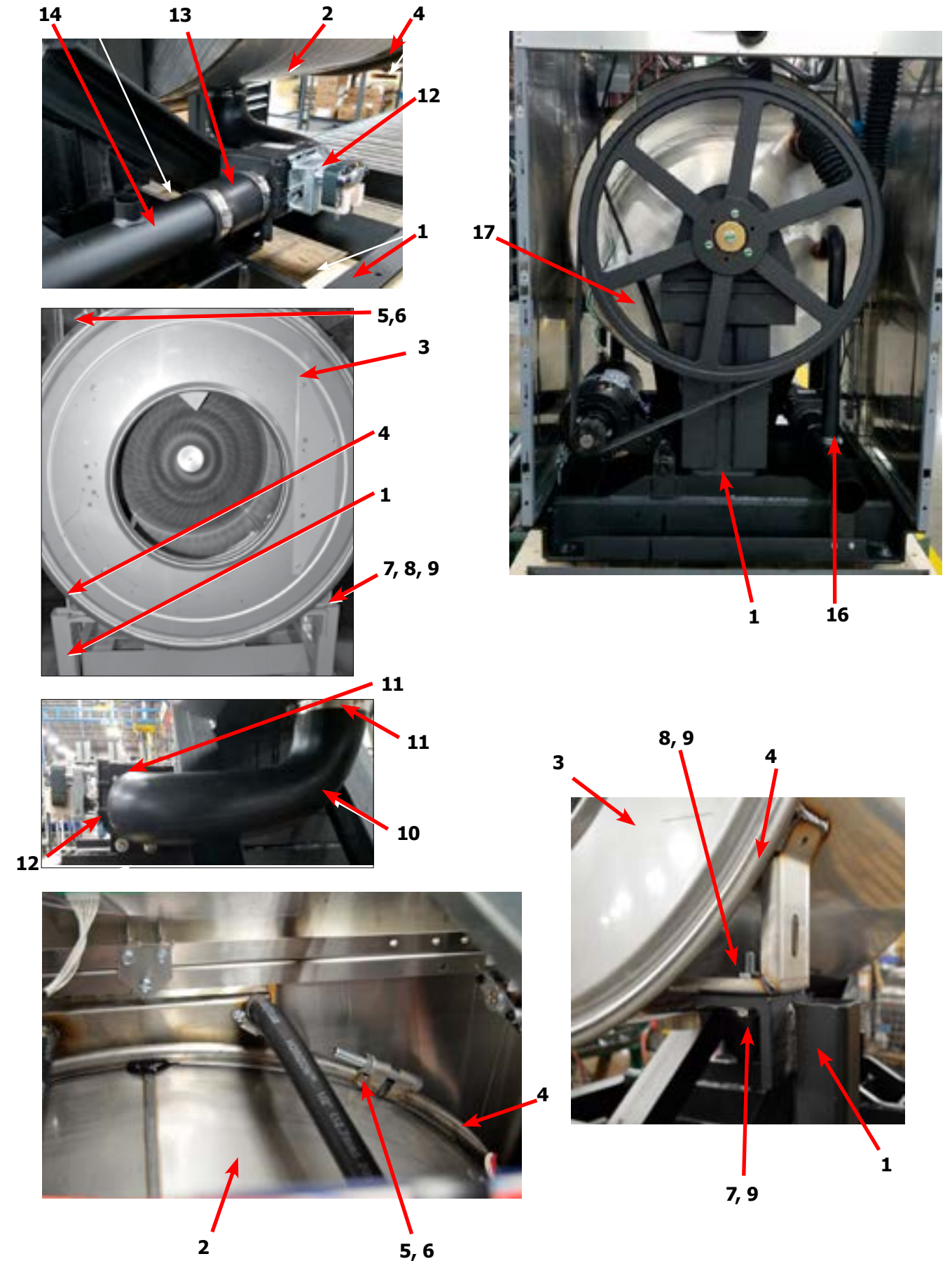

Key	Description	T-1800	QTY
1	Trough Assy,Controls 208-240 volt (all parts below #2-#43 & trough)	9857-272-001	1
*	Trough only	9839-017-001	1
*	Screw, Trough Sides	9545-008-026	4
*	Lockwasher #10	8641-582-006	4
2	Spreader-Chanel, Trough	9081-136-001	
*	Screw, Mtg #10Bx1/2"	9545-008-026	4
3	Transformer, Control (Secondary Voltage to 115 volts)	8711-004-001	1
*	Screw, Mtg #10Bx1/2"	9545-008-026	4
*	Lockwasher #10	8641-582-006	4
4	Screw GRN. #10-32x 1/2"	9545-008-027	1
5	Lockwasher #10	8641-582-006	1
6	Lug, Grounding	8652-130-037	1
7	PCB assembly Relay Main	9473-006-001	1
*	Support, Edge Holding	9548-285-001	6
*	Harness, P17 Drain/Therm/Sol	9627-796-002	1
*	Harness P19/Water Valve	9627-795-005	1
*	Harness P8/P16	9627-794-001	1
*	Harness P20/P21	9627-793-001	1
*	Bushing , Wire 7/8	9053-067-002	2
*	Standoff Twistlock	9527-002-002	3
8	Terminal Block Assy, POWER	9897-026-004	1
*	Screw, Mtg 8ABx1/2"	9545-045-012	2
*	Kit-Pressure Sensor, Electronic	9732-314-001	1
9	Kit-Repaacement, Pressure Sensor (only)	9732-315-001	1
*	Support-PCB, 3/8", Edge Holding	9548-285-001	4
*	Screw, Mtg #8Bx1/4"	9545-045-001	2
*	Harness P5/Pressure	9627-908-013	1
10	Transformer, (Step Down) 120/24VAC 50/60hz	8711-009-006	1
*	Screw, Transformer Mtg #8Bx1/4"	9545-045-001	4
*	Lockwasher #6 exttooth	8641-582-005	4
11	Fuseholder	9200-001-002	1
*	Fuse 2.5 amp	8636-018-004	1
12	Label Fuse 2.5 amp Rear	8502-716-002	1
13	Angle Support Trough	9029-318-001	1
*	Screw, Trough Bracket	9545-008-026	4
14	Chanel-Support, Trough	9081-173-001	1
*	Screw, Mtg #10Bx1/2"	9545-008-026	4
15	Chanel	9081-108-002	1
*	Screw, Mtg #10Bx1/2"	9545-008-026	2
*	Wire Assy BLK/BLU	8220-001-231	1
*	Wire Assy RED/BLU	8220-001-230	1

Electrical Components - Top Compartment

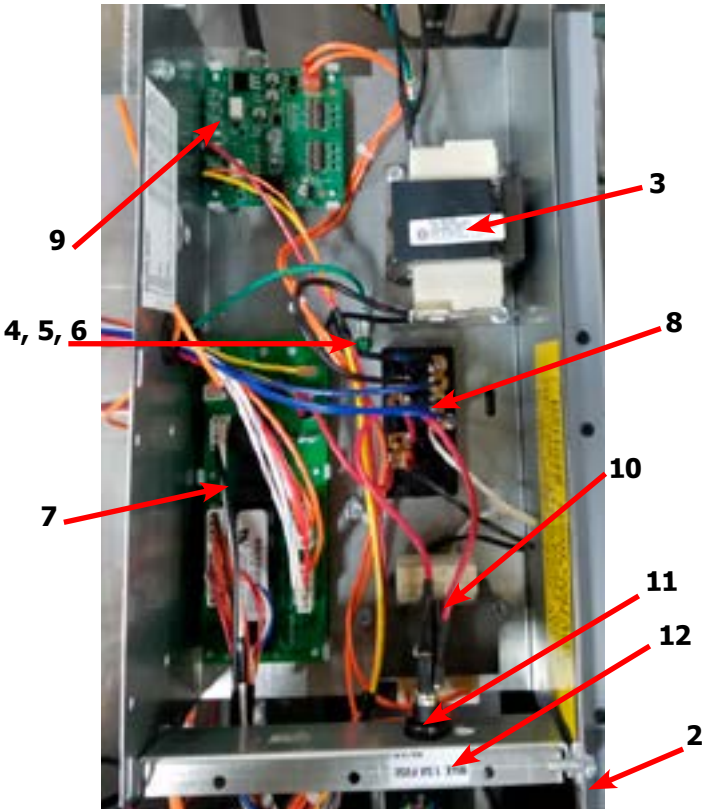
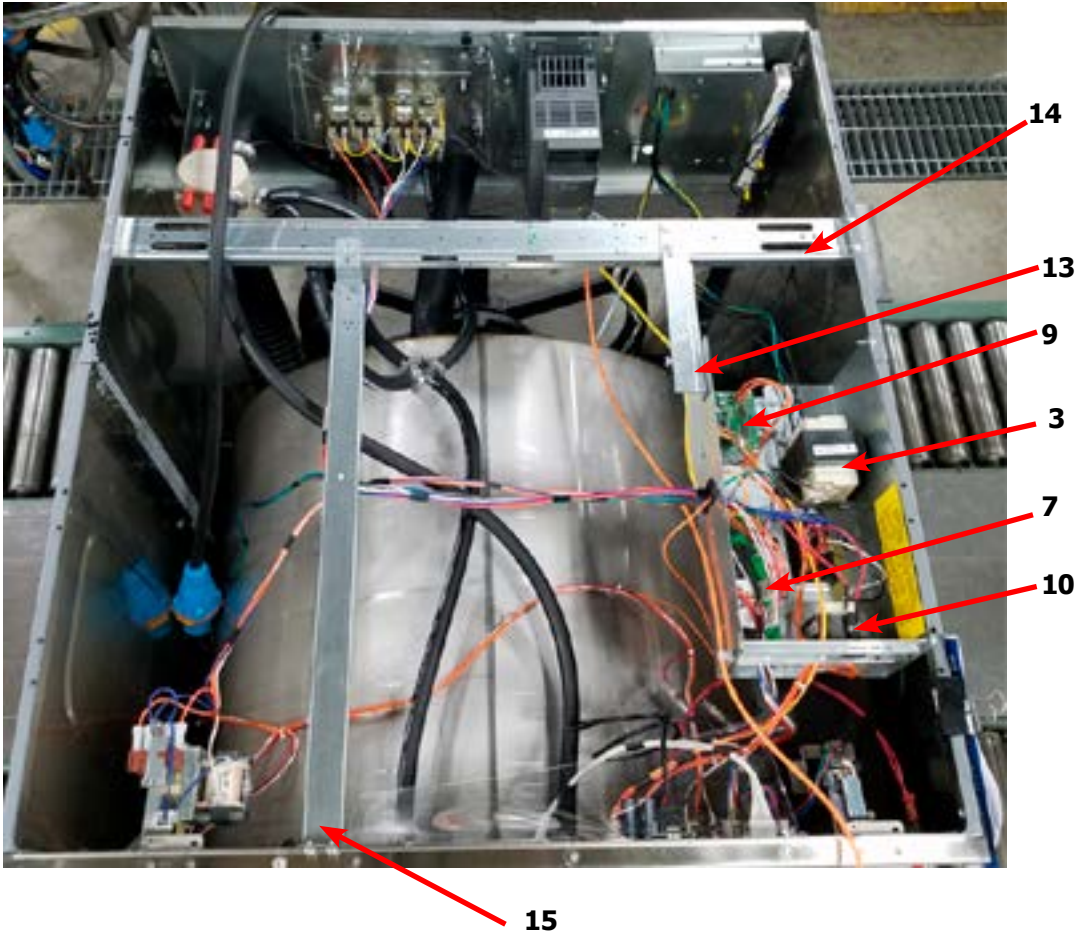

Control Panel Part # by Model

Key	Description	T-1800	QTY
1	Panel Control Assembly(panel only)	9989-561-001	1
*	Screw, to Side Panels 5/16, Hxwshrdndct #10Bx 1/2"	9545-008-026	4
2	Plate-Latch, Top	9452-625-001	2
3	Nut, #8-32	8640-412-005	4
4	Locator Panel	9355-001-001	1
5	Screw FillHDCR 10Bx1/2" Guide	9545-008-023	1
6	Spacer Pushbutton (Micro)	9538-192-001	1
7	Pushbutton Control (coin)[Blue]	9035-062-001	1
7	Pushbutton Control (coin)[Black]	9035-062-002	1
8	Retainer Pushbutton (Micro)	9486-160-001	1
9	Nut Hexelasticstop #4-40	8640-424-002	2
10	Spacer Plastic #6x9/16	9538-157-018	5
11	PCB assembly Control /Display STOP	9473-010-001	1
12	Nut Elasticstop #6-32	8640-411-002	4
13	Nut-Hexkeps, #6-32	8640-411-003	1
14	Harness LEDPCB	9627-797-001	1
*	Harness Doorlock, Switches	9627-791-005	1
15	Spacer Plastic #6x9/16	9538-157-018	2
16	PCB assembly Mode lights	9473-005-001	1
17	Nut Hexkeps #6-32	8640-411-003	2
18	Acceptor-Coin, Optical	9021-092-002	1
19	Retainer, Coin Acceptor	9486-149-001	2
20	Screws, Torx, T-10, 4Bx3/8ss	9545-053-002	4
21	Switch Assembly Emergency Stop (includes wire harness)	9732-223-001	1
22	Spacer Plastic #8x5/16 E-Stop	9538-157-020	2
23	Plate to mount e-stop button	9452-725-001	1
24	Nuts-Hexkeps, #8-32	8640-412-005	3
25	Plastic Shield over main PCB	9550-184-001	1
26	Nuts-Hexkeps, #8-32	8640-412-005	3
27	Nameplate,Control Panel (Blue)	9412-216-002	1
27	Nameplate,Control Panel (Black)	9412-216-001	1
28	Motor Ass'y, Door Locking (see Door Lock Group for parts breakdown)	9892-015-001	1
29	Nuts-Hexkeps, #8-32	8640-412-005	4
*	Battery	8612-001-001	1
30	Cable, USB	9806-022-001	1
*	USB Retainer	9486-159-001	*
31	Screw-Torx T10, #4-40x3/8ss	9545-053-002	2
32	Nut, Spring	8640-442-001	2

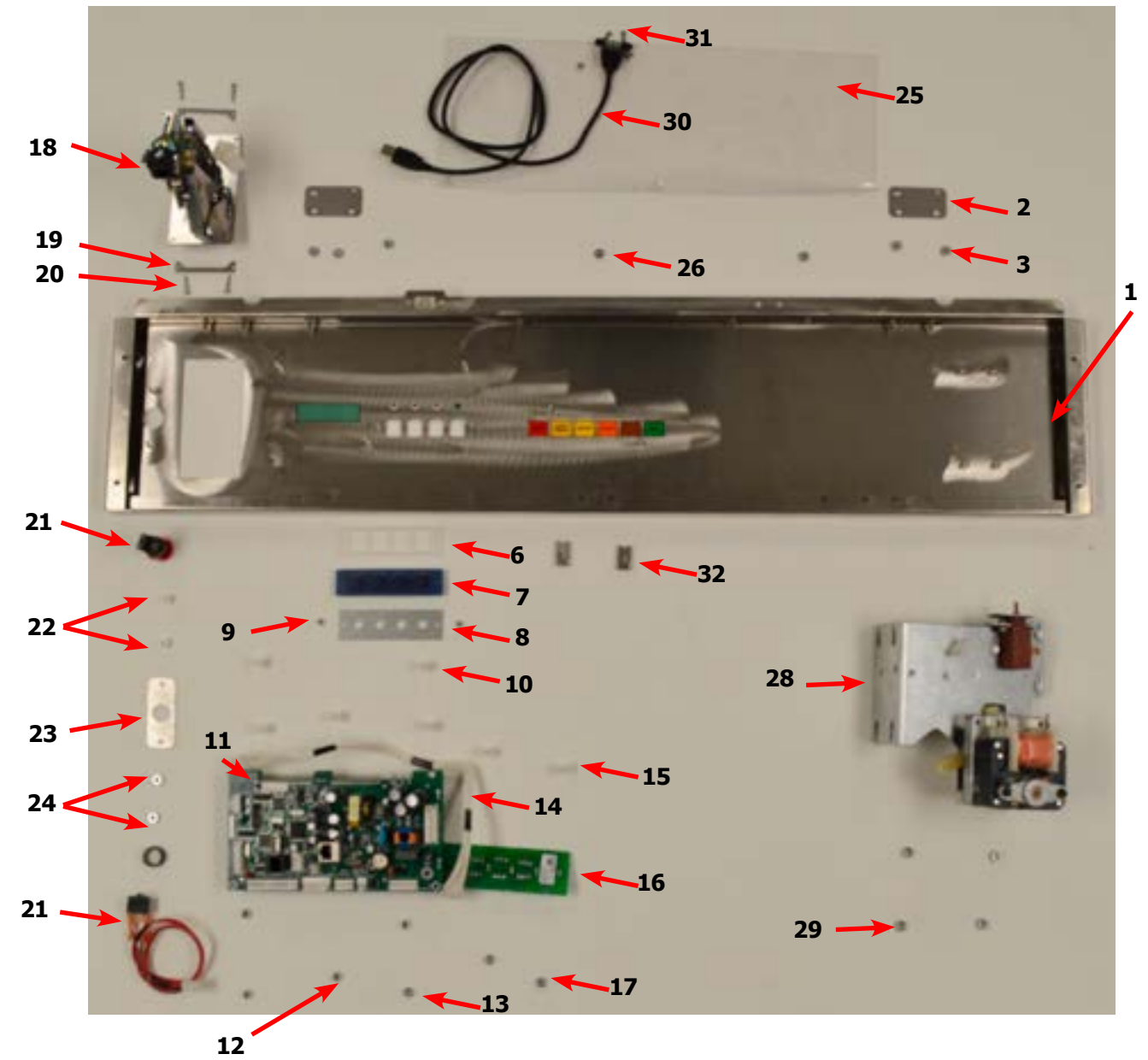

Labels and Diagrams

Key	Description	T-1800	QTY
*	Wiring Diagram and Schematic, Coin	9506-871-001	1
*	Transient Voltage Surge Suppressor Infomational	8507-330-001	1
*	Label High Voltage Warning	8502-614-004	1
*	Label Fusing & Installation	8502-619-003	1
*	Label Quality	8511-001-002	1
1	Label Warning Door Opening (Blue)	8502-757-002	1
1	Label Warning Door Opening (Black)	8502-757-001	1
2	Label Warning Risk of Injury (Blue)	8502-759-002	1
2	Label Warning Risk of Injury (Black)	8502-759-001	1
3	Label Dispenser (Blue)	8502-756-002	1
3	Label Dispenser (Black)	8502-756-001	1
*	Booklet Owners	8514-296-001	1



Section 9:

Coin Handling
Parts:
Wiring Diagrams
& Schematics &
maintenance Procedures

Optical Coin Acceptor

Key	Description	T-1800	QTY
1	Optical Coin Acceptor	9021-092-002	1
2	Replacement Optical Sensor	9801-099-001	1
*	Screw, Highth Bar, 3mm	9545-039-002	2

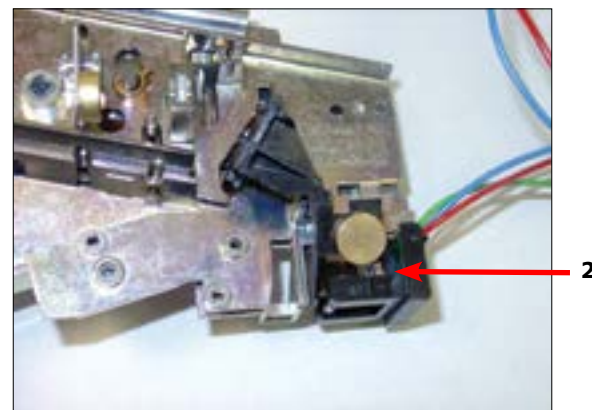
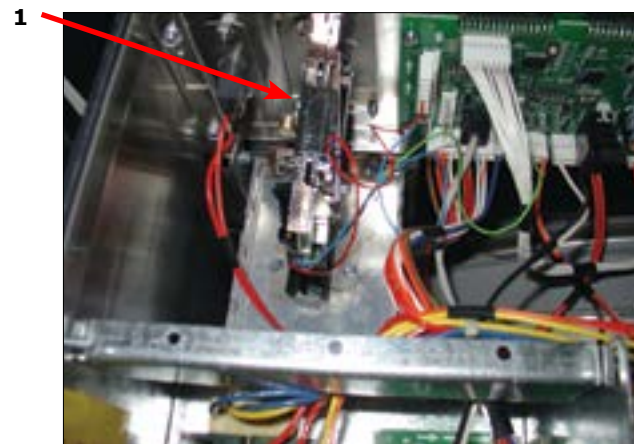
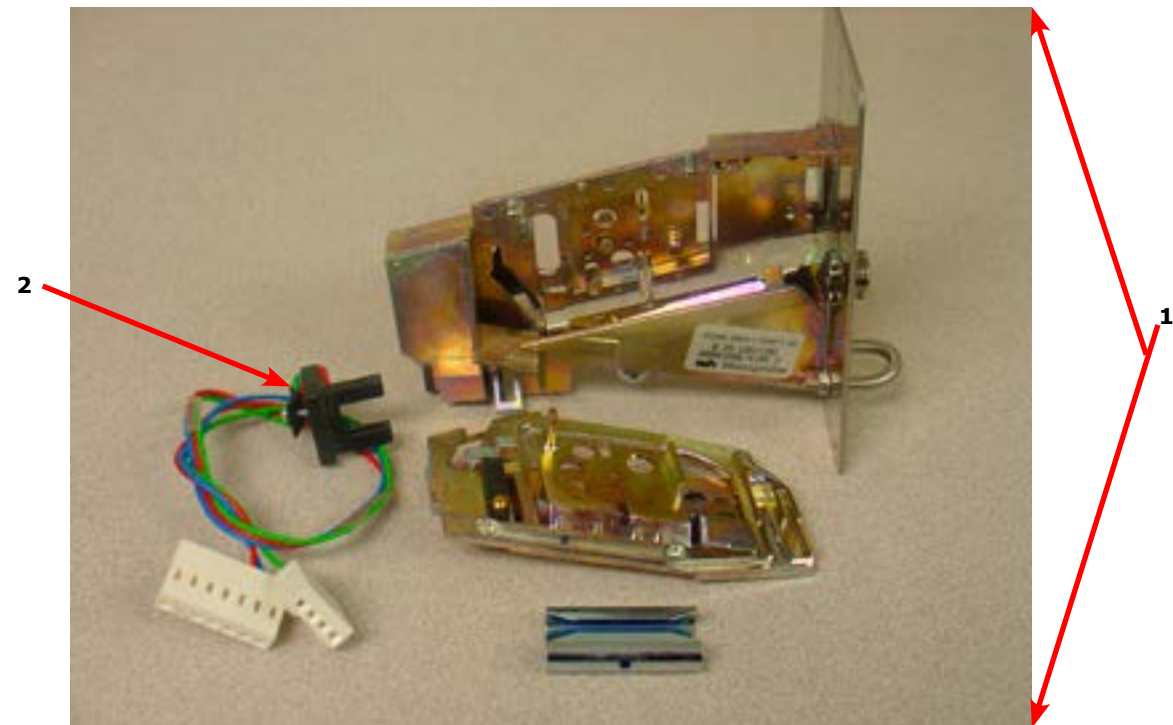

Kit - Electronic Acceptor Conversion for C-Series (USA and Canada)

Key	Description	T-1800	QTY
	KIT - Electronic Acceptor Conversion for C Series (USA and Canada) Contact the Dexter Factory for Other Countries	9732-301-004	1
1	Electronic Coin Acceptor (USA and Canada)	9021-077-001	1
2	Harness for Electronic Coin Acceptor	9627-909-001	1
3	Transformer 120/18VAC	8711-015-001	1
*	Wire Assembly - Blue	8220-001-338	1
*	Wire Assembly - Orange/White	8220-001-235	1
4	Coin Chute for Electronic Drop	9119-028-001	1
*	Nut - Hex Elastic Stop	8640-424-002	1
*	Screw, Torx	9545-020-004	4
*	Screw, Hex	9545-045-001	4
*	Label, Informative	6102-017-001	2
*	Label, Warning	8502-730-001	1
*	Instructions, Installation	8507-456-004	1
5	Coin Chute for Electronic Drop	9119-030-001	1

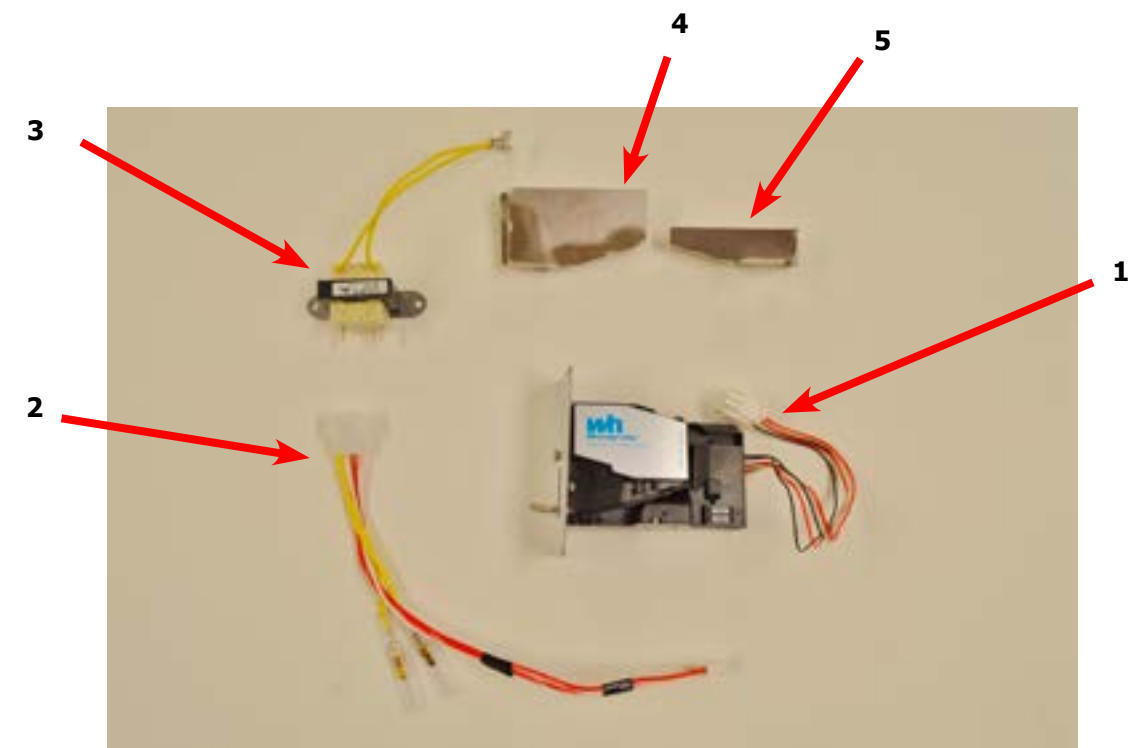

Electronic Acceptor Coin Drop

Setting the electronic coin acceptor switches

Some washer models come equipped with an electronic acceptor. Follow the instructions below for setting the switches for the desired country and currencies.

1. The electronic coin acceptor has switch settings depending on the coins and country. See the table below for available values of the left and right coin inputs for the available countries.

WARNING: turn power off before and leave power off when changing the switches of the electronic coin acceptor.

2. Turn power back on and test coins to ensure proper operation.



Dip Switches

Coin Acceptor Switch Settings

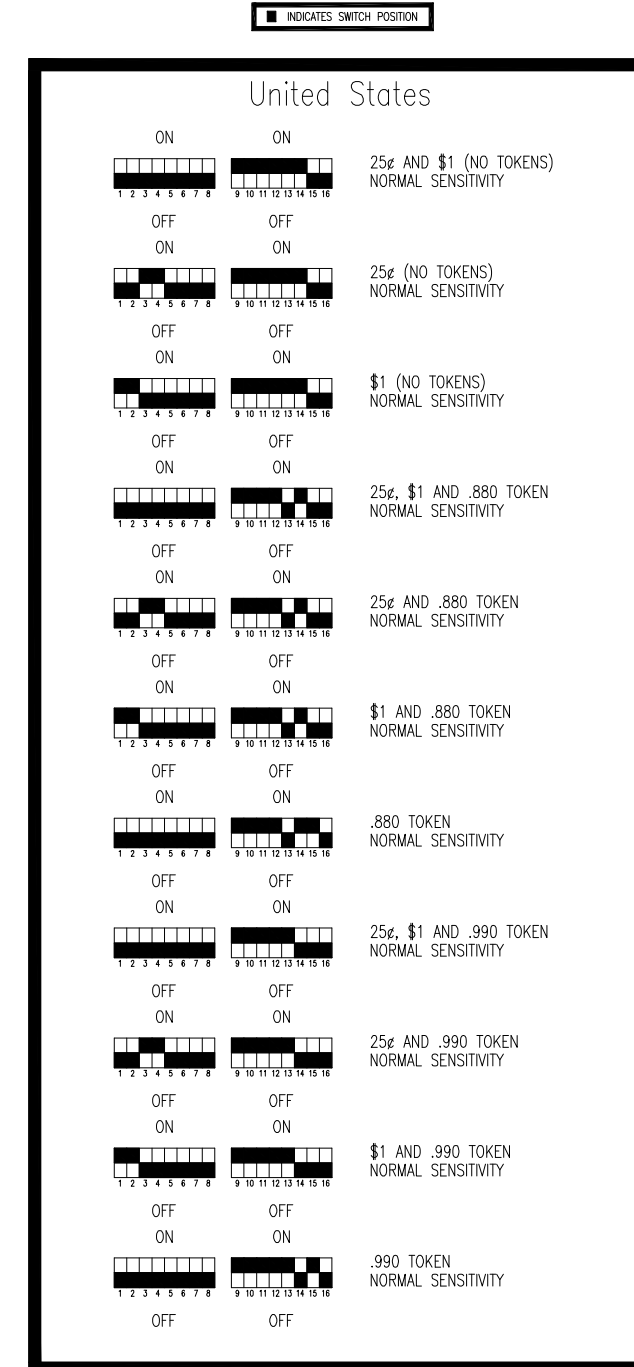

25¢ – one pulse on left washer/dryer input
 \$1 – one pulse on right washer/dryer input
 .880 TOKEN – one pulse on left washer/dryer input
 .990 TOKEN – one pulse on right washer/dryer input

Coin Acceptor Switch Settings

■ INDICATES SWITCH POSITION

Canada

ON ON
25¢, \$1(OLD & NEW), \$2(OLD & NEW)
(NO TOKENS) NORMAL SENSITIVITY

OFF OFF
ON ON
\$1(OLD & NEW) AND \$2(OLD & NEW)
(NO TOKENS) NORMAL SENSITIVITY

OFF OFF
ON ON
25¢ AND \$2(OLD & NEW)
(NO TOKENS) NORMAL SENSITIVITY

OFF OFF
ON ON
25¢ AND \$1(OLD & NEW)
(NO TOKENS) NORMAL SENSITIVITY

OFF OFF
ON ON
25¢ (NO TOKENS)
NORMAL SENSITIVITY

ON ON
\$2(OLD & NEW)
(NO TOKENS) NORMAL SENSITIVITY

OFF OFF
ON ON
\$1(OLD & NEW)
(NO TOKENS) NORMAL SENSITIVITY

OFF OFF
ON ON
25¢, \$1(NEW ONLY), \$2(NEW ONLY)
(NO TOKENS) NORMAL SENSITIVITY

OFF OFF
ON ON
\$1(NEW ONLY) AND \$2(NEW ONLY)
(NO TOKENS) NORMAL SENSITIVITY

OFF OFF
ON ON
25¢ AND \$2(NEW ONLY)
(NO TOKENS) NORMAL SENSITIVITY

OFF OFF
ON ON
25¢ AND \$1(NEW ONLY)
(NO TOKENS) NORMAL SENSITIVITY

OFF OFF
ON ON
\$2(NEW ONLY)
(NO TOKENS) NORMAL SENSITIVITY

OFF OFF
ON ON
\$1(NEW ONLY)
(NO TOKENS) NORMAL SENSITIVITY

Canada

ON ON
25¢, \$1(OLD & NEW), \$2(OLD & NEW)
AND .880 TOKEN NORMAL SENSITIVITY

OFF OFF
ON ON
\$1(OLD & NEW), \$2(OLD & NEW)
AND .880 TOKEN NORMAL SENSITIVITY

OFF OFF
ON ON
25¢, \$2(OLD & NEW) AND
.880 TOKEN NORMAL SENSITIVITY

OFF OFF
ON ON
25¢, \$1(OLD & NEW) AND
.880 TOKEN NORMAL SENSITIVITY

OFF OFF
ON ON
25¢ AND .880 TOKEN
NORMAL SENSITIVITY

OFF OFF
ON ON
\$2(OLD & NEW) AND
.880 TOKEN NORMAL SENSITIVITY

OFF OFF
ON ON
\$1(OLD & NEW) AND
.880 TOKEN NORMAL SENSITIVITY

OFF OFF
ON ON
25¢, \$1(NEW ONLY), \$2(NEW ONLY)
AND .880 TOKEN NORMAL SENSITIVITY

OFF OFF
ON ON
\$1(NEW ONLY), \$2(NEW ONLY) AND
.880 TOKEN NORMAL SENSITIVITY

OFF OFF
ON ON
25¢, \$2(NEW ONLY) AND
.880 TOKEN NORMAL SENSITIVITY

OFF OFF
ON ON
25¢, \$1(NEW ONLY) AND
.880 TOKEN NORMAL SENSITIVITY

OFF OFF
ON ON
\$2(NEW ONLY) AND
.880 TOKEN NORMAL SENSITIVITY

OFF OFF
ON ON
\$1(NEW ONLY) AND
.880 TOKEN NORMAL SENSITIVITY

25¢ – one pulse on left washer/dryer input
 \$1 – one pulse on right washer/dryer input
 \$2 – two pulses on right washer/dryer input
 .880 TOKEN – one pulse on right washer/dryer input
 .990 TOKEN – one pulse on right washer/dryer input

Coin Acceptor Switch Settings

■ INDICATES SWITCH POSITION

Canada

ON ON
25¢, \$1(OLD & NEW), \$2(OLD & NEW)
AND .990 TOKEN NORMAL SENSITIVITY

OFF OFF
ON ON
\$1(OLD & NEW), \$2(OLD & NEW)
AND .990 TOKEN NORMAL SENSITIVITY

OFF OFF
ON ON
25¢, \$2(OLD & NEW) AND
.990 TOKEN NORMAL SENSITIVITY

OFF OFF
ON ON
25¢, \$1(OLD & NEW) AND
.990 TOKEN NORMAL SENSITIVITY

OFF OFF
ON ON
25¢ AND .990 TOKEN
NORMAL SENSITIVITY

OFF OFF
ON ON
\$2(OLD & NEW) AND
.990 TOKEN NORMAL SENSITIVITY

OFF OFF
ON ON
\$1(OLD & NEW) AND
.990 TOKEN NORMAL SENSITIVITY

OFF OFF
ON ON
25¢, \$1(NEW ONLY), \$2(NEW ONLY)
AND .990 TOKEN NORMAL SENSITIVITY

OFF OFF
ON ON
\$1(NEW ONLY), \$2(NEW ONLY) AND
.990 TOKEN NORMAL SENSITIVITY

OFF OFF
ON ON
25¢, \$2(NEW ONLY) AND
.990 TOKEN NORMAL SENSITIVITY

OFF OFF
ON ON
25¢, \$1(NEW ONLY) AND
.990 TOKEN NORMAL SENSITIVITY

OFF OFF
ON ON
\$2(NEW ONLY) AND
.990 TOKEN NORMAL SENSITIVITY

OFF OFF
ON ON
\$1(NEW ONLY) AND
.990 TOKEN NORMAL SENSITIVITY

Canada

ON ON
25¢, \$1(OLD & NEW), \$2(OLD & NEW),
.880 AND .990 TOKEN NORMAL
SENSITIVITY

OFF OFF
ON ON
\$1(OLD & NEW), \$2(OLD & NEW),
.880 AND .990 TOKEN NORMAL
SENSITIVITY

OFF OFF
ON ON
25¢, \$2(OLD & NEW), .880 AND
.990 TOKEN NORMAL SENSITIVITY

OFF OFF
ON ON
25¢, \$1(OLD & NEW), .880 AND
.990 TOKEN NORMAL SENSITIVITY

OFF OFF
ON ON
25¢, .880 AND .990 TOKEN
NORMAL SENSITIVITY

OFF OFF
ON ON
\$2(OLD & NEW), .880 AND
.990 TOKEN NORMAL SENSITIVITY

OFF OFF
ON ON
\$1(OLD & NEW), .880 AND
.990 TOKEN NORMAL SENSITIVITY

OFF OFF
ON ON
25¢, \$1(NEW ONLY), \$2(NEW ONLY),
.880 AND .990 TOKEN NORMAL
SENSITIVITY

OFF OFF
ON ON
\$1(NEW ONLY), \$2(NEW ONLY), .880
AND .990 TOKEN NORMAL
SENSITIVITY

OFF OFF
ON ON
25¢, \$2(NEW ONLY), .880 AND
.990 TOKEN NORMAL SENSITIVITY

OFF OFF
ON ON
25¢, \$1(NEW ONLY), .880 AND
.990 TOKEN NORMAL SENSITIVITY

OFF OFF
ON ON
\$2(NEW ONLY), .880 AND
.990 TOKEN NORMAL SENSITIVITY

OFF OFF
ON ON
\$1(NEW ONLY), .880 AND
.990 TOKEN NORMAL SENSITIVITY

25¢ – one pulse on left washer/dryer input
 \$1 – one pulse on right washer/dryer input
 \$2 – two pulses on right washer/dryer input
 .880 TOKEN – one pulse on right washer/dryer input
 .990 TOKEN – one pulse on right washer/dryer input

Notes

Lined area for notes, consisting of approximately 35 horizontal lines.