



# **AD-4545**

# **Parts Manual**

## **Phase 7**

---

**American Dryer Corporation**  
88 Currant Road  
Fall River, MA 02720-4781  
Telephone: (508) 678-9000 / Fax: (508) 678-9447  
E-mail: [techsupport@amdry.com](mailto:techsupport@amdry.com)

[www.amdry.com](http://www.amdry.com)

# Retain This Manual In A Safe Place For Future Reference

American Dryer Corporation products embody advanced concepts in engineering, design, and safety. If this product is properly maintained, it will provide many years of safe, efficient, and trouble free operation.

**ONLY qualified technicians should service this equipment.**

**OBSERVE ALL SAFETY PRECAUTIONS** displayed on the equipment or specified in the installation manual included with the dryer.

The following “**FOR YOUR SAFETY**” caution must be posted near the dryer in a prominent location.

## FOR YOUR SAFETY

Do not store or use gasoline or other flammable vapors and liquids in the vicinity of this or any other appliance.

## POUR VOTRE SÉCURITÉ

Ne pas entreposer ni utiliser d'essence ni d'autres vapeurs ou liquides inflammables à proximité de cet appareil ou de tout autre appareil.

We have tried to make this manual as complete as possible and hope you will find it useful. ADC reserves the right to make changes from time to time, without notice or obligation, in prices, specifications, colors, and material, and to change or discontinue models.

## Important

For your convenience, log the following information:

DATE OF PURCHASE \_\_\_\_\_ MODEL NO. **AD-4545**  
RESELLER'S NAME \_\_\_\_\_  
Serial Number(s) \_\_\_\_\_  
\_\_\_\_\_  
\_\_\_\_\_

Replacement parts can be obtained from your reseller or the ADC factory. When ordering replacement parts from the factory, you can FAX your order to ADC at (508) 678-9447 or telephone your order directly to the ADC Parts Department at (508) 678-9000. Please specify the dryer model number and serial number in addition to the description and part number, so that your order is processed accurately and promptly.

The illustrations on the following pages may not depict your particular dryer exactly. The illustrations are a composite of the various dryer models. Be sure to check the descriptions of the parts thoroughly before ordering.

### **“IMPORTANT NOTE TO PURCHASER”**

Information must be obtained from your local gas supplier on the instructions to be followed if the user smells gas. These instructions must be posted in a prominent location near the dryer.

# Table of Contents

Coin Microprocessor Control Panel Assembly .....	4
Top and Bottom Front Panels and Door Assembly .....	5
Coin Box Assembly, Vault and Coin Chute .....	6
Tumbler and Basket Support and Hi-Limit Assembly .....	7
Microprocessor Temperature Sensor Bracket Assembly .....	8
Locking Lint Drawer Assembly .....	9
Tumbler Bearing Support Assembly .....	10
Drive and Idler Belts / Pulleys .....	11
Totally Enclosed, Fan-Cooled Motor Mount Assembly .....	12
Sail Switch Assembly .....	13
Natural Gas Burner Assembly .....	14
Single-Phase (1Ø) Top Motor Electrical Relay Panel Assembly .....	15
Single-Phase (1Ø) Bottom Motor Electrical Relay Panel Assembly .....	16
3-Phase (3Ø) Top Motor, Electrical Relay Panel Assembly .....	17
3-Phase (3Ø) Bottom Motor, Electrical Relay Panel Assembly .....	18
Exhaust, Back Guard, and Burner Assembly .....	19

# Coin Microprocessor Control Panel Assembly

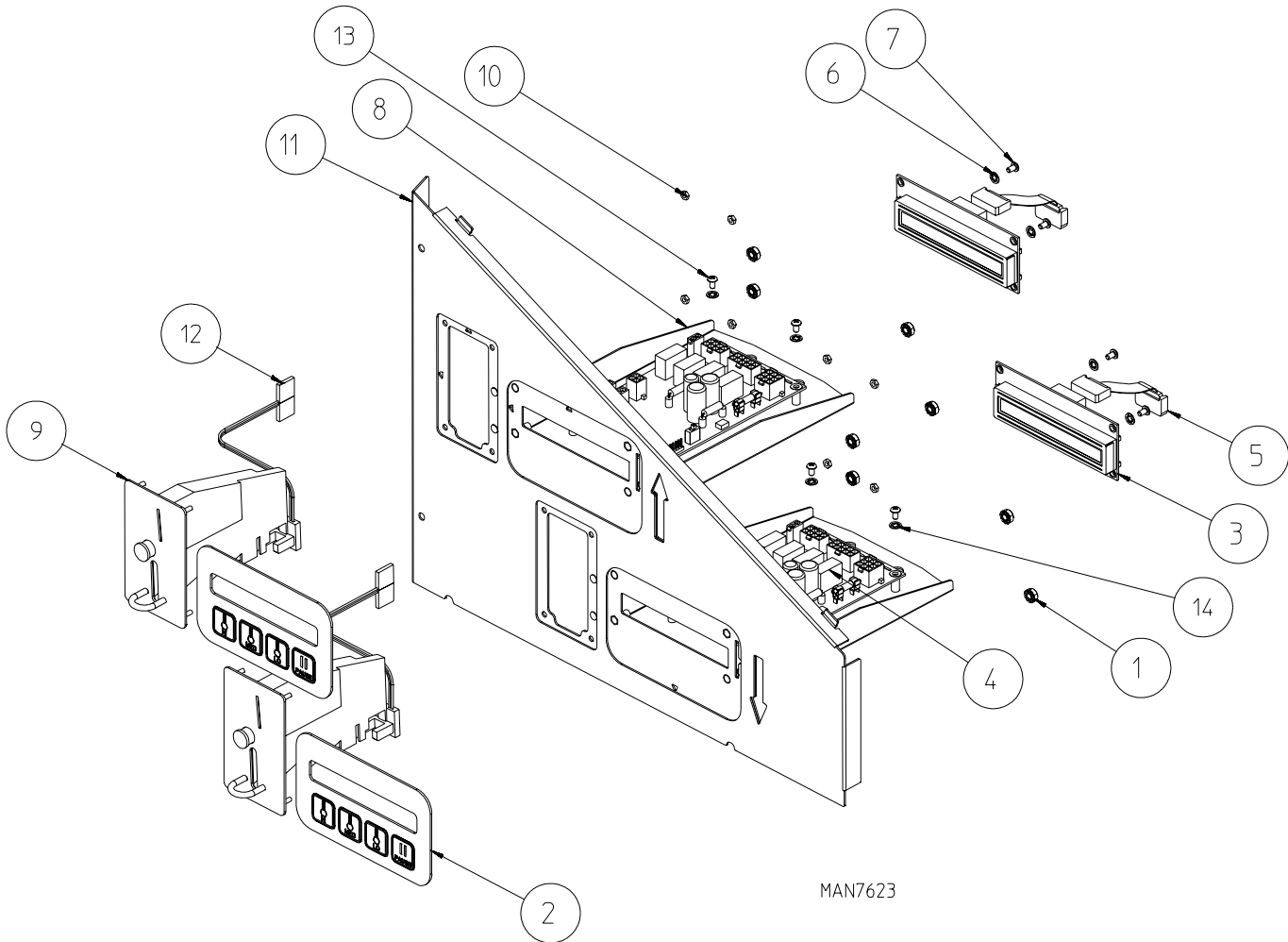

MAN7623

<u>Illus. No.</u>	<u>Part No.</u>	<u>Qty.</u>	<u>Description</u>
1	153073	8	#8-32 Keps Nut
2	112575	1	Phase 7.3 Coin Keypad
3	137270	1	Large Character Display
4	137253	1	Phase 7.3.2 Coin Board
5	137250	1	Phase 7 Coin Ribbon Cable
6	153010	8	#6 Internal Star Washer
7	150005	8	#6-32 x 1/4" Phillips Screw
8	845760	1	Computer Board Mount
9	852317	1	.25 US Hanke Coin Acceptor Assembly
10	152102	8	M3 Metric Nut
11	845762	1	Cold Rolled Steel Control Panel (white)
	845813	1	Stainless Steel Control Panel
12	883774	1	Hanke Phase 7 Optic Switch Assembly
13	150005	4	#6-32 x 1/4" Phillips Screw
14	153010	4	#6 Internal Star Washer

# Top and Bottom Front Panels and Door Assembly

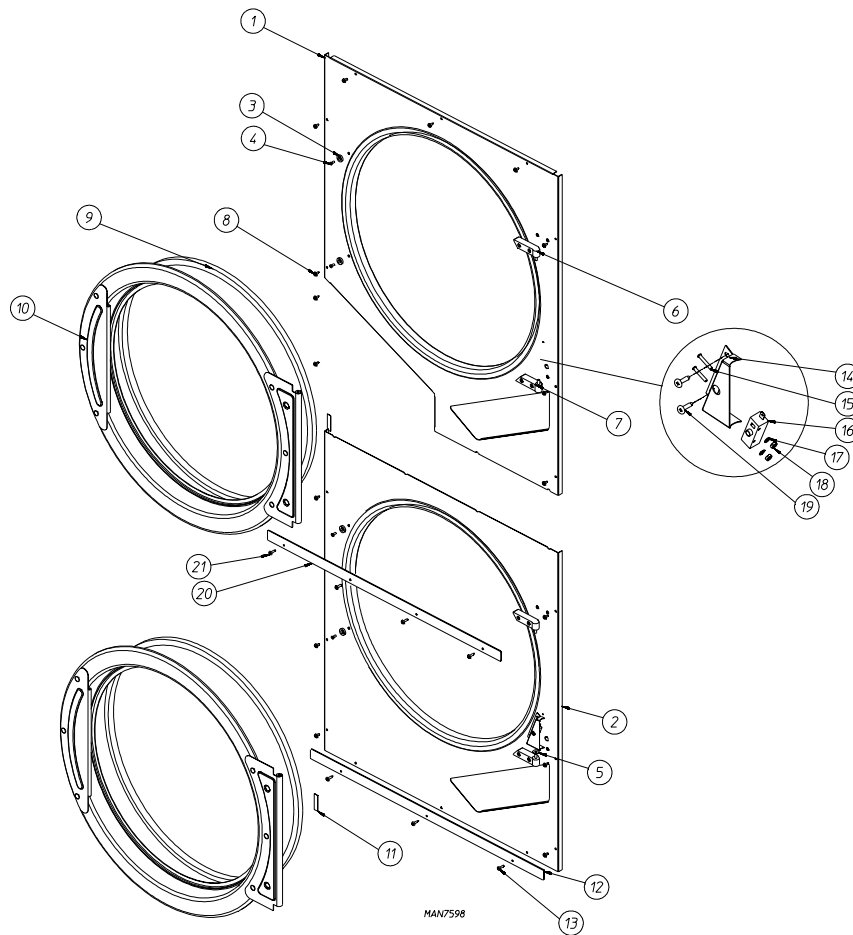

Illus. No.	Part No.	Qty.	Description
1	845797	1	Top Cold Rolled Steel Front Panel (white)
	845819	1	Stainless Steel Top Front Panel
2	845794	1	Bottom Cold Rolled Steel Coin Front Panel (white)
	845809	1	Bottom Cold Rolled Steel Non-Coin Front Panel (white)
	845816	1	Bottom Stainless Steel Coin Front Panel
	845841	1	Bottom Stainless Steel Non-Coin Front Panel
3	102004	2	Door Magnet
4	152223	2	#10-32 x 1/2" T-20 TORX® Machine Screw
5	153031	1	Nylon Washer
6	800293	1	Top Hinge Block Assembly (black)
7	800292	1	Bottom Hinge Block Assembly (black)
8	150313	16	#10-16 x 1/2" TORX PLUS®
9	185512	1	31-1/4" Main Door Gasket
10	822630	1	31-1/4" Main Door Assembly
11	110006	1	1/2" Black Strapping Tape
12	345479	1	Bottom Front Trim Piece (black)
13	150319	3	#10-32 x 1/2" TORX PLUS® Screw (black)
14	801789	1	Left-Hand Main Door Switch Assembly 37-1/4" Door (includes illus. nos. 14 through 19)
15	150006	2	#6-32 x 7/8" Phillips Screw
16	137005	1	Main Door Switch
17	153010	2	#6 Internal Star Washer
18	152013	2	#6-32 Hex Nut
19	150201	2	#10-32 x 1/4" Phillips Screw
20	345023	1	Front Panel Middle Trim (black)
21	150319	4	#10-32 x 1/2" TORX PLUS® Screw (black)

# Coin Box Assembly, Vault and Coin Chute

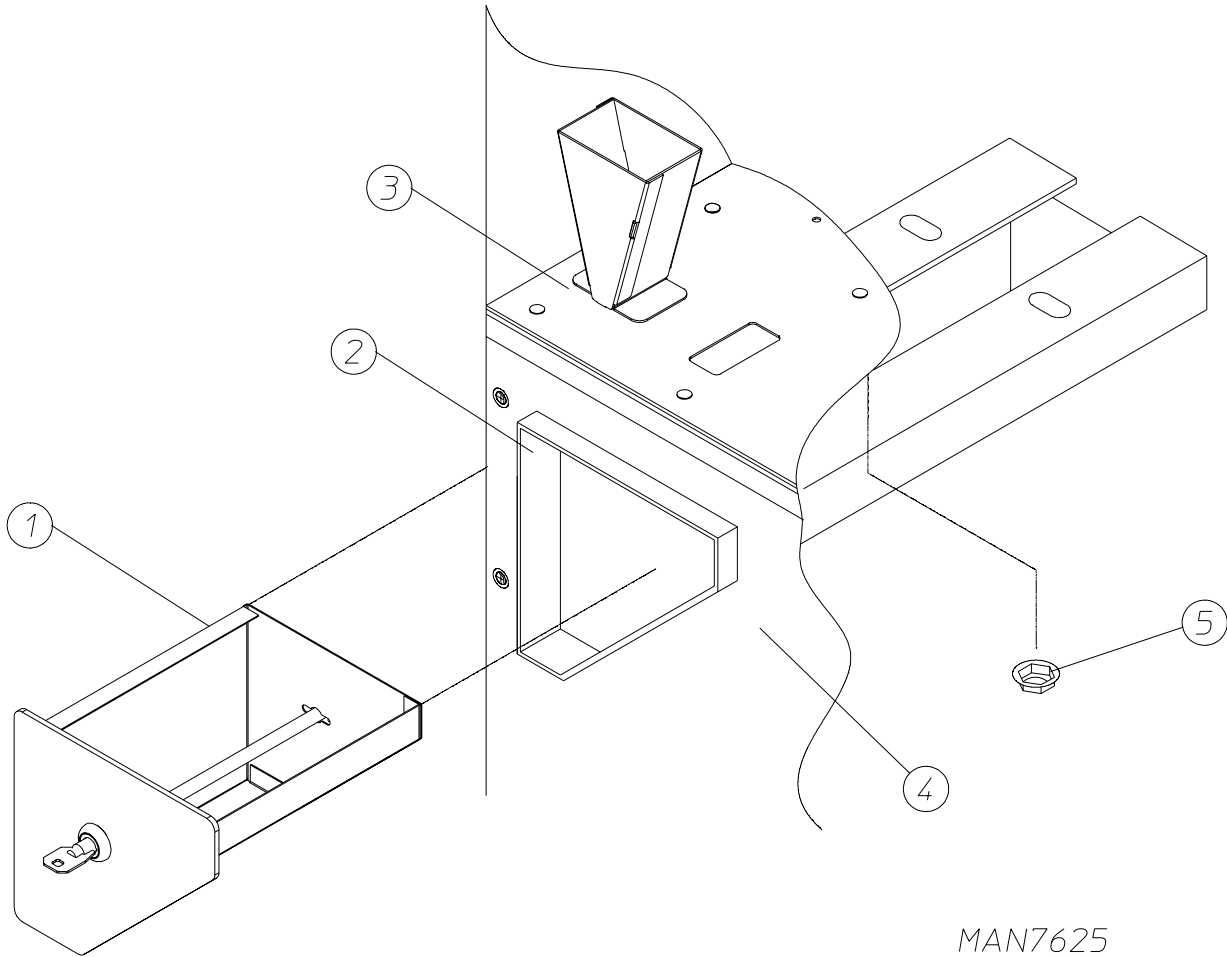

MAN7625

<u>Illus. No.</u>	<u>Part No.</u>	<u>Qty.</u>	<u>Description</u>
1	845789	1	Coin Box Assembly (black)
	160058	1	Coin Box Lock ONLY
	182622	1	Key ONLY (specify key number when ordering)
2	845792	1	Coin Vault
3	845791	1	Coin Chute Assembly
4	_____	-	<b>Refer to page 5</b>
5	152014	4	1/4-20 Free Spin Nut

# Tumbler and Basket Support and Hi-Limit Assembly

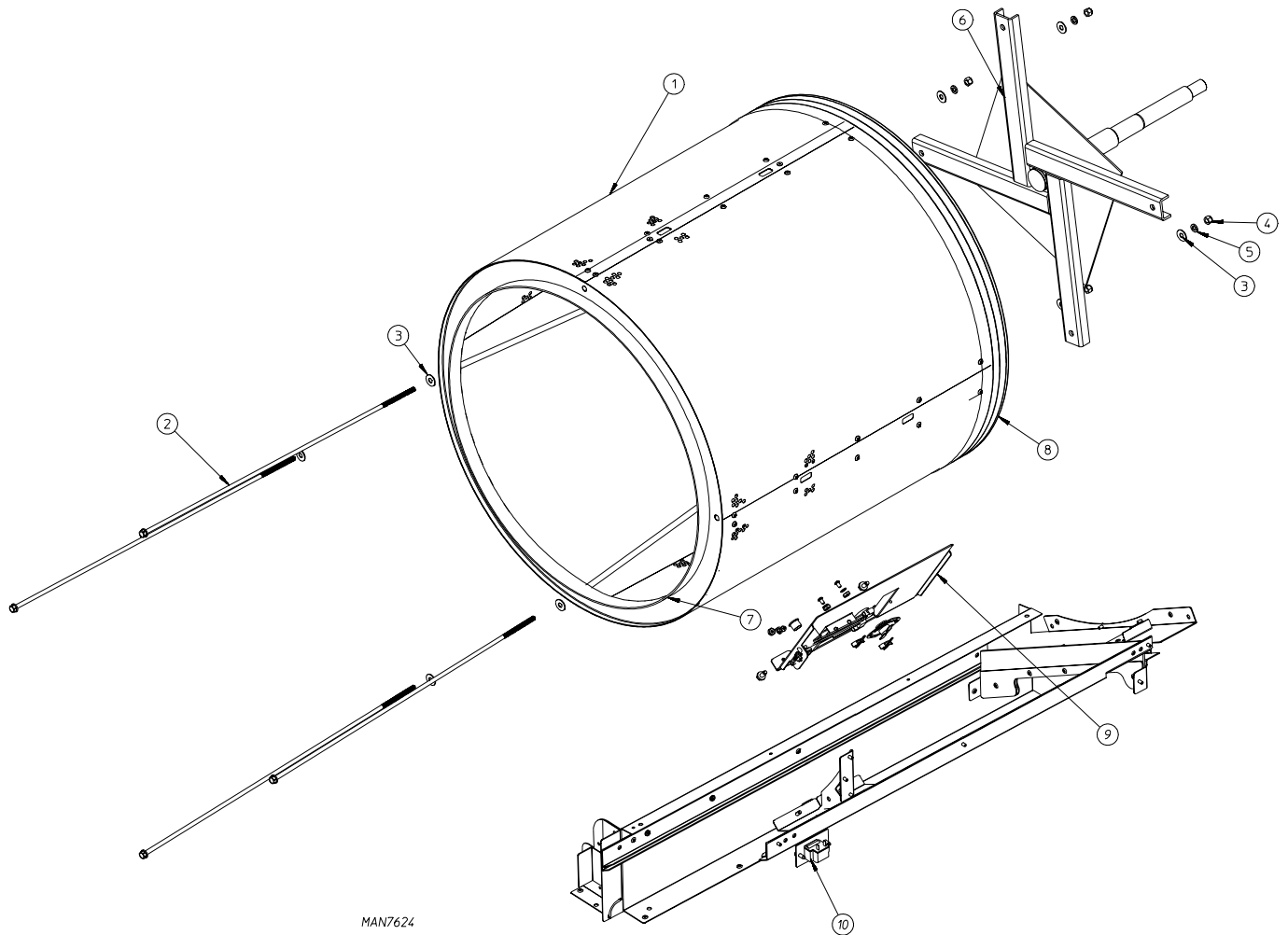

<u>Illus. No.</u>	<u>Part No.</u>	<u>Qty.</u>	<u>Description</u>
1	845754	1	Tumbler and Support Assembly Complete with Felt Collar (includes illus. nos. 1 through 8)
	845753	1	Tumbler ONLY without Felt Collar
2	100915	4	3/8-16 x 31-1/8" Hex Head Tie Rod
3	153004	8	3/8" x 1" Flat Washer
4	152027	4	3/8"-16 Nylon Insert Lock Nut
5	153005	4	3/8" Split Lock Washer
6	845752	1	Tumbler Support ONLY
7	115917	1	Tumbler Front Felt Collar
	401010	1	3M Mastic
8	116001	1	Rear Tumbler Felt
	401010	1	3M Mastic
9	—	—	Microprocessor Temperature Sensor Assembly <b>(refer to Microprocessor Temperature Sensor on page 8)</b>
10	122002	1	Lint Drawer Switch

# Microprocessor Temperature Sensor Bracket Assembly

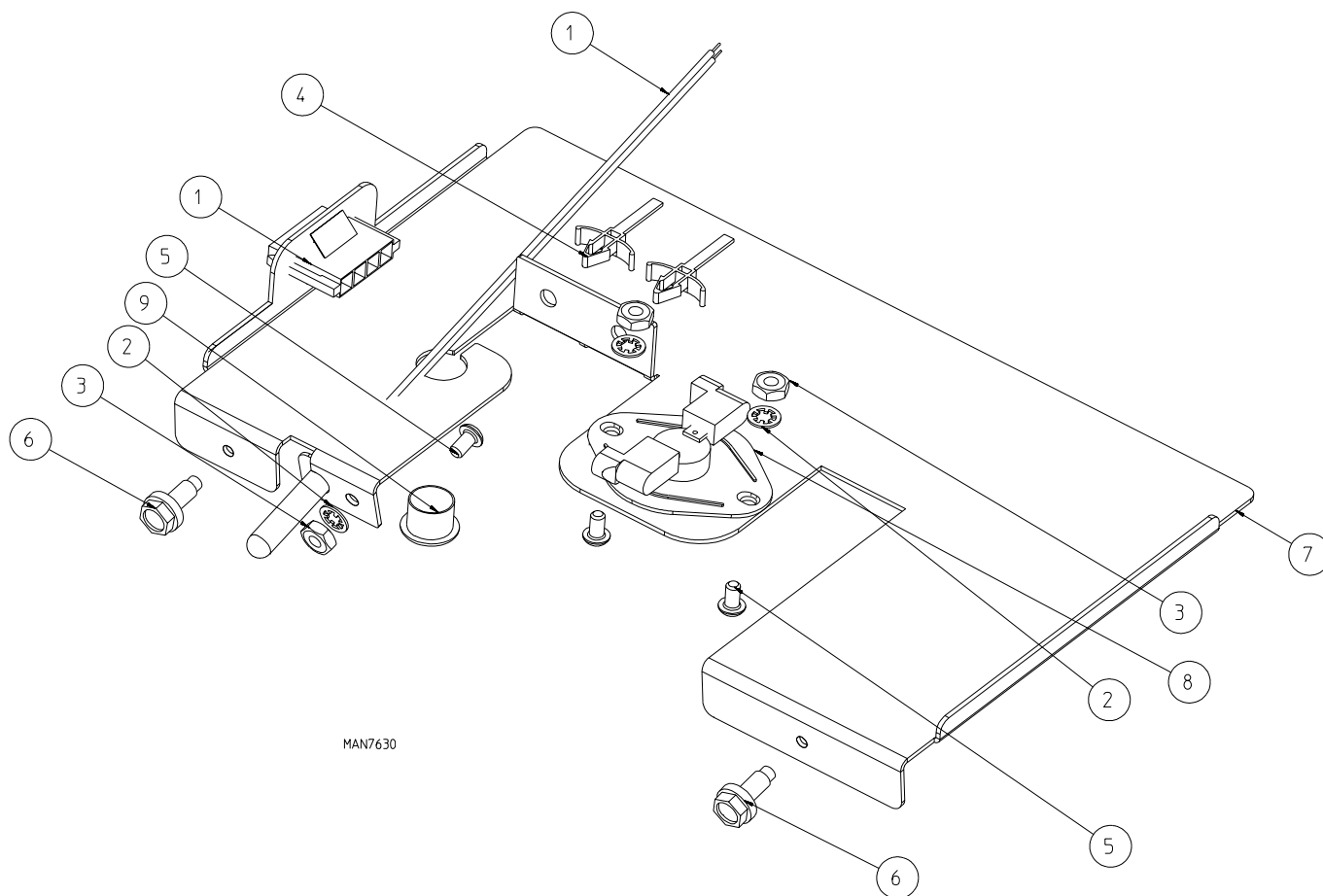

Illus. No.	Part No.	Qty.	Description
1	845036	1	Microprocessor Temperature Sensor ONLY (for models mfd. as of October 6, 2008)
	852321	1	Microprocessor Temperature Sensor ONLY (for models mfd. prior to October 6, 2008)
2	153010	3	#6 Internal Star Washer
3	152000	3	#6-32 Hex Nut
4	121494	2	3/16" Push Mount Wire Tie
5	150005	3	#6-32 x 1/4" Phillips Screw
6	150300	2	#10-16 x 1/2" Hex TEX Screw
7	845855	1	Microprocessor Temperature Sensor Bracket Assembly Complete (for models mfd. as of October 6, 2008)
	845847	1	Microprocessor Temperature Sensor Bracket Assembly Complete (for models mfd. between February 4, 2008 and April 22, 2008)
	845852	1	Microprocessor Temperature Sensor Bracket Assembly Complete (for models mfd. between April 22, 2008 and October 5, 2008)
	819871	1	Microprocessor Temperature Sensor Bracket Assembly Complete (for models mfd. prior to February 4, 2008)
8	130112	1	225° Automatic Thermostat
9	121300	1	Open / Closed Bushing



# Locking Lint Drawer Assembly

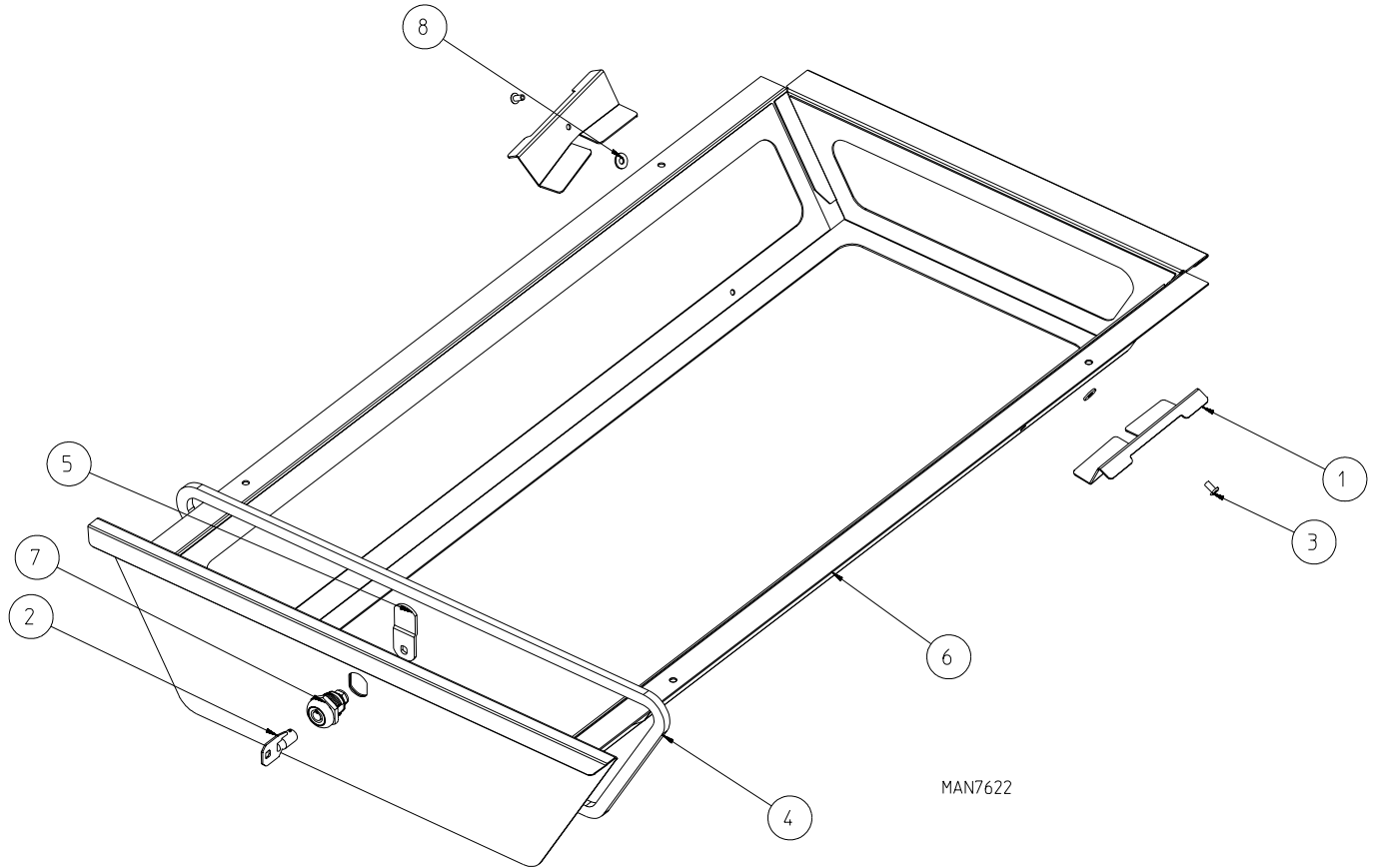

Illus. No.	Part No.	Qty.	Description
1	345187	2	Lint Screen Stop
2	160140	1	Key ONLY for XX4451
3	154200	2	5/32" Rivet
4	117607	4	1/4" x 3/8" Poron Foam
5	160014	1	1/16" Offset x 1-1/2" Cam
6	845765	1*	Locking Lint Drawer Assembly with Lock (includes illus. nos. 1 through 8)
	845803	1*	Lint Drawer Assembly with No Lock (includes illus. nos. 1, 2, 4 through 6, and 8)
7	160039	1	Lint Drawer Lock with Cam with No Key
8	153000	2	#8 Washer

\* Specify color when ordering.

# Tumbler Bearing Support Assembly

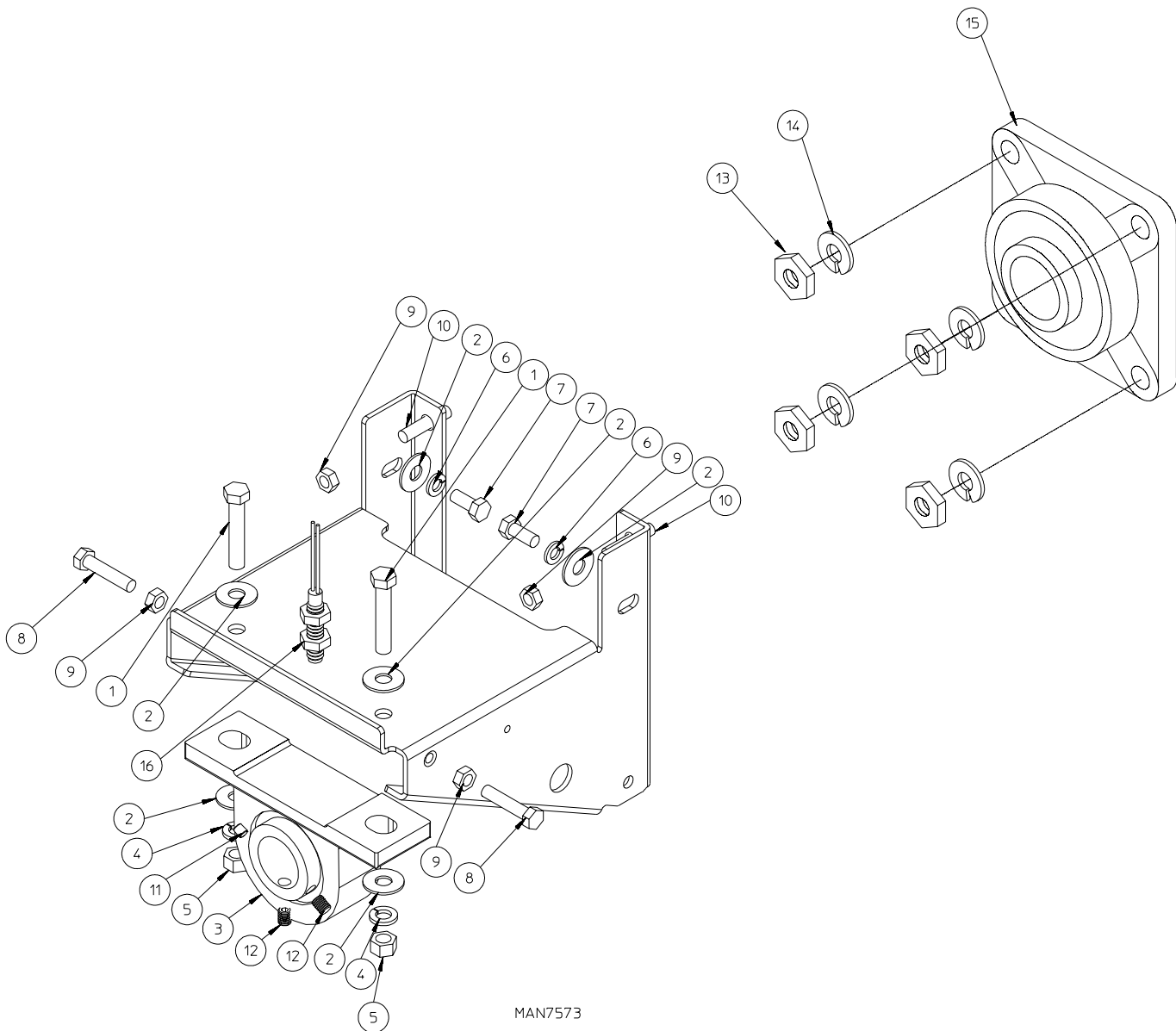

MAN7573

Illus. No.	Part No.	Qty.	Description
1	150601	2	3/8-16 x 2" H.H. Tap Bolt
2	153004	8	3/8" x 1" OD Flat Washer
3	880779	1	1-3/8" Pillow Block Bearing with Rotational Sensor
4	153005	2	3/8" Split Lock Washer
5	152005	2	3/8-16 Hex Nut
6	153002	4	5/16" Split Lock Washer
7	150501	4	5/16-18 x 3/4" Tap Bolt
8	150621	2	5/16-18 x 1-1/2" Tap Bolt
9	152004	4	5/16-18 -18 Hex Nut
10	150610	2	5/16-18 1-1/2" Allen Setscrew
11	170608	1	.25" x .25" Magnet
12	154321	2	5/16-24 x 3/8" Allen Setscrew
13	152050	4	9/16-12 Hex Nut
14	153025	4	9/16" Lock Washer
15	880220	1	1-3/4" Flange Bearing
16	818370	1	Rotational Sensor

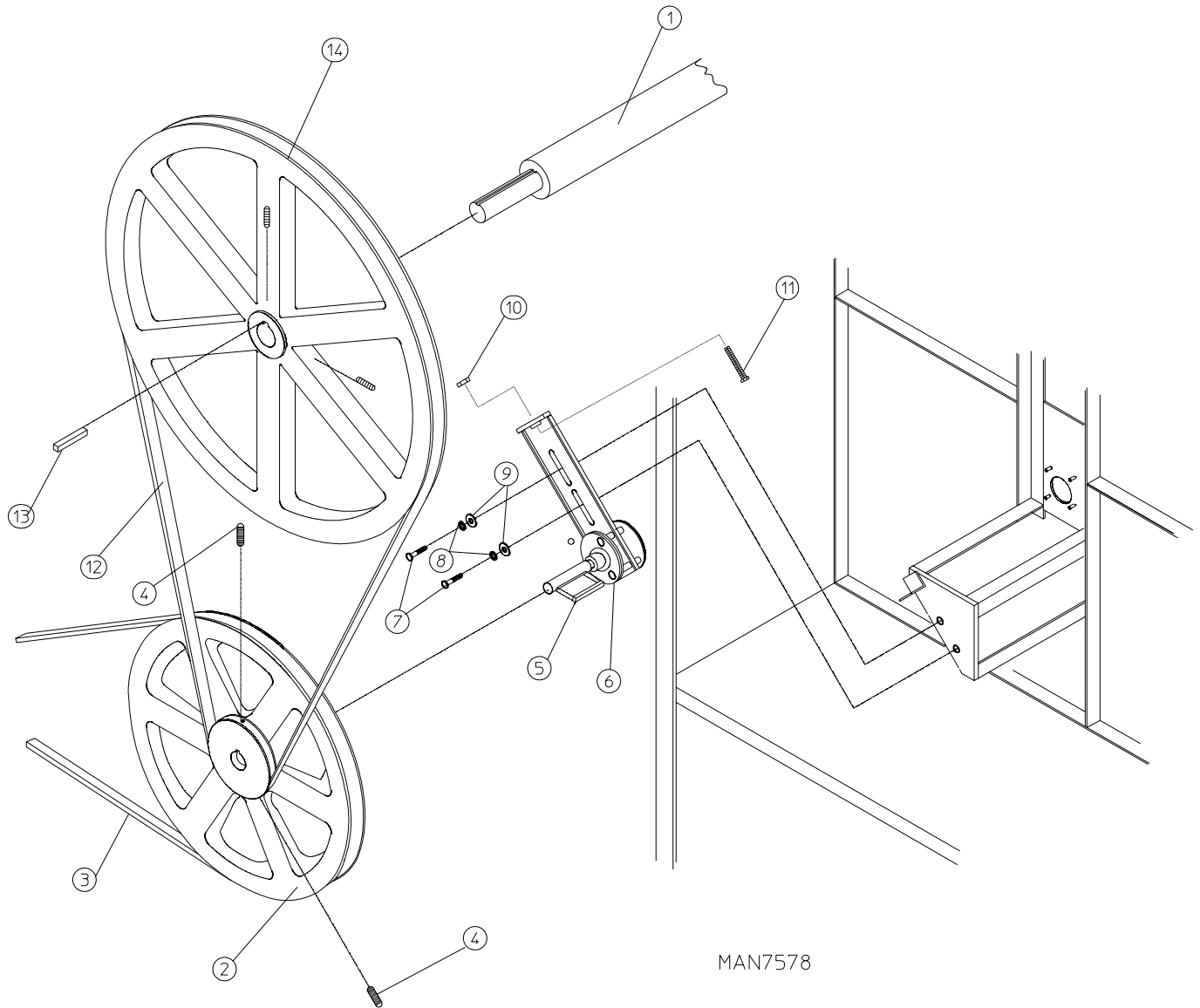

MAN7578

Illus. No.	Part No.	Qty.	Description
1	—	1	Tumbler Support <b>(refer to Tumbler / Support Assembly on page 7)</b>
2	101129	1	9" x 2-1/2" Compound Pulley
3	100181	1	4L450 V-Belt
4	154301	2	5/16-18 x 5/16" Allen Cone Point Setscrew
5	100705	1	3/16" x 3/16" x 1-3/8" Key
6	882777	1	Steel Idler Assembly
7	150617	2	3/8-16 x 1" Hex Head Machine Screw
8	153005	2	3/8" Lock Washer
9	153004	2	3/8" Flat Washer
10	152004	1	5/16-18 Hex Nut
11	150509	1	5/16-18 x 3" Hex Head Machine Bolt
12	100147	1	5L630 V-Belt
13	100713	1	1/4" x 1/4" x 7/8" Key
14	101100	1	18" Pulley (tumbler)

# Totally Enclosed, Fan-Cooled Motor Mount Assembly

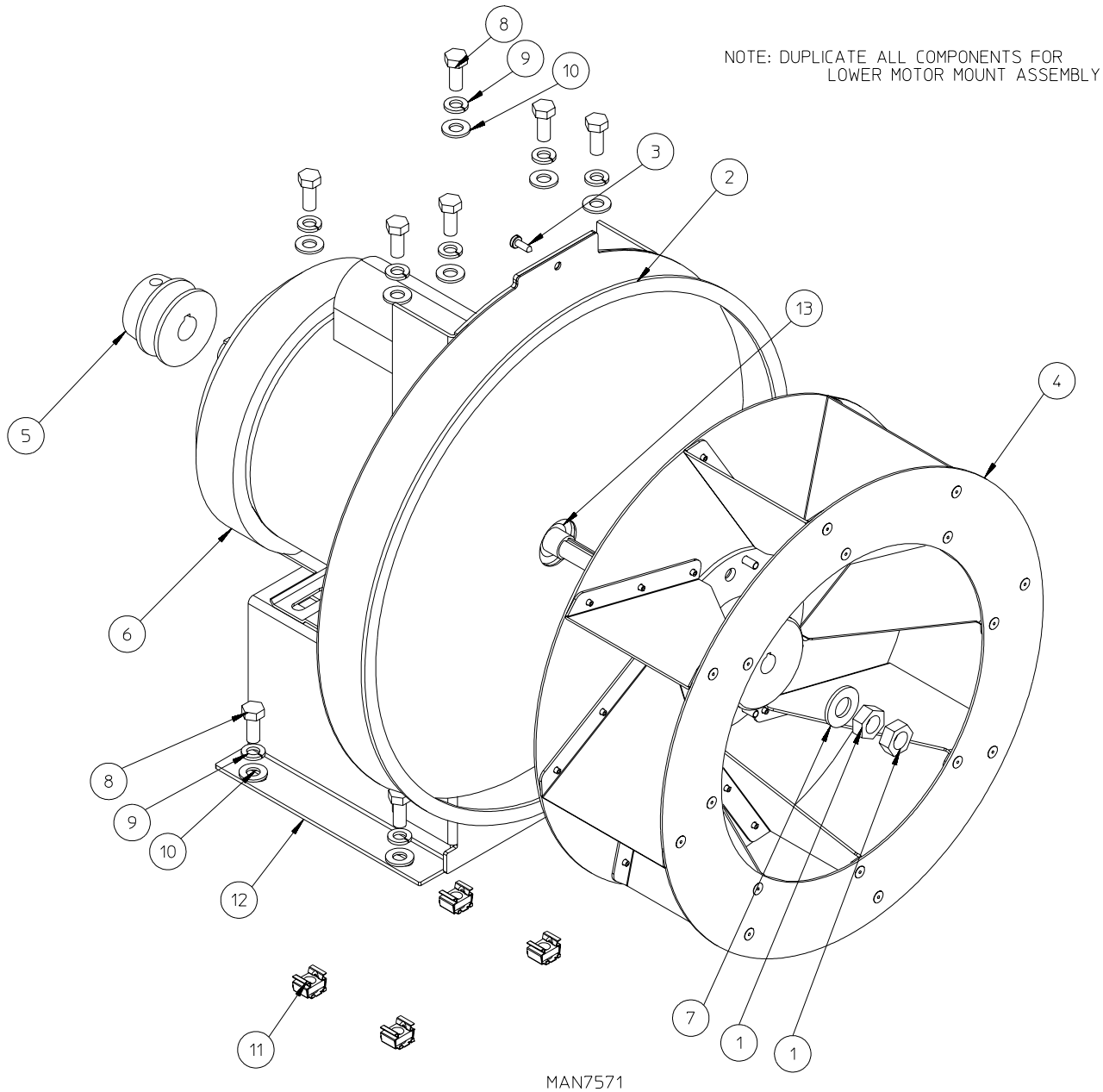

Illus. No.	Part No.	Qty.	Description
1	152006	2	1/2-20 L.H. Jam Nut
2	117604	1	1/8" Thk x 3/8" W Neo. Sponge Tape
3	150331	1	#8-18 x 1/2" T-20 TORX®
4	845783	1	13" Riveted Impellor 1/2" Bore
5	101132	1	2.0 OD x 5/8" Motor Pulley
6	100069	1	3/4" 115/230/60/1 with Plug
7	153050	1	1/2" x 1-1/16" Flat Washer
8	150501	8	5/16-18 x 3/4" Tap Bolt
9	153002	8	5/16" Split Lock Washer
10	153001	8	5/16" Flat Washer
11	154000	4	5/16-18 Tinnerman Clip
12	845935	1	3/4 hp Motor Mount Assembly 115/230/60/1-Phase
	845758	1	Motor Mount
13	116010	1	3" x 3" Felt Motor Seal

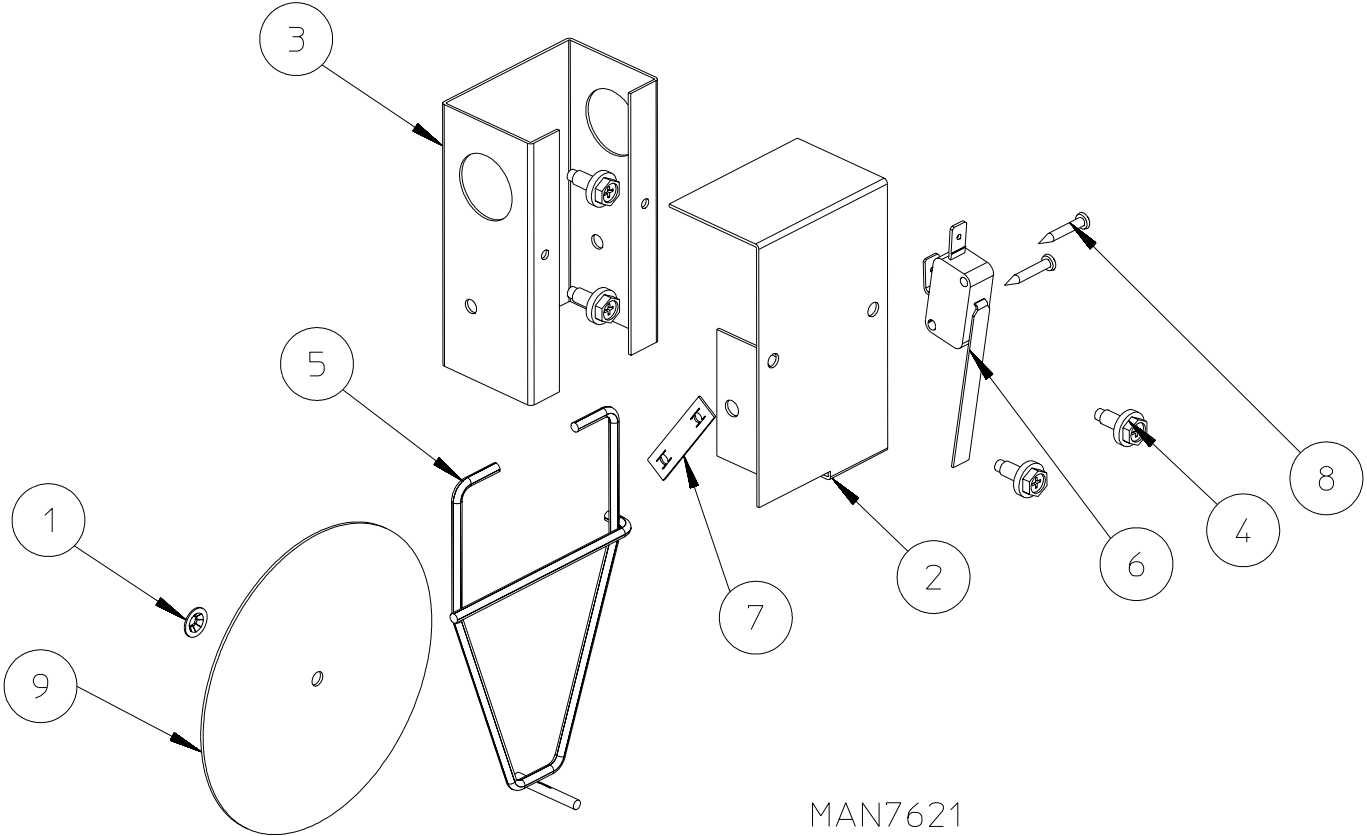

MAN7621

<u>Illus. No.</u>	<u>Part No.</u>	<u>Qty.</u>	<u>Description</u>
1	154002	1	1/8" Push-On Fastener
2	802799	1	Sail Switch Box Top
	802801	1	Sail Switch Assembly (includes illus. nos. 1 through 9)
3	319200	1	Sail Switch Box (includes illus. nos. 1 through 9)
4	150309	4	#10-16 x 1/2" Hex Head Screw
5	105500	1	Sail Switch Rod
6	122200	1	Sail Switch
7	154004	1	Twin Speed Nut
8	150303	2	#4 x 3/4" Phillips Screw
9	319202	1	Sail Switch Flat Damper

# Natural Gas Burner Assembly

NOTE: DUPLICATE ALL COMPONENTS FOR  
LOWER GAS VALVE/BURNER ASSEMBLY

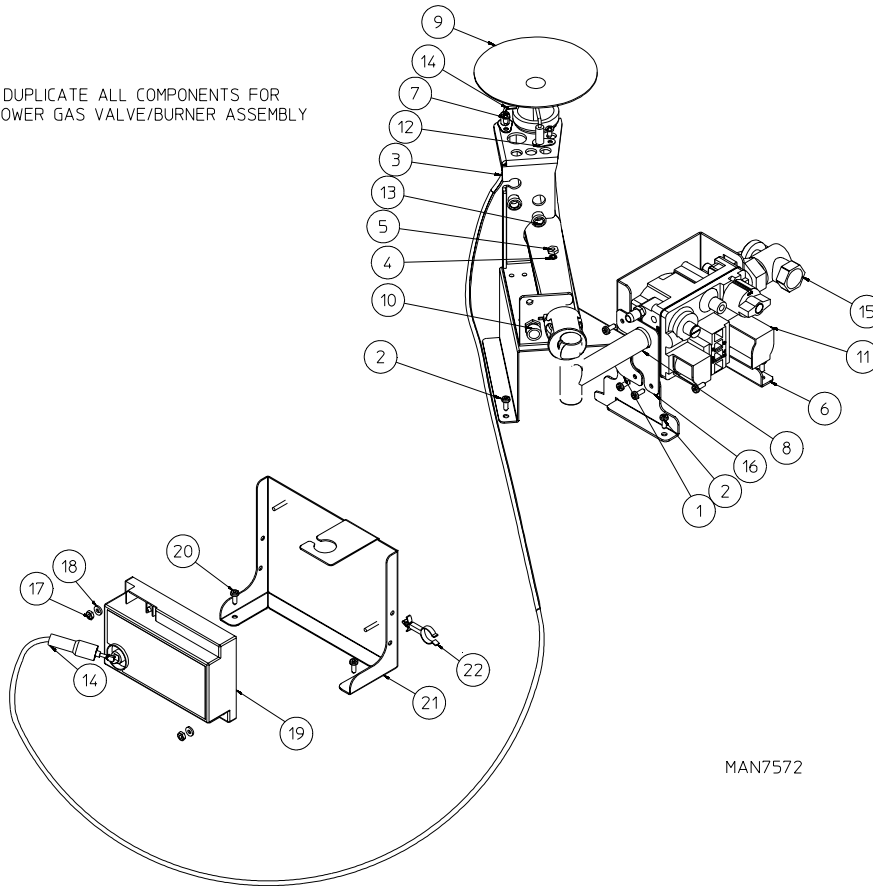

MAN7572

<u>Illus. No.</u>	<u>Part No.</u>	<u>Qty.</u>	<u>Description</u>
1	845933	1	Natural Gas Burner Assembly (includes illus. nos. 1 through 16)
	845934		Burner Tube Bracket Support
2	150331	7	#8-18 x 1/2" TORX® Screw
3	318009	1	Burner Tube Bracket
4	153012	1	#8 Star Washer
5	152001	1	#8-32 Hex Nut
6	345085	1	Gas Valve Bracket
7	150301	2	#8-18 x 7/16" Phillips Screw
8	141235	1	1/2" Swage Manifold Port
9	141131	1	Upshot Burner Assembly
10	140834	1	#5 Burner Orifice (natural gas) ONLY
	140818	1	#31 Burner Orifice Liquid Propane ONLY
	887162	1	Direct Spark Ignition Liquid Propane Conversion Kit
11	128927	1	1/2" 24 VAC Redundant (natural gas) Gas Valve
12	128918	1	Flame Sensor
13	121300	2	Open / Closed Bushing
14	829998	1	Fenwal High Voltage Cable Assembly
15	141320	1	1/2" Full Port Valve with Tailpiece
16	345108	1	Gas Valve Manifold Support
17	152013	2	#6-32 Hex Nut
18	153017	2	#6 Washer
19	887133	1	Fenwal Direct Spark Ignition Module Gray with 3 Tries
20	150331	2	#8-18 x 1/2" Pan Head TORX® Screw
21	845756	1	Direct Spark Ignition Module Mounting Plate Assembly
22	121502	1	1/2" Wire Standoff

# Single-Phase (1Ø) Top Motor Electrical Relay Panel Assembly

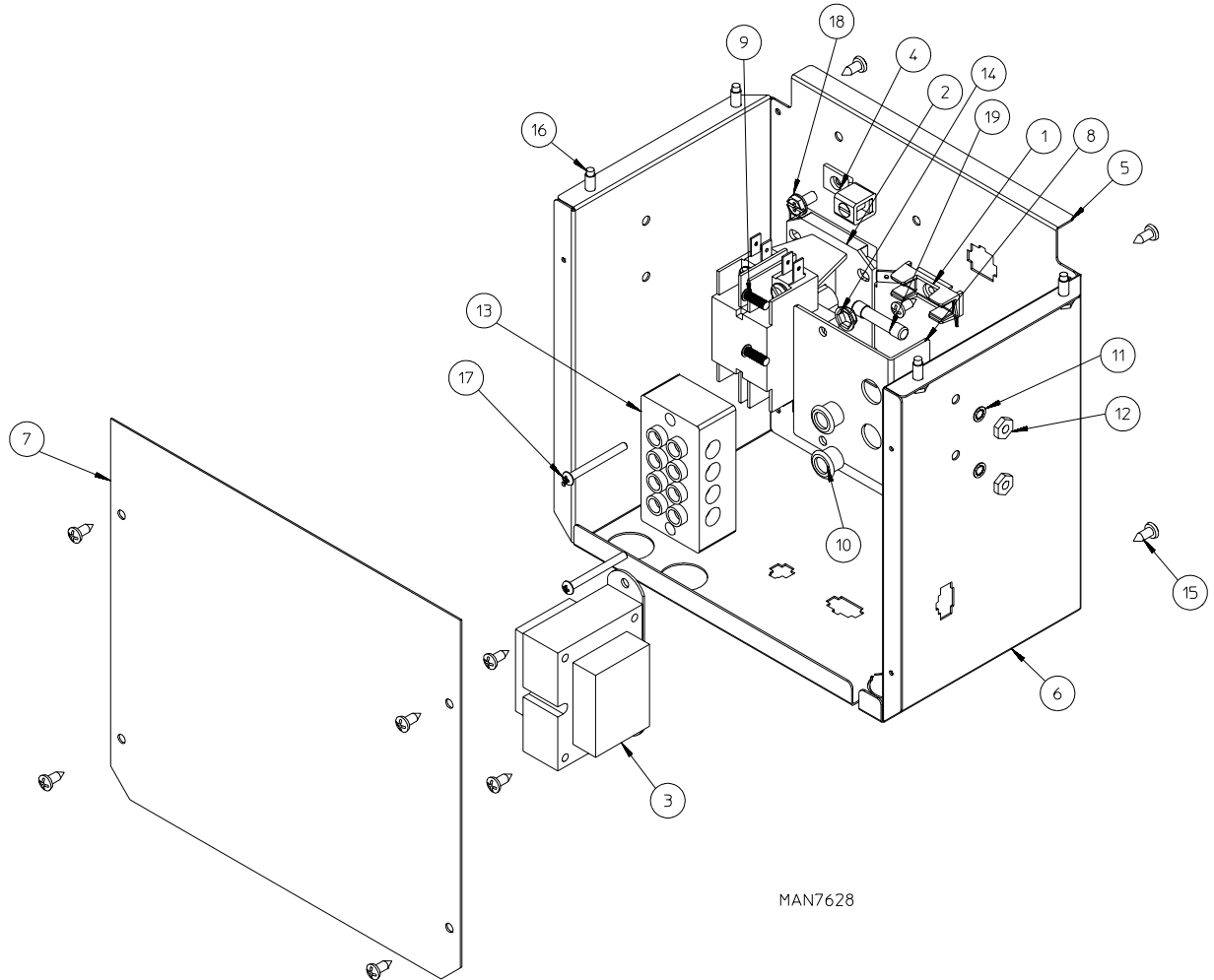

Illus. No.	Part No.	Qty.	Description
1	136008	1 or 2	Fuse Holder
2	132475	1	Double Pole 24 VAC Motor Contactor
3	855255	1	Transformer Assembly (120V)
	855256	1	Transformer Assembly (208-240V)
4	121010	1	Terminal Lug
5	315293	1	Rear Wire Box Back Plate
6	315294	1	Rear Wire Box Body
7	315300	1	Rear Wiring Box Cover
8	353142*	1	Power Block Mounting Bracket
9	153528*	2	#8-32 x 1/2" Self-Clinching Stud
10	121300*	2	Open / Closed Bushing
11	153012*	2	Star Washer
12	152001*	2	#8-32 x 3/8" Hex Nut
13	120701*	1	4-Position Terminal Block
14	151000*	2	#6-32 Pal Nut
15	150301	11	#8-18 x 7/16" Phillips Pan Head TEK Screw
16	150300	4	#10-16 x 1/2" Hex Washer TEK Screw
17	150009	2	#6-32 x 1-1/2" Phillips Machine Screw
18	120910	1	Green Ground Screw
19	136049	1 or 2	3/4-amp Slo-Blo Fuse

\* Parts for top electric box only.

# Single-Phase (1Ø) Bottom Motor Electrical Relay Panel Assembly

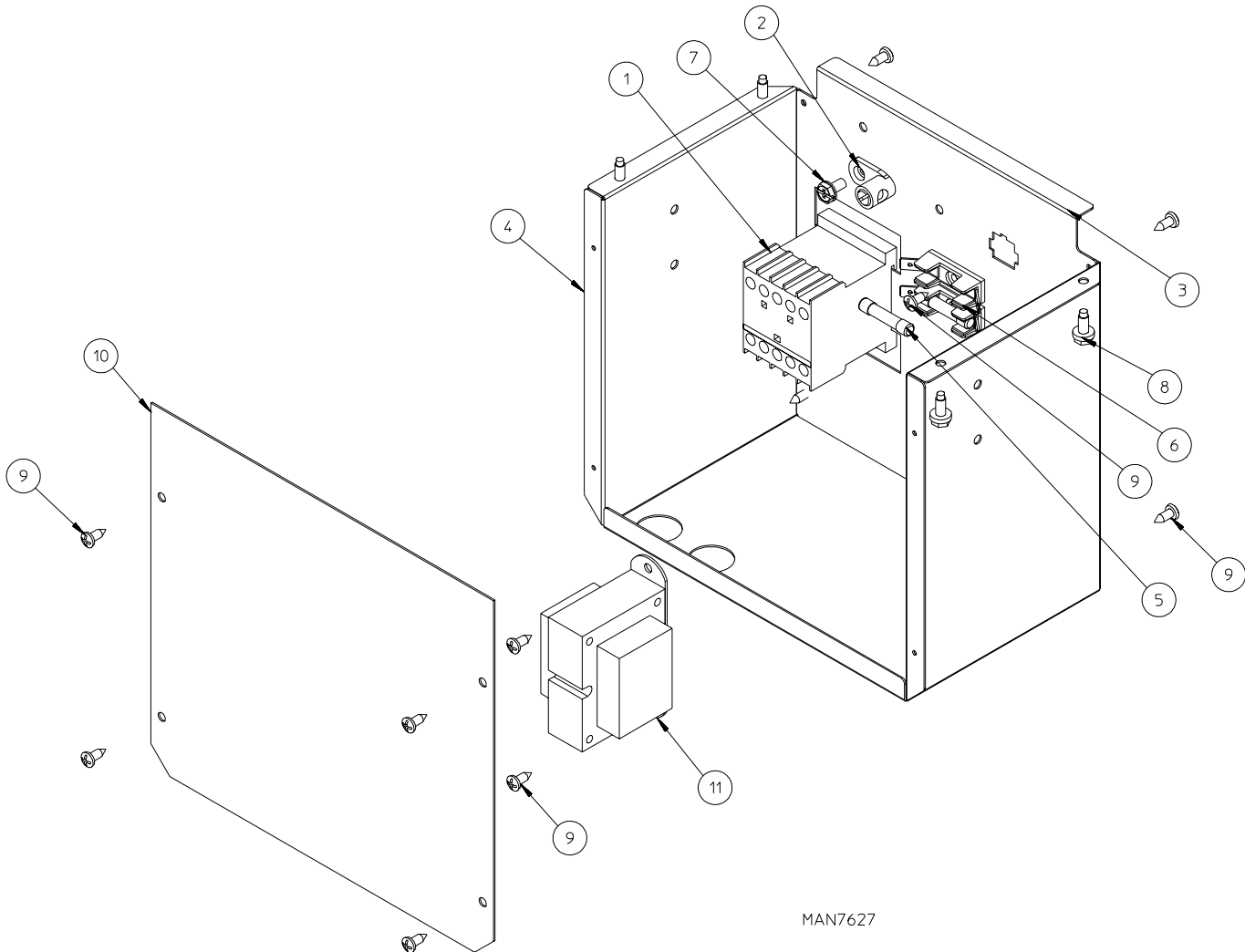

<u>Illus. No.</u>	<u>Part No.</u>	<u>Qty.</u>	<u>Description</u>
1	136008	1	Fuse Holder
2	132475	1	Double Pole 24 VAC Motor Contactor
3	136049	1	3/4-amp Slo-Blo Fuse
4	121010	1	Terminal Lug
5	315293	1	Rear Wire Box Back Plate
6	315294	1	Rear Wire Box Body
7	315300	1	Rear Wiring Box Cover
8	120910	1	Green Ground Screw
9	150300	4	#10-16 x 1/2" Hex Washer TEK Screw
10	150301	11	#8-18 x 7/16" Phillips Pan Head TEK Screw
11	855255	1	Transformer Assembly (120V)



# 3-Phase (3Ø) Top Motor, Electrical Relay Panel Assembly

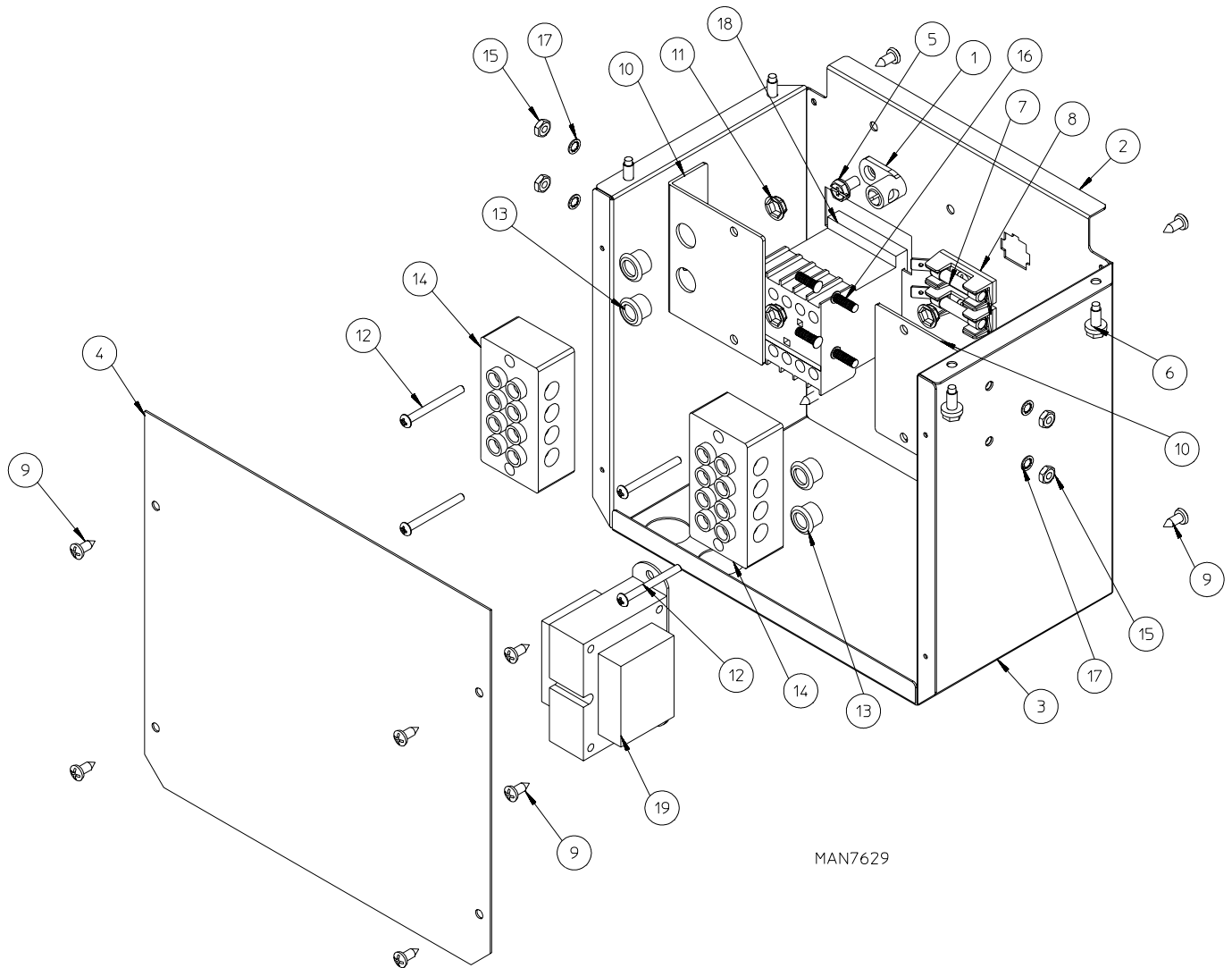

<u>Illus. No.</u>	<u>Part No.</u>	<u>Qty.</u>	<u>Description</u>
1	121010	1	Terminal Lug
2	315293	1	Rear Wire Box
3	315294	1	Rear Wire Box Body
4	315300	1	Rear Wiring Box Cover
5	120910	1	Green Ground Screw
6	150300	4	1/2" Hex TEK Screw
7	136057	2	1/2-amp Slo-Blo Fuse
8	136008	2	Fuse Holder
9	150301	12	7/16" Phillips TEK Screw
10	353142	1	Power Block Mounting Bracket
11	151000	2	Pal Nut
12	150009	4	1-1/2" Phillips Screw
13	121300	4	Open / Closed Bushing
14	120701	1	4-Position Terminal Block
15	152001	2	3/8" Hex Nut
16	153528	4	1/2" Clinch Stud
17	153012	4	#8 Internal Star Washer
18	132495	1	Three Pole 24 VAC Motor Contactor
19	855256	1	Transformer Assembly (208-240V)

## 3-Phase (3Ø) Bottom Motor, Electrical Relay Panel Assembly

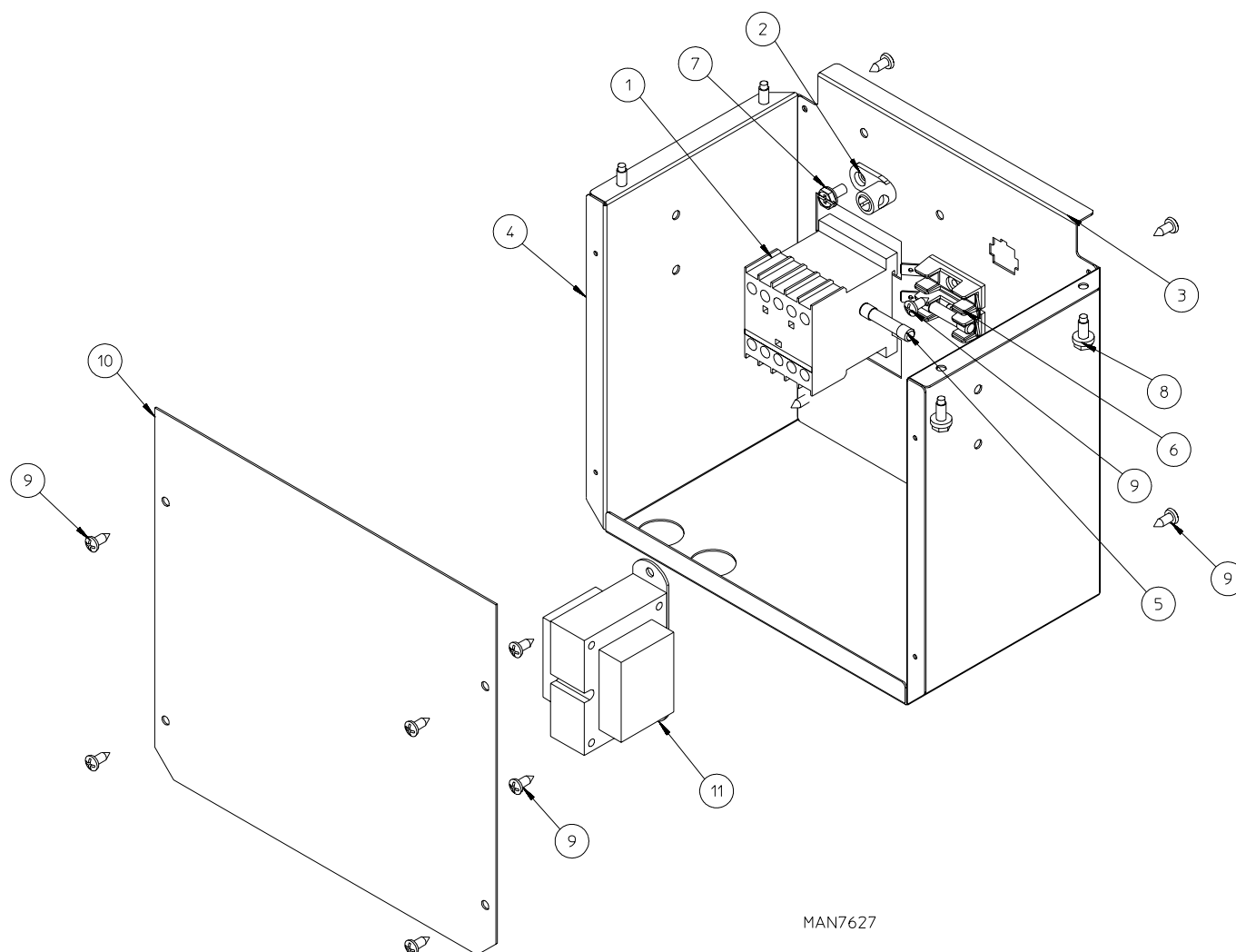

Illus. No.	Part No.	Qty.	Description
1	132495	1	Three Pole 24 VAC Motor Contactor
2	121010	1	Terminal Lug
3	315293	1	Rear Wire Box Back Plate
4	315294	1	Rear Wire Box Body
5	136057	2	1/2-amp Slo-Blo Fuse
6	136008	2	Fuse Holder
7	120910	1	Green Ground Screw
8	150300	4	1/2" Hex TEK Screw
9	150301	12	3/16" Phillips TEK Screw
10	315300	1	Rear Wiring Box Cover
11	885256	1	Transformer Assembly (208-240V)

# Exhaust, Back Guard, and Burner Assembly

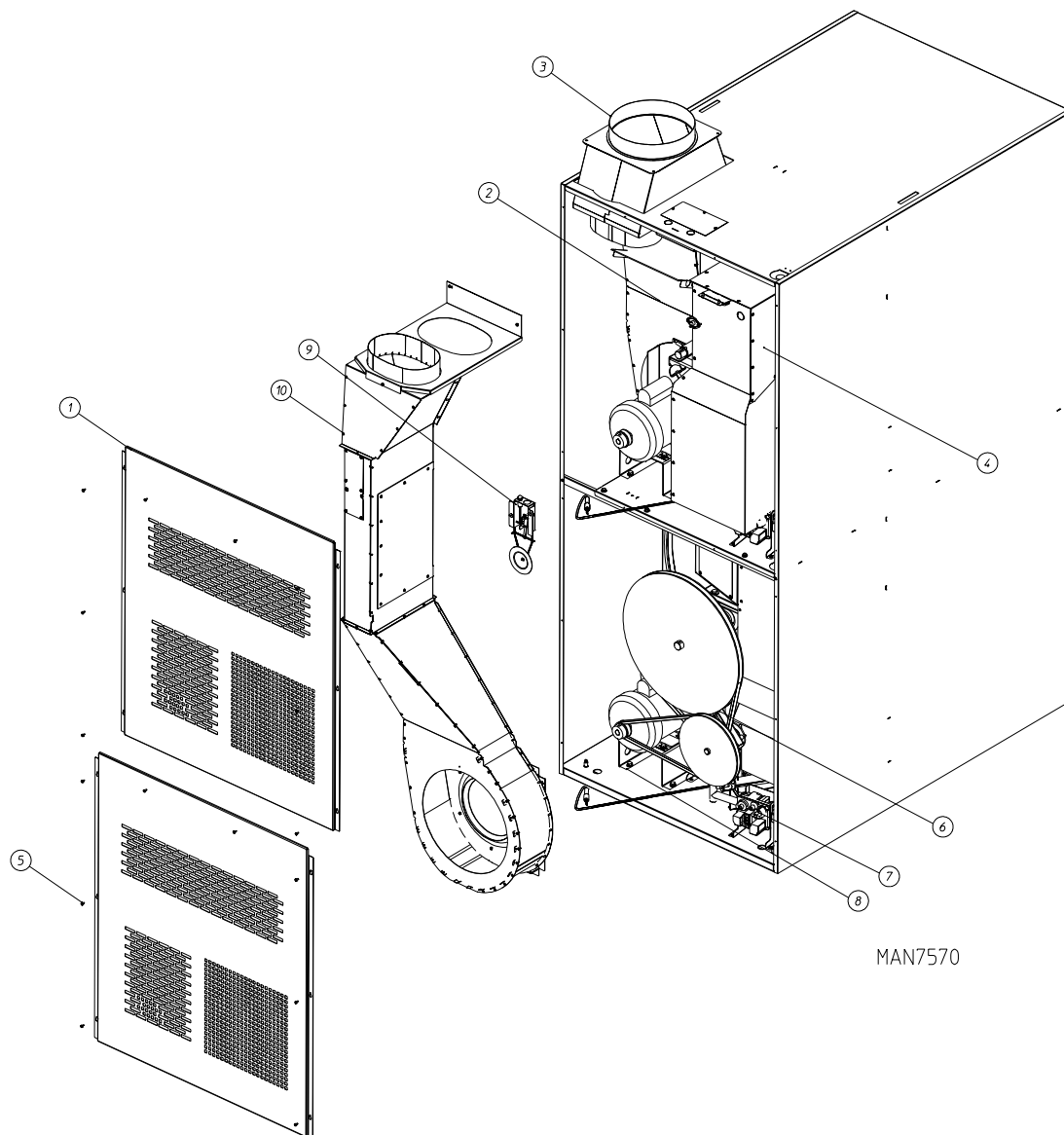

MAN7570

Illus. No.	Part No.	Qty.	Description
1	345211	1	Back Guard
2	130403	1	330° Burner Hi-Limit
3	845822	1	10" Exhaust Adapter
4	845773	1	Gas Burner Assembly
5	150301	6	#8-18 x 7/16" Phillips Screw
6	—	—	Drive and Idler Pulleys (refer to <b>Drive and Idler / Pulley on page 11</b> )
7	—	—	Natural Gas Burner Assembly (refer to <b>Natural Gas Burner Assembly on page 14</b> )
8	—	—	Motor Mount Assembly (refer to <b>Motor Mount Assembly on page 12</b> )
9	—	—	Sail Switch Assembly (refer to <b>Sail Switch Assembly on page 13</b> )
10	—	*	Exhaust Assembly

\* Contact factory for any parts.

