

Section 7

Parts Data

Thoroughbred 600

Accessories

Models	WCN40AA	220-240	volts	60hz.	Single Phase
	WCN40AB	208-240	volts	60hz.	Three Phase

MODELS
WCN40
A A
A B

Part Number	Description		
Grip-O-Matic #1045	Puller to Remove Pulley and Bearing Housing from Shaft on T-600		
9732-139-002	Kit, Door Gasket Expander (large)		
9732-139-001	Kit, Door Gasket Expander (small)		
9990-027-011	Hose, Water Supply (furnished) 3/8" I.D. x 48"	2	2
9990-027-013	Hose, Water Supply (optional) 5/8" I.D. x 48"		
8641-242-000	Washer, Inlet Hose (furnished)	2	2
9565-003-001	Strainer, Inlet Hose (furnished)	2	2
9242-417-001	Drain hose 10 ft. length x 2-1/4" I.D.		
9242-417-003	Drain hose 10ft. length x 3" I.D.		
8641-586-002	Bevel Washer for 5/8" bolt used in installations using angle iron bases		
8641-586-003	Bevel Washer for 3/4" bolt used in installations using angle iron bases		
9732-139-001	Kit , Door Gasket Expander (large)		
9732-139-002	Kit , Door Gasket Expander (small)		
9732-140-001	Manual Operation Kit		
9539-474-001	Switch, Blk/Red (included in kit)		
9539-474-002	Switch, Blk/Wht (included in kit)		
8545-055-002	Electrical Probe 100-600VAC		
8545-055-001	Electrical Probe 24-90 VAC		
8538-151-001	Sealing compound		
8545-051-002	TORX#20		
8545-051-003	Special Tool For Removing Coin Acceptor Mounting Screws. (T-10 Torx)		
9475-002-002	Flow Restrictors (in dispenser)		

CABINET AND FRONT PANEL GROUP

Key	Part Number	Description	MODELS	
			WCN40	
			A	A
			A	B
1	9989-449-001	Panel, Side (Left or Right)- Stainless.....	2	2
2	9545-018-013	Screw, (Side Panel to Base)	8	8
2	8640-414-006	Nut 8.....	8	8
*	9029-066-001	Bracket, Side Panel	1	1
*	8640-413-002	Nut, Hex #10	2	2
*	9545-008-005	Screw, #10	2	2
3	9454-669-001	Panel Assy, Front	1	1
4	9059-063-002	Band, Edge Protector (mounted to front panel)	1	1
*	8640-399-005	Nut, Spring- To Control Panel	2	2
*	9545-008-024	Screw, Hex- To Control Panel	2	2
5	9545-008-014	Screw, Flat Head	2	2
5	8641-585-001	Washer, Finish	2	2
*	8640-399-008	Nut, Spring	2	2
*	9545-008-023	Screw, Fillister Head Guide	2	2
6	8502-624-002	Label, Door Opening	1	1
7	9989-453-001	Panel, Control (Mounts Nameplate)	1	1
*	9545-008-005	Screw, Control Panel Mtg	4	4
8	9412-076-006	Nameplate, Control Panel.....	1	1
9	9454-664-001	Panel, Top	1	1
10	8650-012-003	Lock, Top (w/Key)	1	1
*	9306-025-001	Key, Top-6324	1	1
*	9095-038-001	Cam, Lock Top	1	1
*	8640-426-001	Nut, 9/32	1	1
*	8641-581-008	Washer	1	1
11	9108-097-001	Door, Lower Service	1	1
12	9244-081-002	Handle (bumper guard).....	1	1
*	9545-045-010	Screw (mounting handle)	4	4
13	9545-008-014	Screw, Flat Head	2	2
13	8641-585-001	Washer, Finish	2	2
*	8640-399-008	Nut, Spring	2	2
*	9545-008-023	Screw, Fillister Head Guide Locating Front Panel	2	2
14	9108-095-003	Door, Dispenser	1	1
*	9451-191-001	Pin, Plain SS	2	2
*	9467-025-001	Post, Door Mounting	2	2
*	9545-045-002	Screw, Dispenser Post Mtg	4	4
*	9545-008-012	Screws, Dispenser Mounting	4	4
*	8640-399-007	Nuts, Spring	4	4
*	9086-017-001	Catch, Top Panel	1	1
*	9467-024-001	Top Panel Locator Posts	2	2
*	8640-411-003	Nut, Keps (for top panel locator posts)	2	2
*	9355-001-001	Locator, Panel	2	2
*	9545-008-025	Screw, #10	2	2
15	9732-122-001	Box Assy, Coin (See Coin Handling Group)	1	1
16	9021-001-010	Acceptor, Coin (See Coin Handling Group)	1	1
17	9456-041-007	Plastic Plug 1 1/2 (inside cylinder).....	1	1

* Not Illustrated

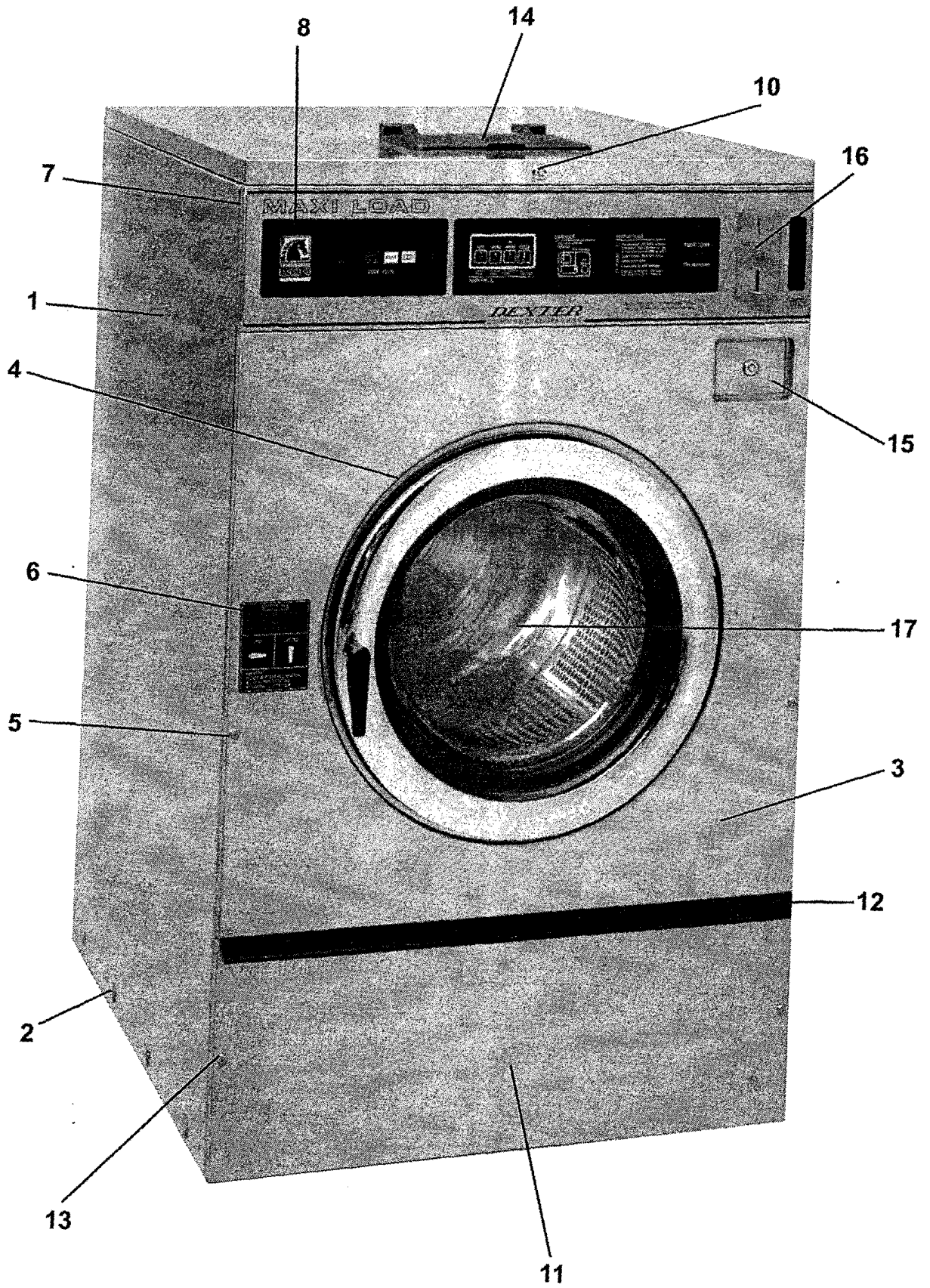

REAR VIEW

Key	Part Number	Description	MODELS	
			WCN40	
			A	A
			A	B
1	9732-127-005	Drive Motor, 1 Phase 60 HZ (see kit list)	1	
1	9732-127-006	Drive Motor, 3 Phase 60 HZ (see kit list)		1
2	9497-222-004	Rod, Motor Mtg	1	1
3	9545-029-005	Bolt (motor mounting rod)	1	1
3	8641-582-014	Lockwasher	1	1
4	9076-052-002	Collar, Shaft (w/set screws)	3	3
5	9453-170-002	Pulley, Motor	1	1
*	9545-028-013	Screw, set	2	2
6	9453-168-003	Pulley, Driven	1	1
7	9545-060-001	Screw, Pulley to Shaft	1	1
8	8641-581-032	Washer, Flat	2	2
7	8641-582-018	Lockwasher	1	1
9	9040-076-005	Drive Belt	2	2
11	9081-123-001	Channel, Rear	1	1
10	9545-008-026	Screw	4	4
*	8640-399-004	Nut, Spring	4	4
12	9242-449-002	Hose, Overflow	1	1
13	8654-029-000	Clamp, Hose spring type	2	2
*	9989-446-001	Panel Assy., Back	1	1
*	9545-008-026	Screw	8	8
*	8640-399-004	Nut, Spring	6	6
14	9545-030-002	Screw, to Base bottom	3	3
15	9242-175-002	Hose, Pressure Switch	1	1
*	8654-117-015	Clamp, Pressure Sw. Hose 1 WORM TYPE	1	1
16	5198-211-004	Circuit Breaker, 1.5 amp	1	1
17	9242-458-002	Hose, Vacuum Breaker to Tub	1	1
*	8654-117-014	Clamp, Hose to Vacuum Breaker	1	1
*	8654-117-009	Clamp, Hose to Tub	1	1
18	9029-027-003	Strap, Motor tension	1	1
19	8640-413-002	Nut, Strap to Motor	1	1
19	8641-581-006	Washer	1	1
20	9534-319-002	Spring, Belt Tension	1	1
21	9545-055-001	Bolt, Eye 1/4 -20 X 2 1/2	1	1
22	8640-414-003	Nut, 1/4-20 Elastic Stop	1	1
23	8502-614-004	Label High Voltage	1	1
24	9242-463-003	Hose Overflow 12 1/4 upper	1	1

* Not Illustrated

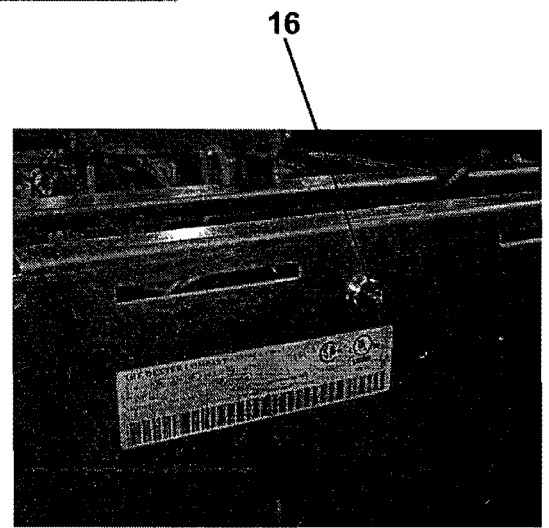
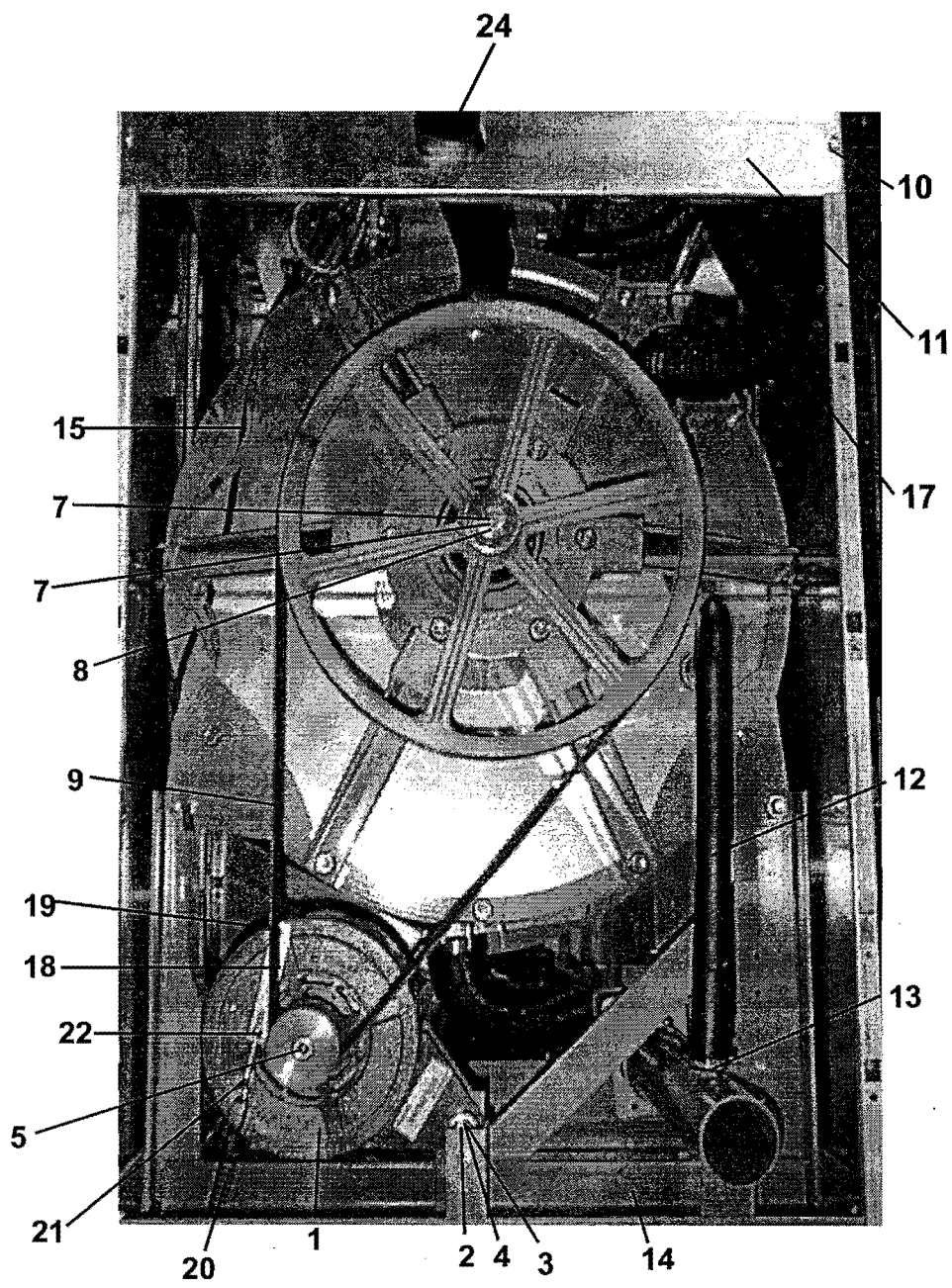

CHASSIS AND DRAIN GROUP

Key	Part Number	Description	MODELS	
			WCN40	
			A	A
			A	B
1	9945-097-002	Base Assy, Frame	1	1
2	9930-136-001	Tub Assy	1	1
3	9967-009-002	Cradle Assy, Tub	1	1
4	9950-050-002	Ring Assy, Tub Mtg-Front	2	2
5	9545-060-003	Bolt, Top Front Ring 5/8 x 3	1	1
5	8640-425-001	Nut	1	1
5	8641-582-018	Lockwasher	1	1
6	9545-060-002	Bolt, 5/8 x 2 1/2 Front Ring to Cradle (double nuts used).....	2	2
6	8640-425-001	Nut, Hex	4	4
7	9950-041-004	Ring Assy., Tub Mtg.- Rear	1	1
8	9545-060-001	Bolt, 5/8 x 1 1/2 Rings to Base (front and rear)	4	4
8	8641-582-018	Lockwasher	4	4
8	8640-425-001	Nut, Hex	4	4
9	9379-187-001	Valve, Drain	1	1
10	9029-052-001	Bracket, Drain Valve	1	1
*	9545-048-001	Screw, Valve to Bracket	1	1
*	8641-581-018	Washer	1	1
11	9545-030-002	Screw, Bracket to Base	2	2
12	9915-118-002	Tube Assy, Drain	1	1
13	9545-030-002	Screw, Tube Mtg	2	2
14	9242-456-001	Hose, Tub to Drain Valve	1	1
15	9242-457-001	Hose, Drain Valve to Tube	1	1
16	8654-117-014	Clamp, Hose	4	4
*	9552-038-001	Shim, Support Assembly (thin)	AR	AR
*	9242-458-002	Hose, Vacuum Brkr. to Tub	1	1
23	9610-001-001	Vacuum Breaker	1	1
*	9029-077-001	Bracket, Vacuum Breaker	1	1
*	9545-008-005	Screw	4	4
20	9732-108-002	Dispenser,	1	1
21	9206-416-001	Gasket, Dispenser	1	1
*	9242-450-001	Hose, Dispenser to Tub	1	1
22	8654-117-008	Clamp, Dispenser Hose	2	2
17	9732-137-003	Back Ass'y, Tub	1	1
18	9991-056-002	Support Arm Ass'y, Bearing Housing	6	6
19	9545-059-002	Bolt, 7/16 x 2" Tub Back to Tub	12	12
19	8640-416-005	Nut, Flange Lock.....	12	12
*	9552-038-003	Shim (thick)	AR	AR

* Not Illustrated

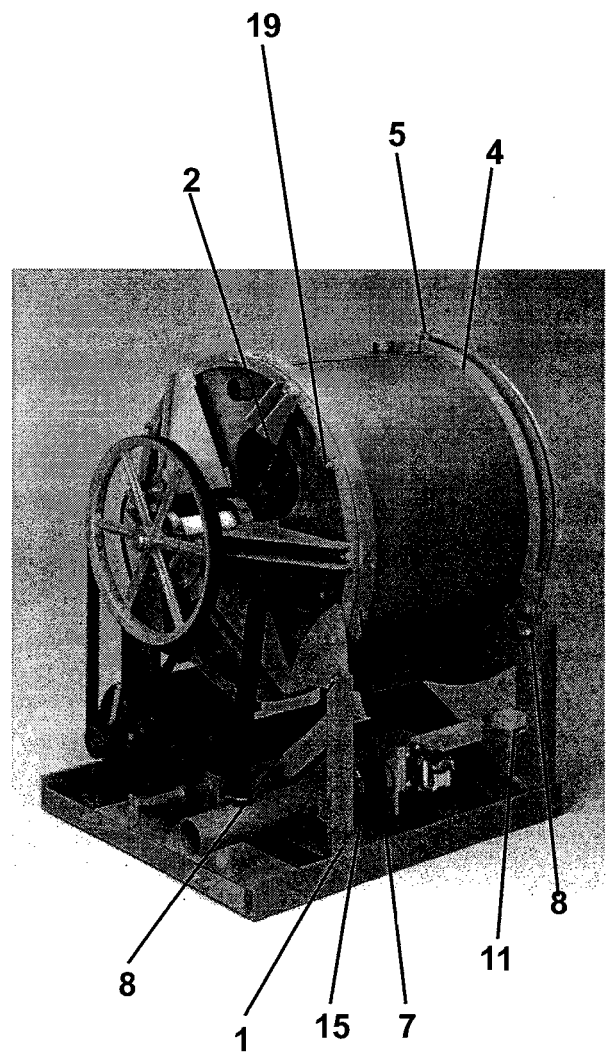
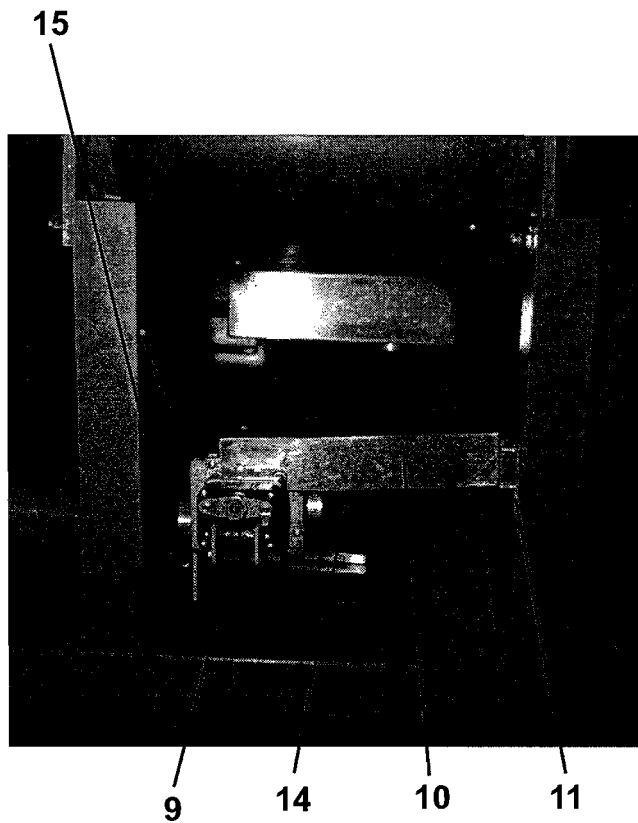
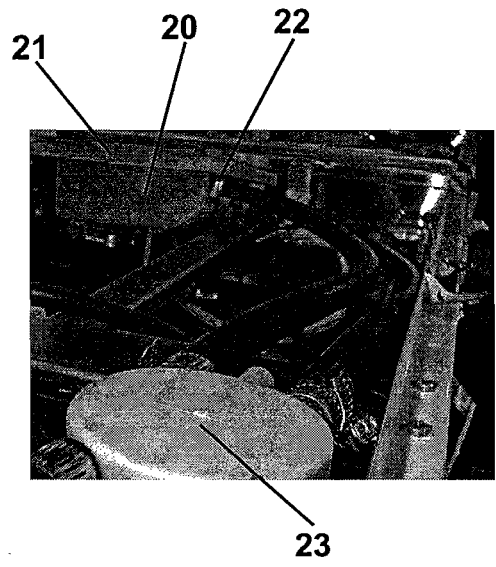
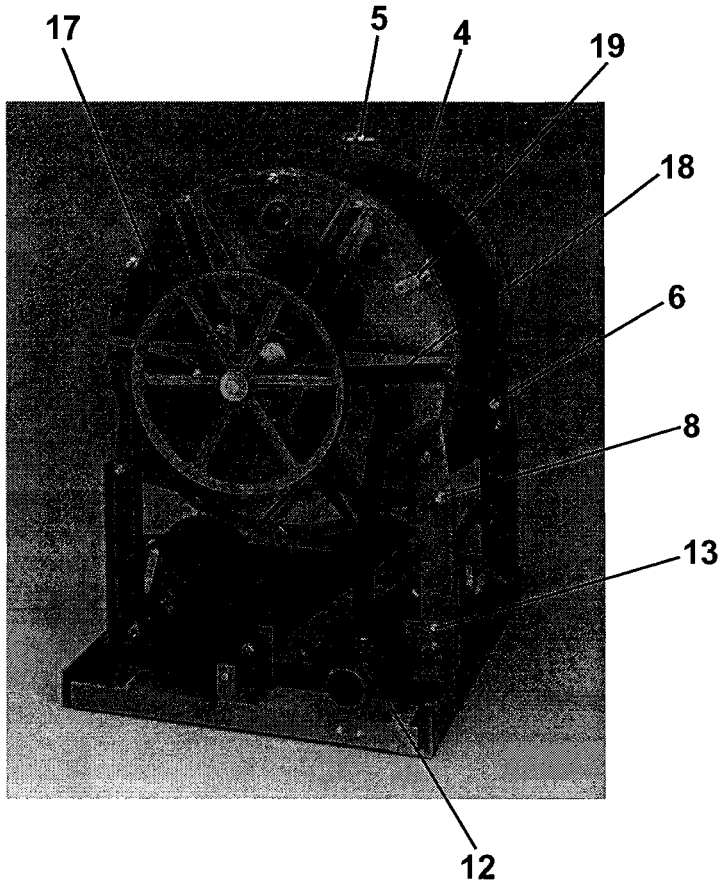

CYLINDER, WATER SEALS & BEARING HOUSING GROUP

Key	Part Number	Description	MODELS	
			WCN40	
			A	A
			A	B
1	9848-113-001	Cylinder, Assy	1	1
*	9803-186-001	Housing, Bearing- Assembly (includes items #2-#6)	1	1
2	9241-180-002	Housing, Bearing	1	1
3	9036-159-005	Bearing, Front(LARGE)	1	1
4	9036-159-004	Bearing, Rear (SMALL)	1	1
5	9538-167-001	Spacer, Bearing	1	1
6	9487-238-003	Ring, Bearing Retainer (Internal)	1	1
7	9732-137-003	Back Assy, Tub	1	1
8	9532-140-006	Seal, Secondary	1	1
9	9532-140-002	Seal, Primary	1	1
10	9950-048-001	Ring, Seal Mtg	1	1
11	9487-261-003	Seal Mating Ring (between bearing housing and tub back)	1	1
12	9545-060-001	Bolt, 5/8" x 1 1/2 Tub End of Bearing Housing	6	6
12	8640-425-001	Nut 5/8	6	6
12	8641-582-018	Lockwasher	6	6
13	9991-056-002	Support Arm Assy., Bearing Housing	6	6
14	9545-059-003	Bolt, 7/16" x 1 1/2 Pulley End of Brearing Housing	6	6
14	8640-416-005	Nut Flange Whz Lock 7/16	6	6
15	9453-168-003	Pulley, Driven	1	1
16	9487-234-003	Ring, Tolerance	1	1
17	8641-581-032	Washer 5/8 x 2 1/4 dia.	1	1
18	9545-060-001	Bolt 5/8 x 1 1/2	1	1
19	8641-582-018	Lockwasher	1	1
20	9545-059-002	Bolt 7/16 x 2 Tub Back and Supports	12	12

* Not Illustrated

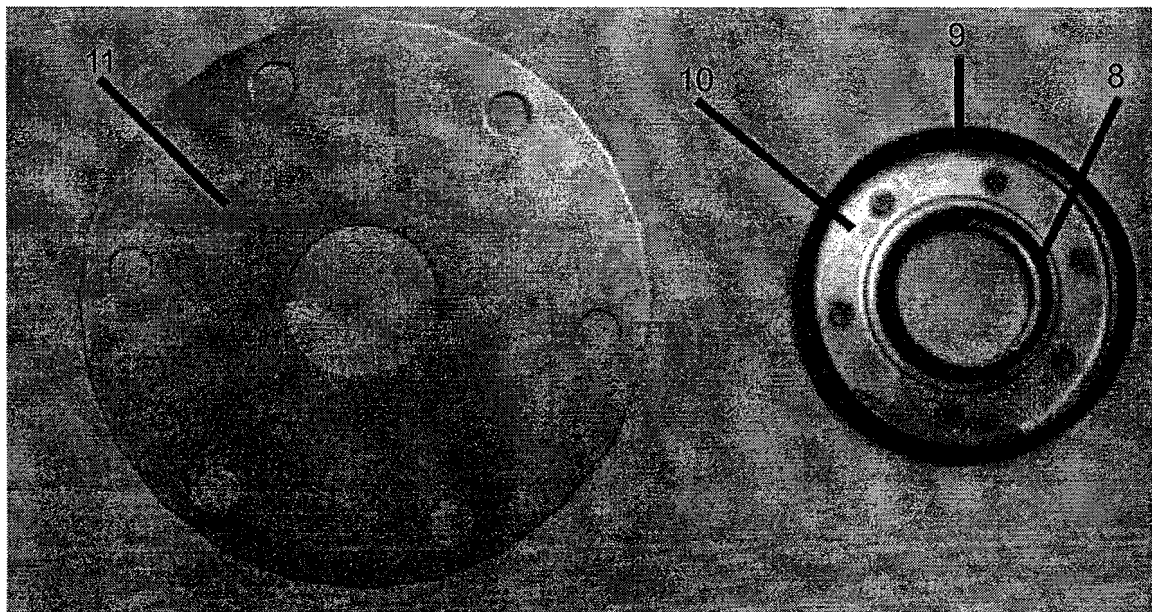

Cylinder Water Seals and Bearing Housing and Pulley Group

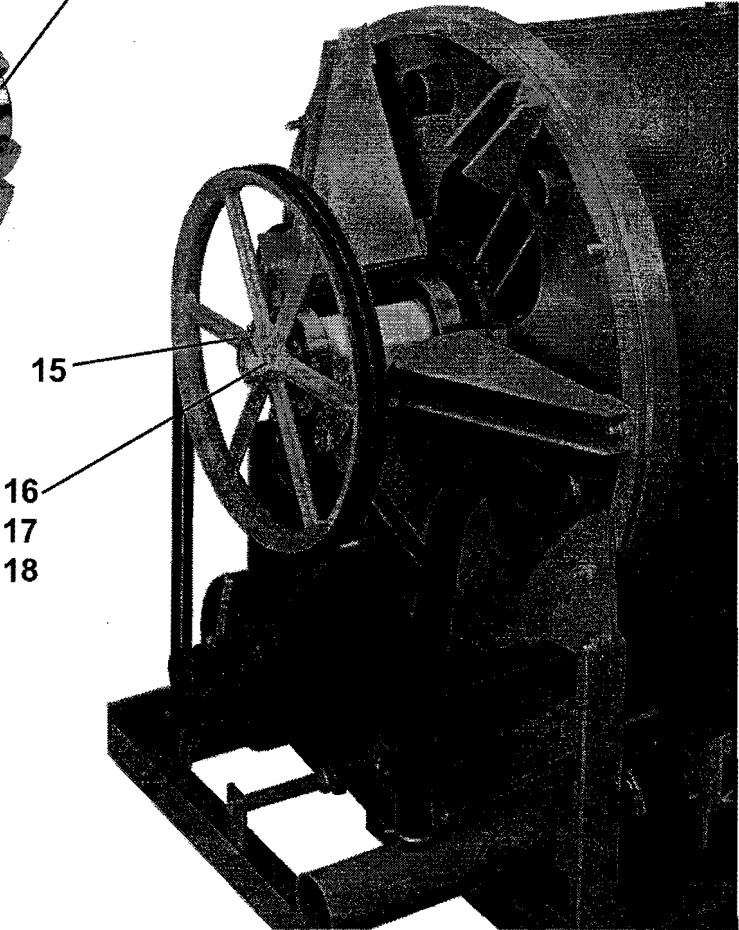
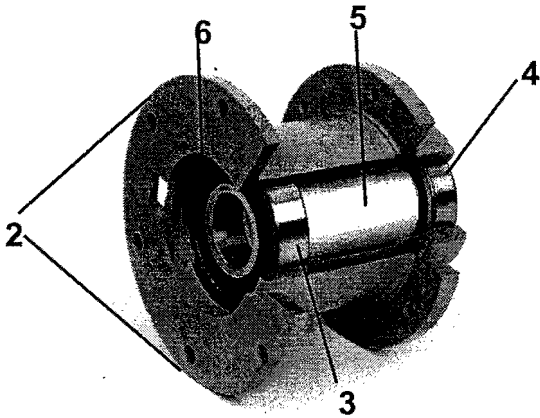
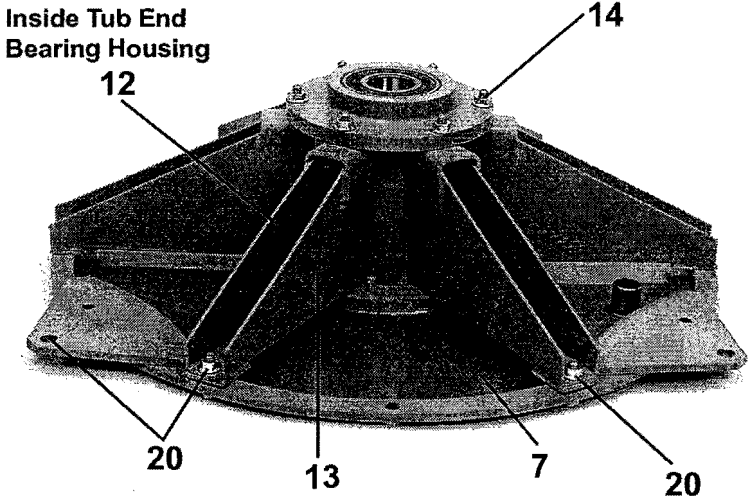

DOOR LOCK GROUP

Key	Part Number	Description	MODELS	
			WCN40	
			A	B
*	9885-023-001	Lock Assy, Complete (includes #1 thru #22).....	1	1
1	9982-284-001	Plate Assy, Door Lock	1	1
2	8641-581-030	Washer, Flat	1	1
3	9008-005-001	Actuator, Latching Switch	1	1
4	9450-002-002	Pawl, Locking	1	1
5	8641-569-003	Washer, Spring	1	1
6	9487-200-004	Ring, Retaining	1	1
7	9029-035-001	Bracket, Switch	1	1
8	8640-413-002	Nut, Hex	2	2
9	9534-364-002	Spring, Actuating	1	1
10	9545-012-020	Screw, Hx	1	1
11	8640-413-004	Nut, Elastic Stop	2	2
12	9534-364-001	Spring, Return	2	2
13	9451-193-001	Pin, Guide	1	1
14	9487-200-005	Ring, Retaining	1	1
15	8641-581-031	Washer	2	2
16	9539-461-008	Switch, Latching Sensing	1	1
17	9550-169-003	Shield, Switch	3	3
18	9545-020-001	Screw 4-40 x 5/8	2	2
18	8640-401-001	Nut, Twin	1	1
19	9539-461-007	Switch, Locking Sensing	2	2
20	9008-006-002	Actuator, Switch	2	2
21	9545-020-003	Screw 4-40 x 1 1/8	2	2
21	8640-401-001	Nut, Twin	1	1
22	9451-181-004	Pin, Dowel	1	1
*	9552-037-001	Shim, Door Lock, Thin	AR	AR
*	9552-037-002	Shim, Door Lock, Thick	AR	AR
*	9545-018-004	Screw, Lock mtg 1/4 -20 x 3/4	3	3
*	8641-582-007	Lockwasher 1/4 (ext. tooth)	3	3
*	9922-011-001	Solenoid Ass'y, Door Locking (includes 23 thru 32).....	1	1
23	9029-073-001	Door Locking Solenoid Bracket	1	1
24	9985-169-001	Bracket ass'y, Solenoid Slide	1	1
25	9536-074-001	Solenoid 120 volts 60 hz	1	1
26	9545-008-001	Screw, Solenoid Mtg	4	4
27	9540-033-002	Stop, Door Lock Solenoid	1	1
28	9545-061-001	Screw, Shoulder	1	1
28	8640-411-003	Nut, Keps #6	1	1
29	9586-001-001	Thermoactuator 120 V	2	2
30	9545-031-011	Screw #6 x 5/16	4	4
31	9538-157-004	Spacer, Plastic	1	1
31	9538-166-004	Spacer, Metal	1	1
31	9545-010-001	Screw, Cross Recessed	1	1
31	8640-412-005	Nut, Keps #8	1	1
32	8640-411-003	Nut, Keps #6	3	3
*	8640-413-002	Nut, Sol. Brkt to Control Panel	3	3
*	9497-225-003	Rod, Pull	1	1

* Not Illustrated

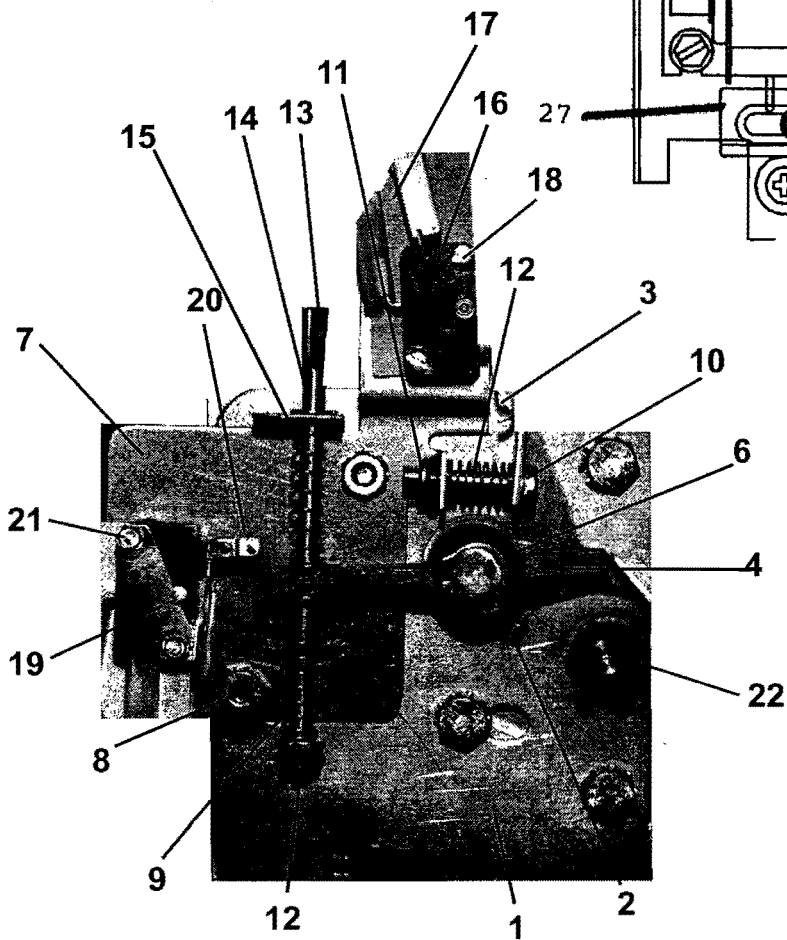
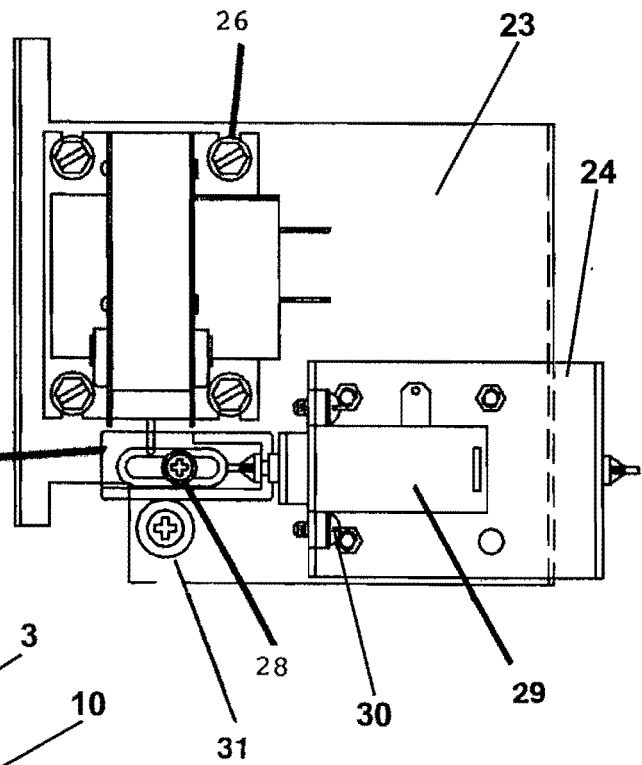
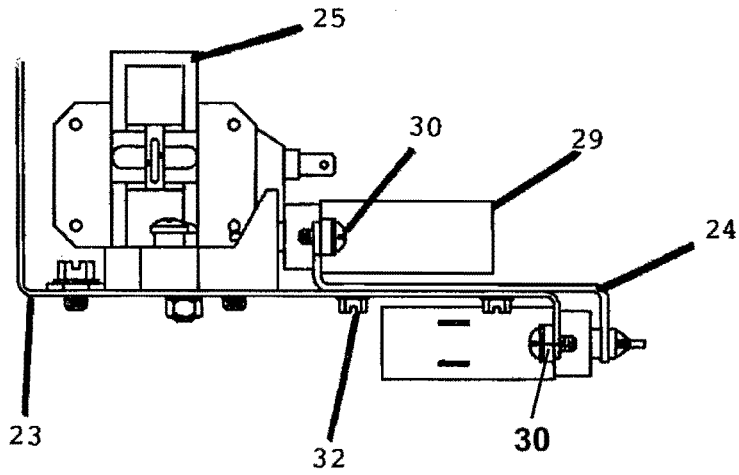

LOADING DOOR GROUP

Key	Part Number	Description	MODELS	
			WCN40	
			A	A
			A	B
*	9960-259-002	Loading Door, Complete (includes 1 thru 10)	1	1
1	9487-230-001	Loading Door, Ring	1	1
2	9206-419-001	Gasket, Loading Door	1	1
3	9635-016-001	Window, Loading Door	1	1
*	9913-134-003	Shaft Assy, Locking (includes 4 thru 7)	1	1
4	9537-195-002	Shaft, Door Locking	1	1
5	9095-040-001	Cam, Locking	1	1
6	9451-181-005	Pin, Groove (1 1/4).....	1	1
7	9451-181-004	Pin, Groove (3/4).....	1	1
8	9534-360-002	Spring, Lock Cam	1	1
9	9244-080-003	Handle, Door	1	1
*	9451-181-006	Pin, Door Handle (groove).....	1	1
*	9545-014-009	Screw, Hinge Mtg.....	3	3
*	8641-582-009	Lockwasher 5/16	3	3
*	9552-036-001	Shim, Loading Door Hinge, Thin	AR	AR
*	9552-036-002	Shim, Loading Door Hinge, Thick	AR	AR
10	9955-029-001	Hinge Assy, Loading Door (mounts to tub front)	1	1
11	9451-184-003	Pin, Loading Door Hinge (fits inside loading door hinge).....	1	1
15	8649-031-000	Ring, Snap Ring Ext.Retaining	1	1
12	9079-122-001	Clamp, Loading Door Hinge	1	1
13	9545-056-001	Screw, Loading Door Mtg	3	3
14	9487-254-001	Ring, Masking	1	1
*	8640-413-002	Nut	4	4
*	9059-063-002	Band, Edge Protector (mounted to front panel)	1	1

* Not Illustrated

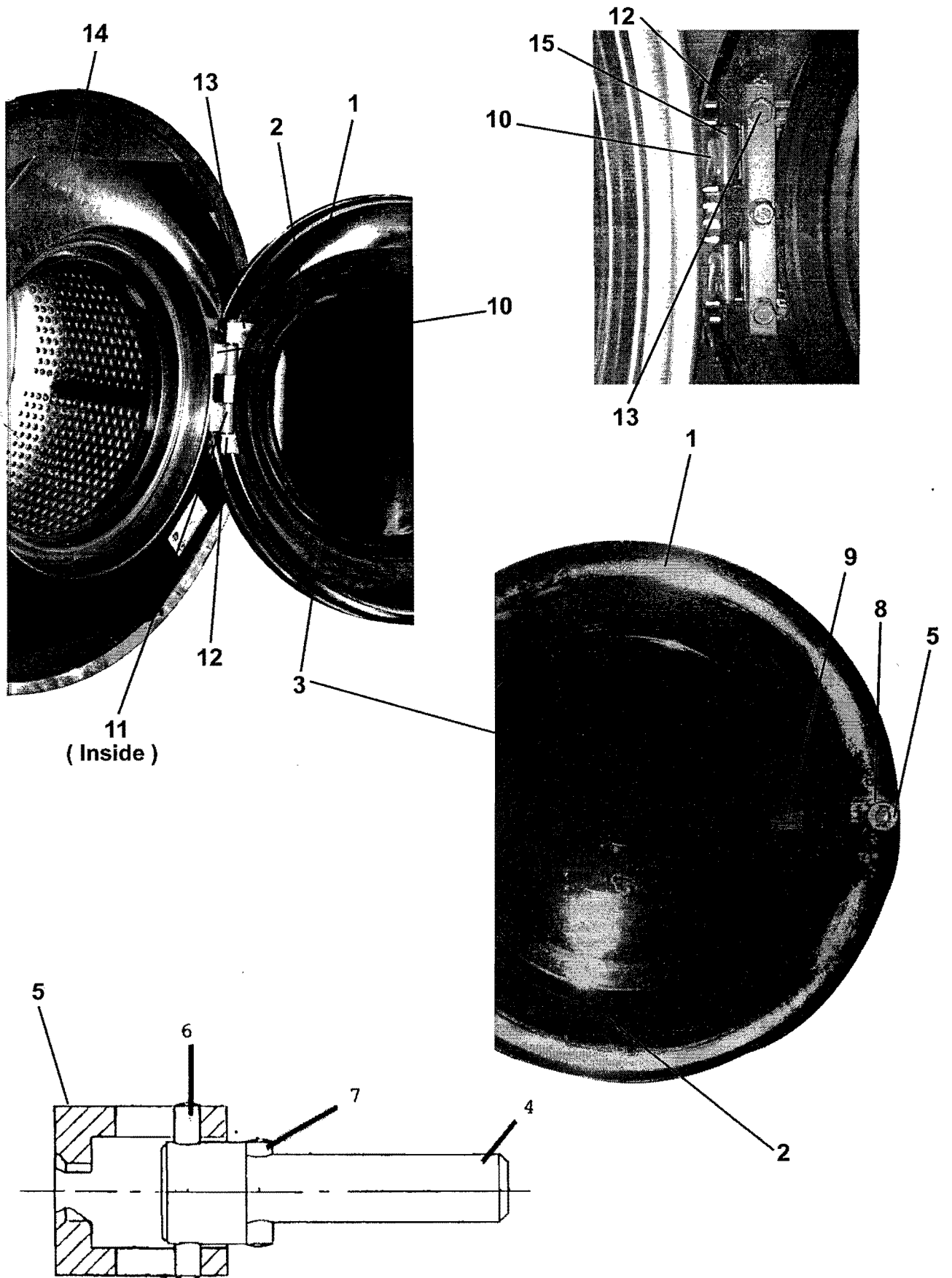

CONTROL PANEL GROUP

MODELS
WCN40

A A
A B

Key	Part Number	Description	A	B
1	9539-479-009	Switch, Push-button (cycle selector)	1	1
*	8640-412-005	Nut, Switch Mtg	2	2
2	3310-041-001	Light, Cycle Control	1	1
*	9206-100-001	Gasket, Light	2	2
3	3310-042-001	Light, Bleach	1	1
4	9020-005-001	Accumulator, Coin (with Time Remaining)	1	1
*	9627-682-001	Wiring Harness, Accumulator	1	1
*	9538-157-005	Short Spacer (between board and shields)	3	3
5	9550-174-001	Shield, Circuit Board with Timer Remaining	1	1
*	8640-412-005	Nut, Hx	3	3
*	9538-157-003	Long Spacer (between board and panel)	3	3
6	9021-001-010	Acceptor, Coin (See Coin Handling Group).....	1	1
7	9732-122-001	Kit, Coin Box W/Hardware	1	1
8	9412-076-006	Nameplate, Control Panel (one piece, w / time remaining)	1	1
9	Solenoid Ass'y, Door Locking (see Door Lock Group for parts breakdown).....	1	1	
*	8640-412-005	Nut Hx (mounting solenoid assy. to countdown).....	3	3

* Not Illustrated

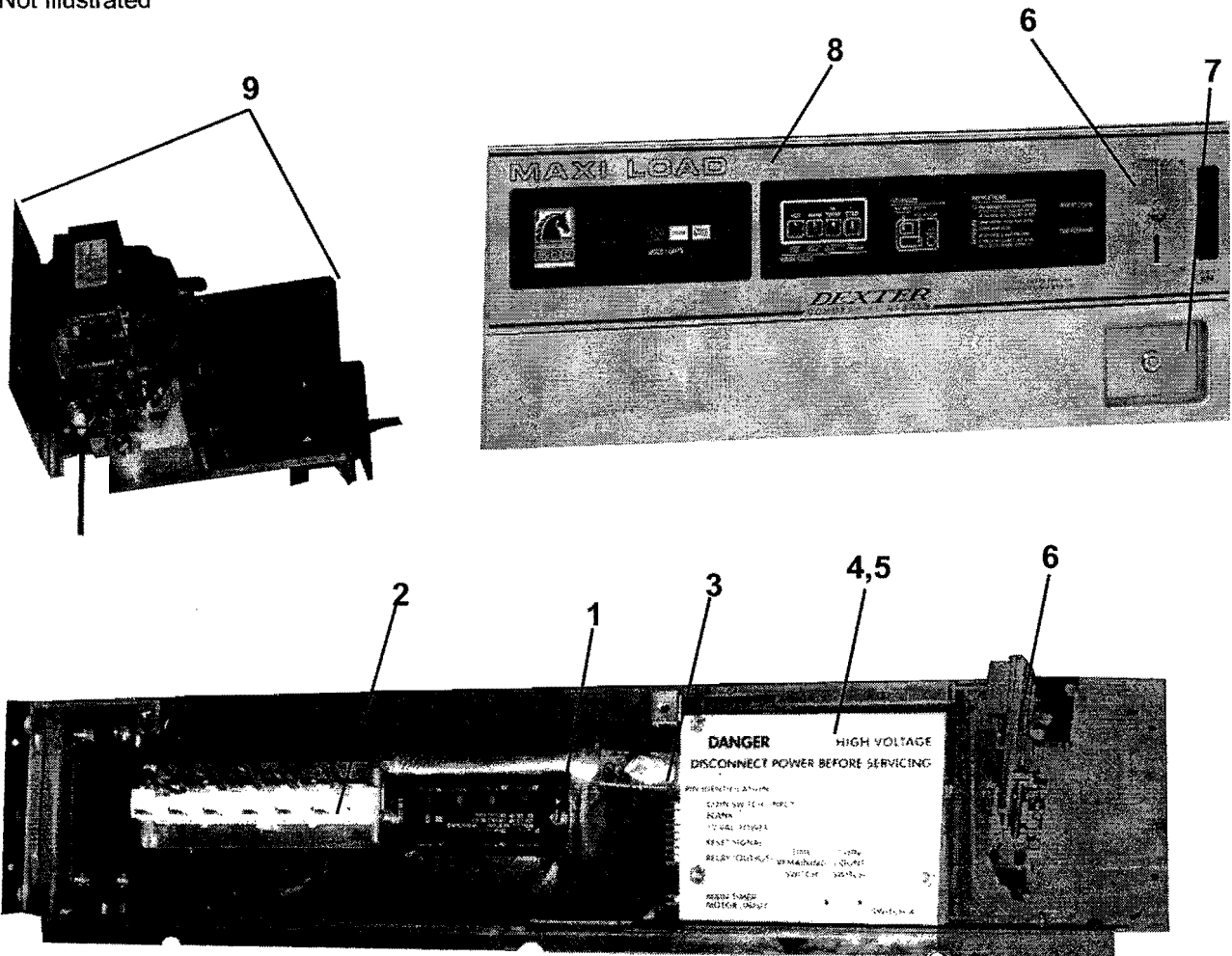

WATER INLET GROUP

Key	Part Number	Description	MODELS	
			WCN40	
			A	A
			A	B
1	9379-183-003	Valve, Water Inlet	2	2
		(see Water Inlet Valve Breakdown for individual parts)		
*	9545-008-026	Screw, Valve Mtg	4	4
*	8640-399-006	Nut, Spring	4	4
2	9610-001-001	Vacuum Breaker	1	1
*	9029-077-001	Bracket, Vacuum Breaker	1	1
3	9545-008-026	Screw	4	4
4	9242-458-002	Hose, Vacuum Breaker to Tub-Ribbed	1	1
*	8654-117-014	Clamp, Vac. Brkr. End	1	1
*	8654-117-009	Clamp, Tub End	1	1
5	9242-453-008	Hose, Vacuum Breaker to Wash Dispenser 26	1	1
6	9242-453-009	Hose, Vacuum Breaker to Rinse Dispenser 23	1	1
7	9242-453-020	Hose, Hot Valve to Vacuum Breaker 18	1	1
8	9242-453-020	Hose, Hot Valve to Tub 18	1	1
9	9242-453-020	Hose, Cold Valve to Vacuum Breaker 18	1	1
10	9242-453-020	Hose, Cold Valve to Tub 18	1	1
*	8654-029-000	Clamp, Hose-Spring (overflow from drain to tub back)	2	2
*	8654-117-015	Clamp, Hose-Worm	10	10
11	5198-211-004	Circuit Breaker	1	1

* Not Illustrated

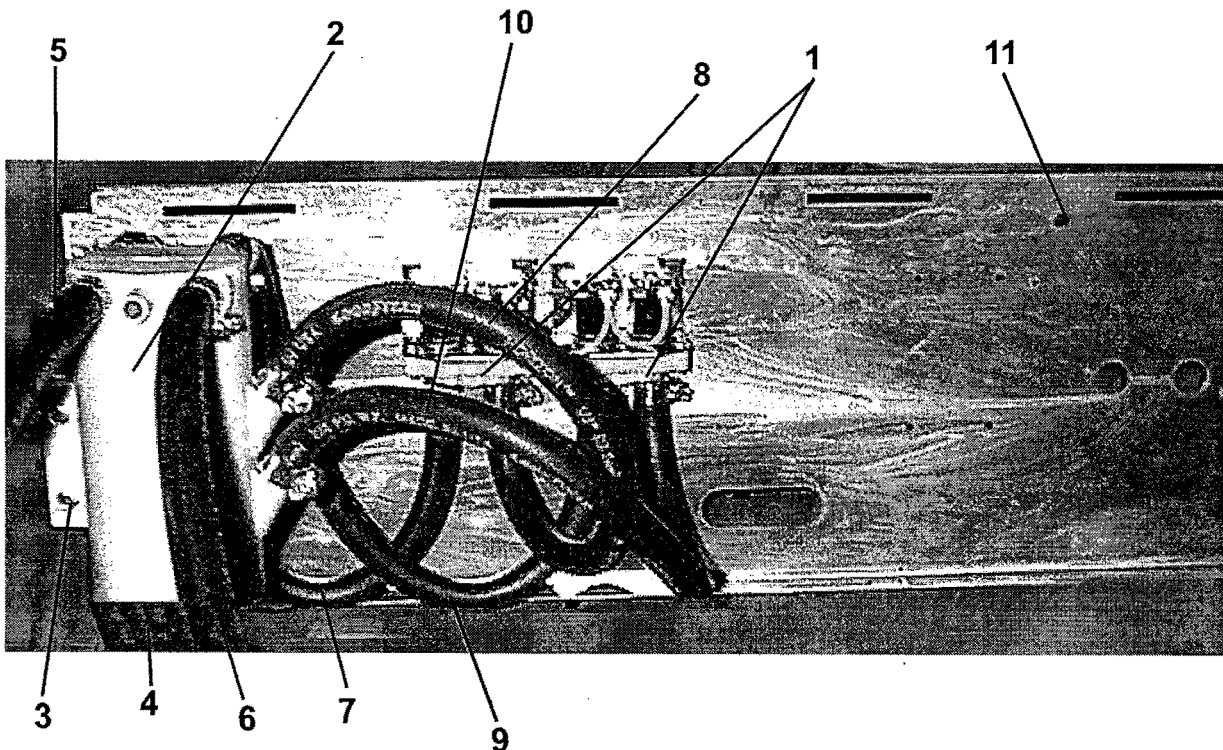

ELECTRICAL COMPONENTS - TOP COMPARTMENT

SINGLE PHASE ONLY

Key	Part Number	Description	MODELS	
			WCN40	
			A	A B
1	9839-012-003	Trough Assy, Controls Mtg	1	
2	9003-229-001	Angle, Trough to Rear Channel	1	
*	9545-008-026	Screw	4	
3	5191-102-006	Capacitor, Spin-Start	1	
4	5191-103-009	Capacitor, Run-Tumble	1	
5	9544-054-001	Strap, Capacitor Mtg	1	
*	9545-045-001	Screw, Capacitor Strap	2	
6	5192-286-007	Relay, Tumble	2	
7	5192-286-008	Relay, Spin	1	
8	9571-362-001	Timer, Program	1	
		(VERIFY PART NUMBER ON TIMER BODY)		
*	9376-295-002	Motor, Timer Main Drive	1	
9	9376-286-004	Motor, Timer Rapid Advance	1	
*	9545-012-001	Screw, Timer Mtg	2	
10	9107-068-001	Dial, Timer Label	1	
11	9307-176-001	Knob, Timer (w/set screws)	1	
12	9571-360-001	Timer, Reversing	1	
*	9545-044-004	Screw, Reversing Timer	2	
13	9897-035-001	Terminal Block, Power Connection	1	
*	9545-045-007	Screw, Mtg	2	
*	8502-619-003	Label, Fusing and Installation	1	
14	9897-029-001	Terminal Block Assy, 12 Lug	1	
*	9545-045-007	Screw, Mtg	2	
*	9558-022-001	Strip, Terminal Marker	1	
15	9539-457-001	Switch, Pressure	1	
*	9545-045-001	Screw, Mtg	2	
16	5198-211-004	Circuit Breaker, 1.5 amp	1	
17	8652-130-037	Lug, Grounding Terminal	1	
*	8639-621-007	Screw, Mtg	1	
*	8641-582-006	Lockwasher	1	
18	9539-478-002	Solid State Start Switch	1	
*	9029-062-001	Strap, Mtg	1	
*	9545-010-001	Screw	1	
*	8640-412-005	Nut	1	
*	9545-031-003	Screw, Mtg Strap to Control Trough	3	
19	8711-003-001	Transformer, (For Accumulator) 120V/12V	1	
*	9545-045-001	Screw, Mtg	2	
*	8641-582-005	Lockwasher	2	

* Not Illustrated

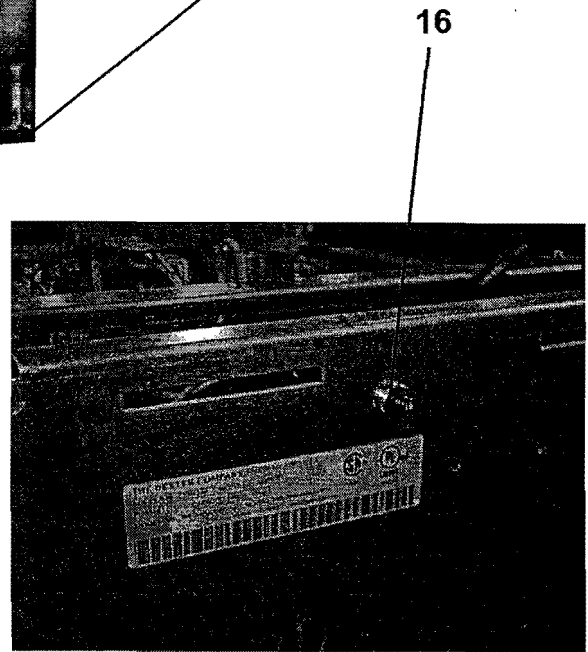
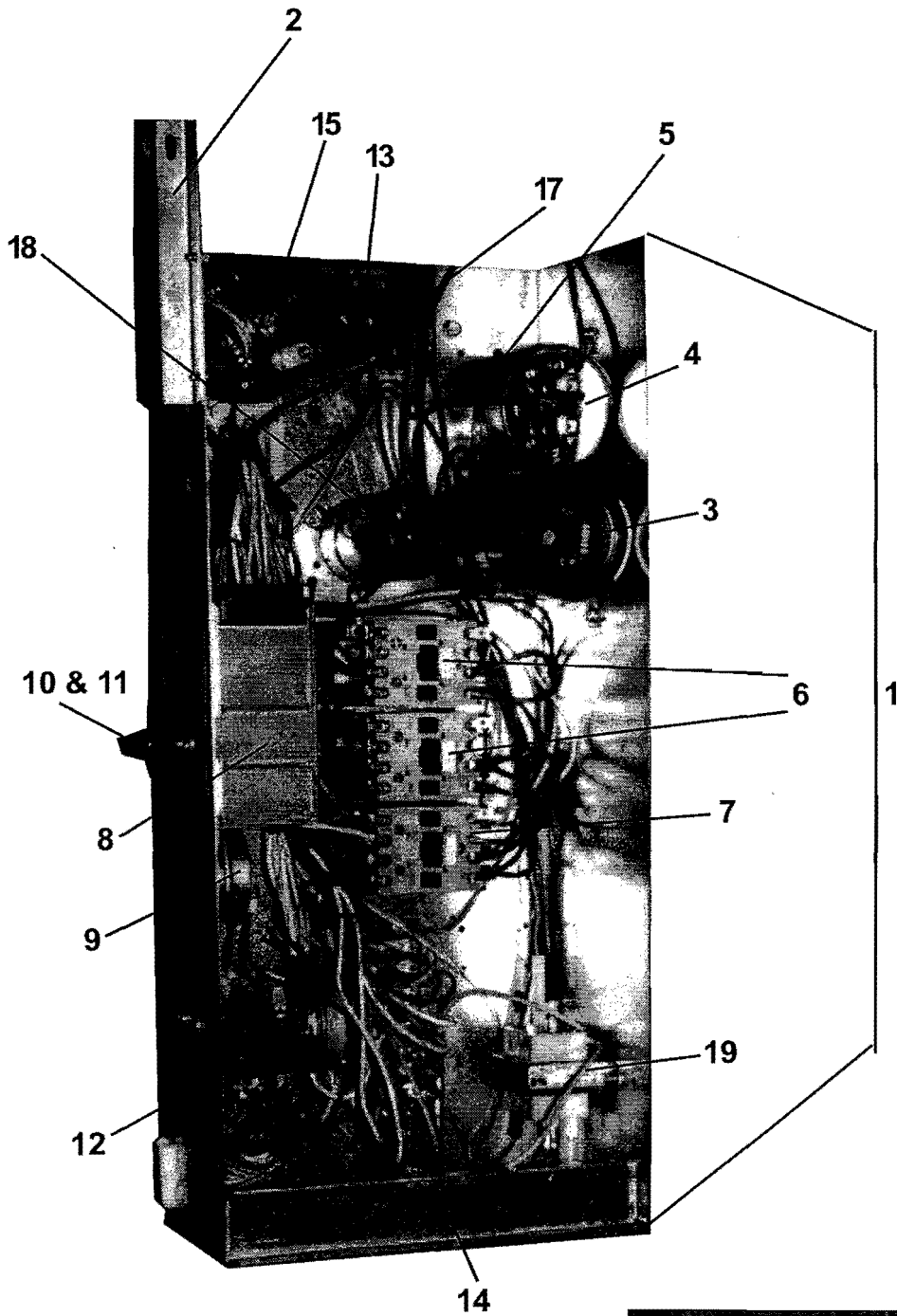

ELECTRICAL COMPONENTS - TOP COMPARTMENT

THREE PHASE ONLY

MODELS
WCN40

A A
A B

Key	Part Number	Description	A	B
1	9839-012-003	Trough Assy, Controls Mtg		1
*	9003-229-001	Angle, Trough to Rear Channel		1
*	9545-008-026	Screw		4
3	5192-286-007	Relay, Tumble		2
4	5192-286-009	Relay, Spin		1
5	8711-004-001	Transformer, Control		1
*	8507-230-001	Transformer Instructions		1
*	9545-008-005	Screw		1
*	8641-582-006	Lockwasher		1
6	9571-362-001	Timer, Program		1
	(VERIFY PART NUMBER ON TIMER BODY)			
*	9376-295-002	Motor, Timer Main Drive		1
7	9376-286-004	Motor, Timer Rapid Advance		1
*	9545-012-001	Screw, Timer Mtg		2
8	9107-068-001	Dial, Timer Label		1
9	9307-176-001	Knob, Timer (w/set screws)		1
10	9571-360-001	Timer, Reversing		1
*	9545-044-004	Screw, Reversing Timer Mtg		2
11	9897-035-002	Terminal Block, Power Connection		1
*	9545-045-007	Screw, Mtg		2
*	8502-619-004	Label, Fusing		1
12	9897-029-001	Terminal Block Assy, 12 Lug		1
*	9545-045-007	Screw, Mtg		2
*	9558-022-001	Strip, Terminal Marker		1
13	9539-457-001	Switch, Pressure		1
*	9545-045-001	Screw, Mtg		2
14	5198-211-004	Circuit Breaker, 1.5 amp		1
15	8652-130-037	Lug, Grounding Terminal		1
*	8639-621-007	Screw, Mtg		1
*	8641-582-006	Lockwasher		1
16	8711-003-001	Transformer, (For Accumulator) 120V / 12 V		1
*	9545-045-001	Screw, Mtg		2
*	8641-582-005	Lockwasher		2

* Not Illustrated

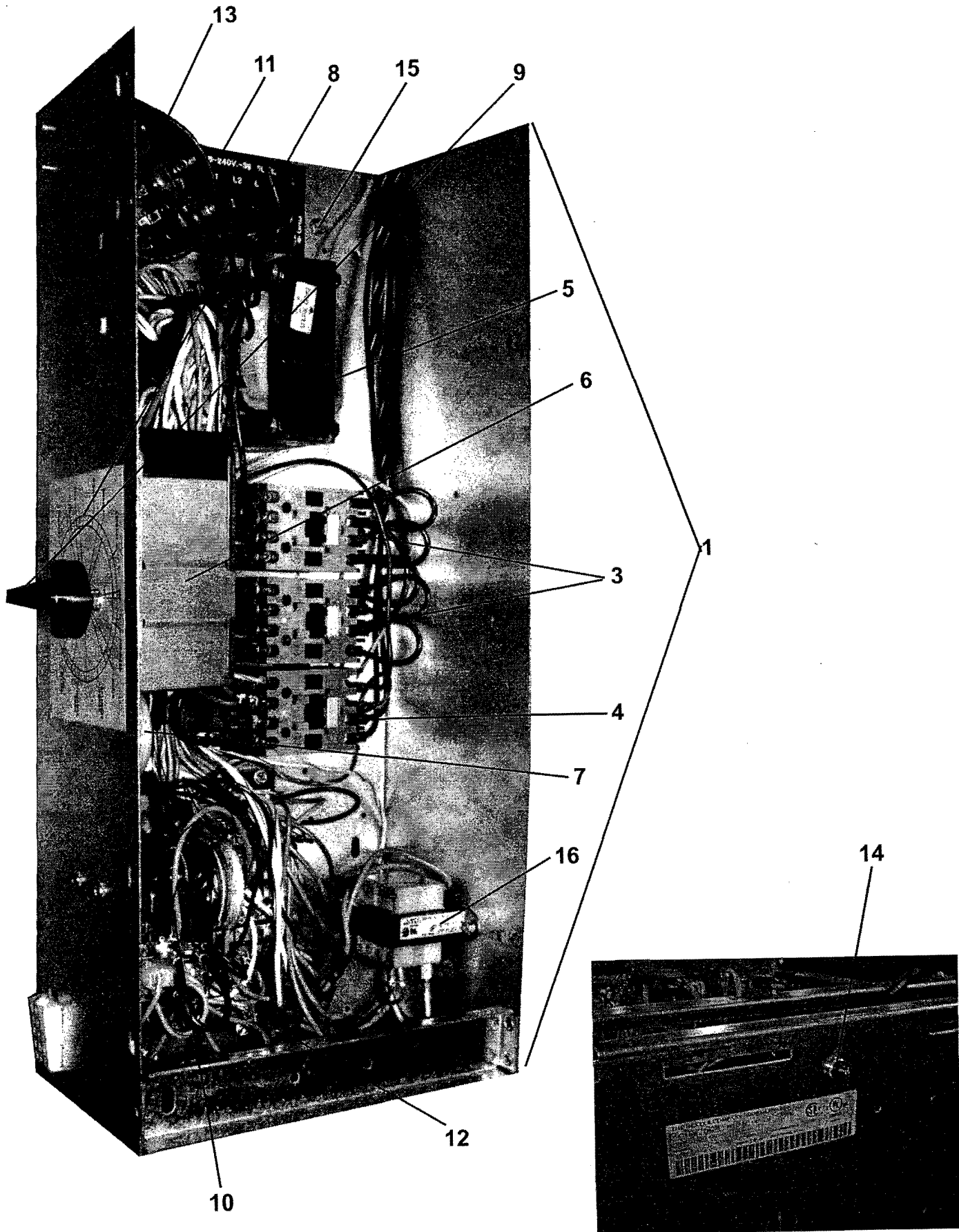

COIN HANDLING GROUP

MODELS
WCN40

A A
A B

Key	Part Number	Description		
1	9942-026-006	Vault, Assy	1	1
*	9545-008-026	Screw, Vault Mtg	4	4
 NOTE: COIN BOX AND HARDWARE KIT AND COIN BOX LOCK NOT INCLUDED WITH MACHINE.				
2	9732-122-001	Kit, Coin Box W/Hardware (includes 3 thru 6)	1	1
3	9349-033-001	Latch, Coin Box	1	1
4	8641-569-002	Washer, Wave	1	1
5	8641-583-001	Washer, Keeper	1	1
6	8641-581-008	Washer, Spacer- Thick	2	2
6	8641-581-010	Washer, Spacer- Thin	4	4
7	8650-012-003	Lock, Coin Box (w/key not included with 9732-122-001)	1	1
8	9940-014-004	Chute Assy., Coin	1	1
*	9545-008-001	Screw, Chute Mtg	1	1
11	9119-025-002	Coin Acceptor chute without penny rejector (standard)	1	1
9	9021-001-010	Acceptor, Coin	1	1
*	9545-020-002	Screw, Acceptor Mtg	4	4
*	8640-424-002	Nut	4	4
10	9732-126-001	Switch, Coin	1	1
12	9119-025-001	Coin Acceptor chute with penny rejector (optional)	optional	
13	9486-133-001	Button Coin Return Retainer	1	1

* Not Illustrated

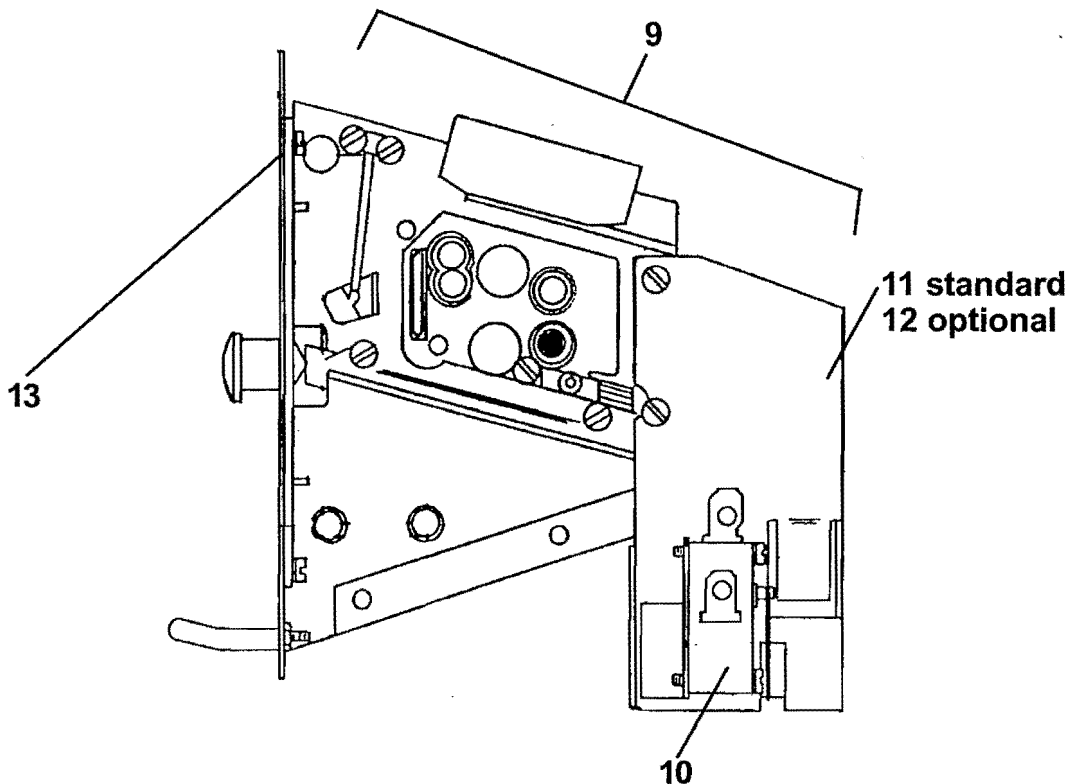

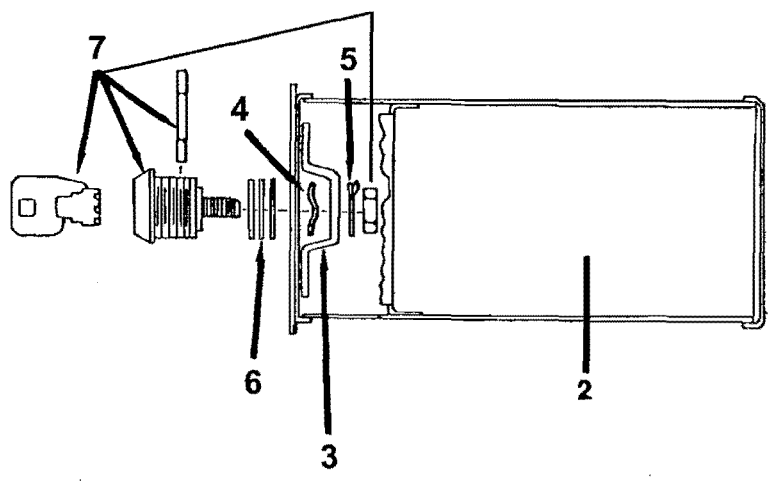
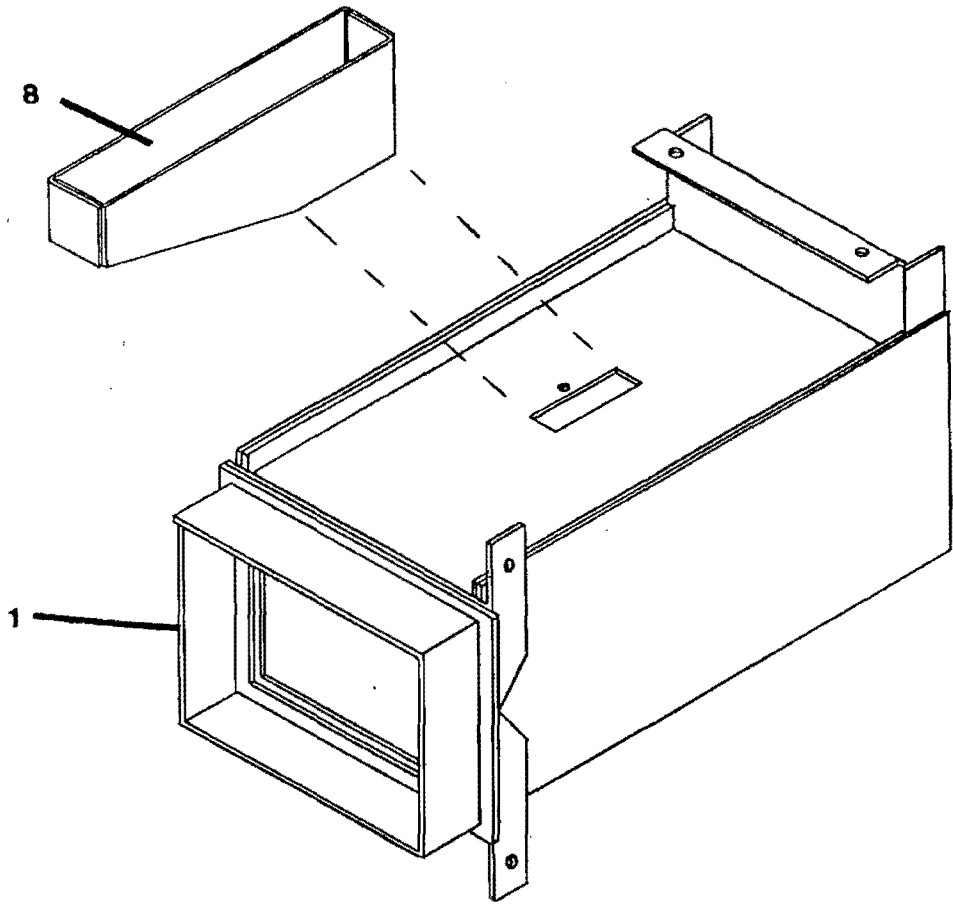

WATER INLET VALVE BREAKDOWN

**MODELS
WCN40**

A	A
A	B

Key	Part Number	Description	A	B
*	9379-183-003	Valve, Water Inlet Blue (includes 1 thru 6)	2	2
1	9555-056-001	Screen, Inlet end of valve	2	2
2	9089-017-001	Coil Assy., 120 V	2	2
3	9118-049-001	Diaphragm	2	2
4	9211-021-002	Guide, Solenoid	2	2
5	9015-008-001	Armature	2	2
6	9534-298-001	Spring, Armature	2	2
*	9545-008-026	Screw, Valve Mtg	2	2

* Not Illustrated

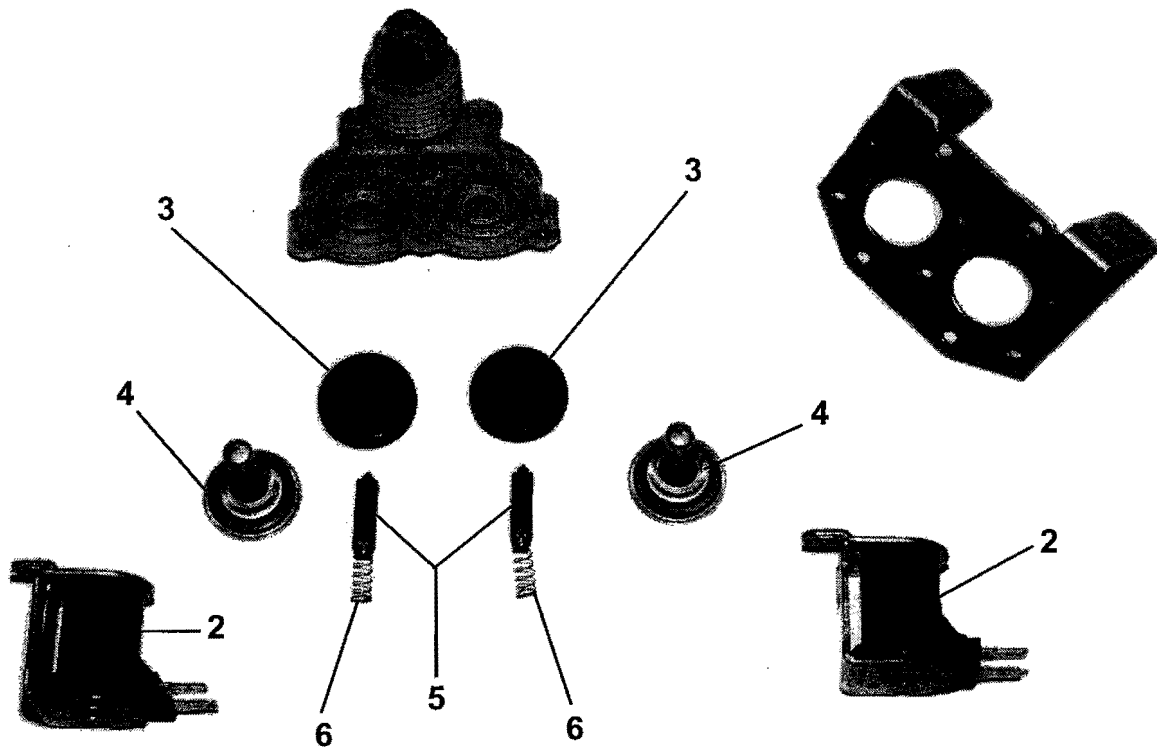

DRAIN VALVE GROUP

MODELS
WCN40
A A
A B

Key	Part Number	Description		
*	9379-187-001	Valve, Drain (includes 2 thru 11)	3	1 1
2	9064-070-001	Body, Valve (w/ball)		1 1
3	9914-137-001	Motor & Gear Train		1 1
4	9452-538-001	Plate, Motor Mtg		1 1
5	8639-994-001	Screw		3 3
6	9534-339-001	Spring, Drive		1 1
7	9545-054-001	Screw		2 2
8	9545-054-002	Screw		1 1
9	9532-134-001	Seal, V Packer		2 2
10	8641-584-001	Washer		1 1
11	9451-196-001	Pin, Main Drive		1 1
12	9538-149-001	Plate (spacers needed for replacement motor mtg. plate)		4 4

* Not Illustrated

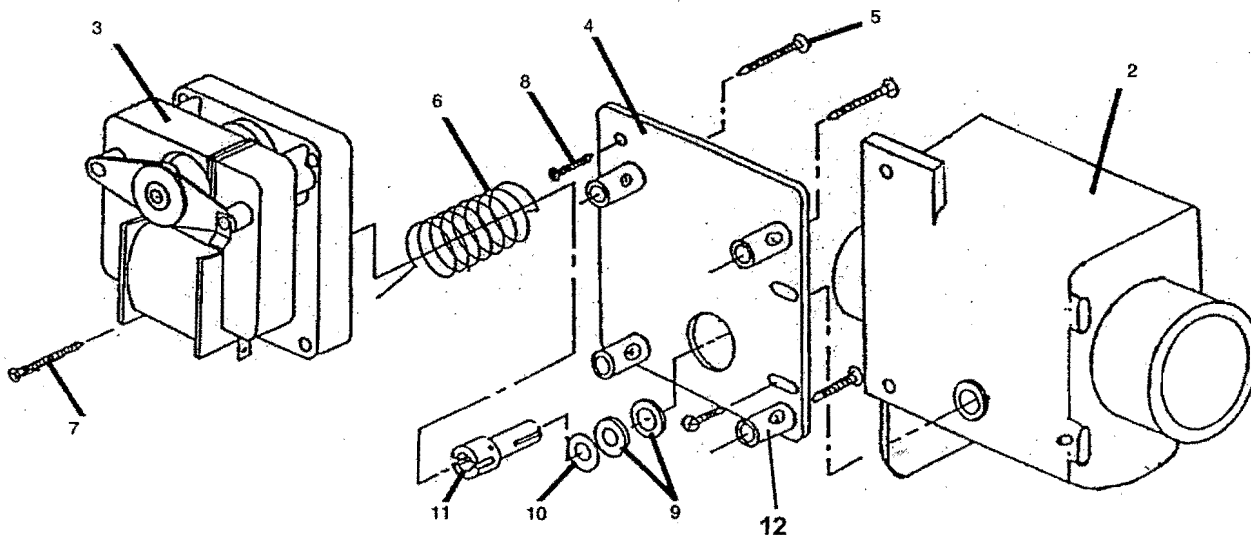

Valve
Complete

WIRING HARNESS GROUP

			MODELS	
			WCN40	
			A	A
Key	Part Number	Description	A	B
USE FOLLOWING ITEMS WITH TIMER PART NUMBER 9571-359-002				
	9627-680-002	Wiring Harness, Main	1	1
	9627-681-003	Wiring Harness, Control.....	1	1
	9627-682-001	Wiring Harness, Coin Accumulator	1	1
	9627-683-001	Wiring Harness, Drain Valve	1	1
	8654-125-001	Clamp, Cable- 1/4" Diameter	1	1
	8653-074-001	Connector, Clear In-Line	AR	AR
USE FOLLOWING ITEMS WITH TIMER PART NUMBER 9571-362-001				
	9627-708-001	Wiring Harness , Countdown	1	1
	9627-682-001	Wiring Harness , Coin Accumulator	1	1
	9627-695-001	Wiring Harness , Main	1	1
	9627-689-001	Wiring Harness , Control	1	1
	9627-683-001	Wiring Harness , Drain Valve	1	1

LABELS AND DIAGRAMS

8502-614-004	Label , High Voltage
8502-619-003	Label , Fusing and Instructions
8502-620-001	Label , Motor Connections
8502-624-002	Label , Door Opening
8507-274-001	Spin Direction
8511-001-002	Label , Quality
8514-021-002	Owners Booklet
9345-787-002	Wiring Schematic (1 ph / 3 ph)
9345-788-004	Wiring Diagram (1 ph)
9345-789-004	Wiring Diagram (3 ph)

Section 8

Maintenance

Daily

1. Clean the top and the cabinet to remove residue.
2. Clean the soap dispenser and soap lid.
3. Check the drain for leaking and proper draining.
4. Check the loading door for leaks.
5. Clean the door seal of all foreign material.
6. Leave the loading door open to aerate the washer when not in use.

Quarterly

Make sure the power is disconnected before making the following checks.

1. Check the drive belt for wear and proper tension.
2. Clean lint and other foreign material from around drive motor.
3. Check all water connections for leaks.
4. Wipe and clean the inside of the washer and check all electrical components for moisture and dust.
5. Remove and clean water inlet hose filters. Replace if necessary.
6. After any service always replace all panels before reconnecting electrical power.

