

Section 6

Parts Data

Thoroughbred 400

Accessories

Models	WCN25AA	220-240	volts	60hz.	Single Phase
	WCN25AB	208-240	volts	60hz.	Three Phase

MODELS	
WCN25	
A	A
A	B

Part Number	Description		
9732-139-002	Kit, Door Gasket Expander (large)		
9732-139-001	Kit, Door Gasket Expander (small)		
Grip-O-Matic #1038	Puller to Remove Pulley and Bearing Housing from Shaft on T-400		
9990-027-011	Hose, Water Supply (furnished) 3/8" I.D. x 48"	2	2
9990-027-013	Hose, Water Supply (optional) 5/8" I.D. x 48"		
8641-242-000	Washer, Inlet Hose (furnished)	2	2
9565-003-001	Strainer, Inlet Hose (furnished)	2	2
9242-417-001	Drain hose 10 ft. length x 2-1/4" I.D.		
9242-417-003	Drain hose 10ft. length x 3" I.D.		
8641-586-002	Bevel Washer for 5/8" bolt used in installations using angle iron bases		
8641-586-003	Bevel Washer for 3/4" bolt used in installations using angle iron bases		
9732-139-001	Kit, Door Gasket Expander (large)		
9732-139-002	Kit, Door Gasket Expander (small)		
9732-140-001	Manual Operation Kit		
9539-474-001	Switch, Blk/Red (included in kit)		
9539-474-002	Switch, Blk/Wht (included in kit)		
8545-055-002	Electrical Probe 100-600VAC		
8545-055-001	Electrical Probe 24-90 VAC		
8538-151-001	Sealing compound		
8545-051-002	TORX#20		
8545-051-003	Special Tool For Removing Coin Acceptor Mounting Screws. (T-10 Torx)		
9475-002-002	Flow Restrictors (in dispenser)		

CABINET AND FRONT PANEL GROUP

Key	Part Number	Description	MODELS	
			WCN25	
			A	A
			A	B
1	9454-656-001	Panel, Side (Left or Right) - Stainless	2	2
2	9545-018-013	Screw, (Side Panel to Base)	6	6
2	8640-414-006	Nut, Hex	6	6
*	9029-066-001	Bracket, Side Panel	1	1
*	8640-413-002	Nut, Hex	2	2
*	9545-008-005	Screw	2	2
3	9454-659-001	Panel Assy, Front	1	1
4	9059-063-002	Band, Edge Protector	1	1
*	9545-008-024	Screw, Hex- To Control Panel	2	2
*	8640-399-005	Nut, Spring- To Control Panel	2	2
5	9545-008-014	Screw, Flat Head- Front to Sides	2	2
5	8641-585-001	Washer, Finish	2	2
*	8640-399-008	Nut, Spring- To Front Panel	2	2
*	9545-008-023	Screw, Guide	2	2
6	8502-624-002	Label, Door Opening	1	1
7	9989-452-001	Panel, Control (Mounts Nameplate)	1	1
*	9545-008-006	Screw, Control Panel to Sides	4	4
8	9412-076-007	Nameplate, Control Panel (one piece)	1	1
9	9454-663-001	Panel, Top	1	1
10	8650-012-003	Lock, Top (w/Key)	1	1
*	9306-025-001	Key, Top-6324	1	1
*	9095-038-001	Cam, Lock-Top	1	1
*	8640-426-001	Nut, 9/32	1	1
*	8641-581-008	Washer	1	1
11	9108-097-001	Door, Lower Service	1	1
12	9244-081-002	Handle (bumper guard)	1	1
*	9545-045-010	Screw	4	4
*	9545-008-023	Screw, Guide	2	2
13	9545-008-014	Screw Mtg., Flat Head	2	2
13	8641-585-001	Washer, Finish	2	2
*	8640-399-008	Nut, Spring	2	2
14	9108-095-003	Door, Dispenser	1	1
*	9451-191-001	Pin, Plain	2	2
*	9467-025-001	Post, Door Mounting	2	2
*	9545-045-002	Screw, Dispenser Post Mtg	4	4
*	9545-008-012	Screw, Dispenser Mounting	4	4
*	8640-399-007	Nuts, Spring	4	4
*	9086-017-001	Catch, Top Panel	1	1
*	9467-024-001	Post, Top Locator	2	2
*	8640-411-003	Nut, Keps	2	2
*	9355-001-001	Locator, Panel	2	2
*	9545-008-025	Screw, #10	2	2
15	9732-122-001	Box Assy, Coin (See Coin Handling Group)	1	1
16	9021-001-010	Acceptor, Coin (See Coin Handling Group)	1	1

* Not Illustrated

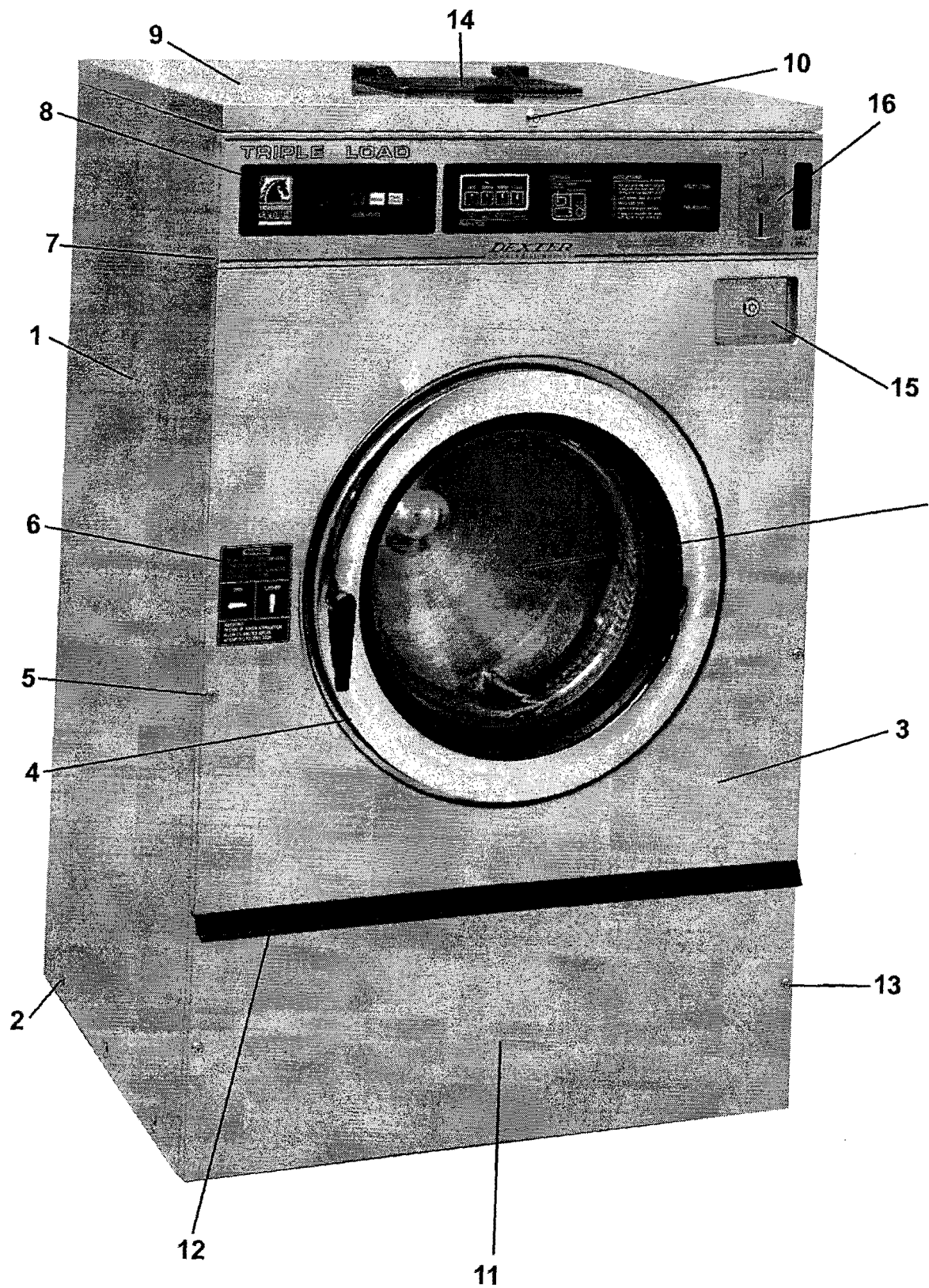

REAR VIEW

Key	Part Number	Description	MODELS	
			WCN25	
			A	A
			A	B
1	9732-127-001	Drive Motor, 1 Phase	1	
1	9732-127-002	Drive Motor, 3 Phase		1
2	9497-222-002	Rod, Motor Mtg	1	1
*	9545-029-005	Screw (end of motor rod)	1	1
*	8641-582-014	Lockwasher (end of motor rod)	1	1
3	9076-052-002	Collar, Shaft (w/set screws)	3	3
4	9453-170-002	Pulley, Motor (after serial number #425720)	1	1
*	9487-234-001	Tolerance Ring	1	1
*	9545-028-015	Set Screw, Sq. Hd.	2	2
5	9453-168-002	Pulley, Driven old style single belt before # 425720)		
5	9453-168-004	Pulley, Driven (after serial nnnnnumber #425720)	1	1
6	9545-017-009	Screw	1	1
7	8641-581-026	Washer, Flat	1	1
6	8641-582-016	Lockwasher	1	1
8	9040-076-005	Drive Belt (2 required after serial number # 425720)	2	2
9	9081-104-001	Channel, Rear	1	1
10	9545-008-026	Screw	4	4
*	8640-399-004	Nut, Spring	4	4
11	9242-449-002	Hose, Overflow	1	1
12	8654-029-000	Clamp, Hose	2	2
*	9989-446-002	Panel Assy., Back	1	1
*	9545-008-026	Screw	10	10
*	8640-399-004	Nut, Spring	10	10
13	9545-030-002	Screw, to Base	2	2
14	9242-175-000	Hose, Pressure Switch	1	1
*	8654-117-015	Clamp, Pressure Sw. Hose	1	1
15	5198-211-004	Circuit Breaker, 1.5 amp	1	1
16	9242-458-002	Hose, Vacuum Breaker to Tub	1	1
*	8654-117-014	Clamp, Hose to Vacuum Breaker	1	1
*	8654-117-009	Clamp, Hose to Tub	1	1
17	9029-027-003	Strap Bracket, Motor Tension	1	1
18	8640-413-002	Nut, Strap to Motor	1	1
18	8641-581-006	Washer	1	1
19	9534-319-002	Spring, Belt Tension	1	1
20	9545-055-001	Bolt, Eye (1/4 -20x1/2)	1	1
21	8640-414-003	Nut, 1/4 Elastic Stop	1	1
22	9242-463-002	Overlow hose - 11 upper	1	1

* Not Illustrated

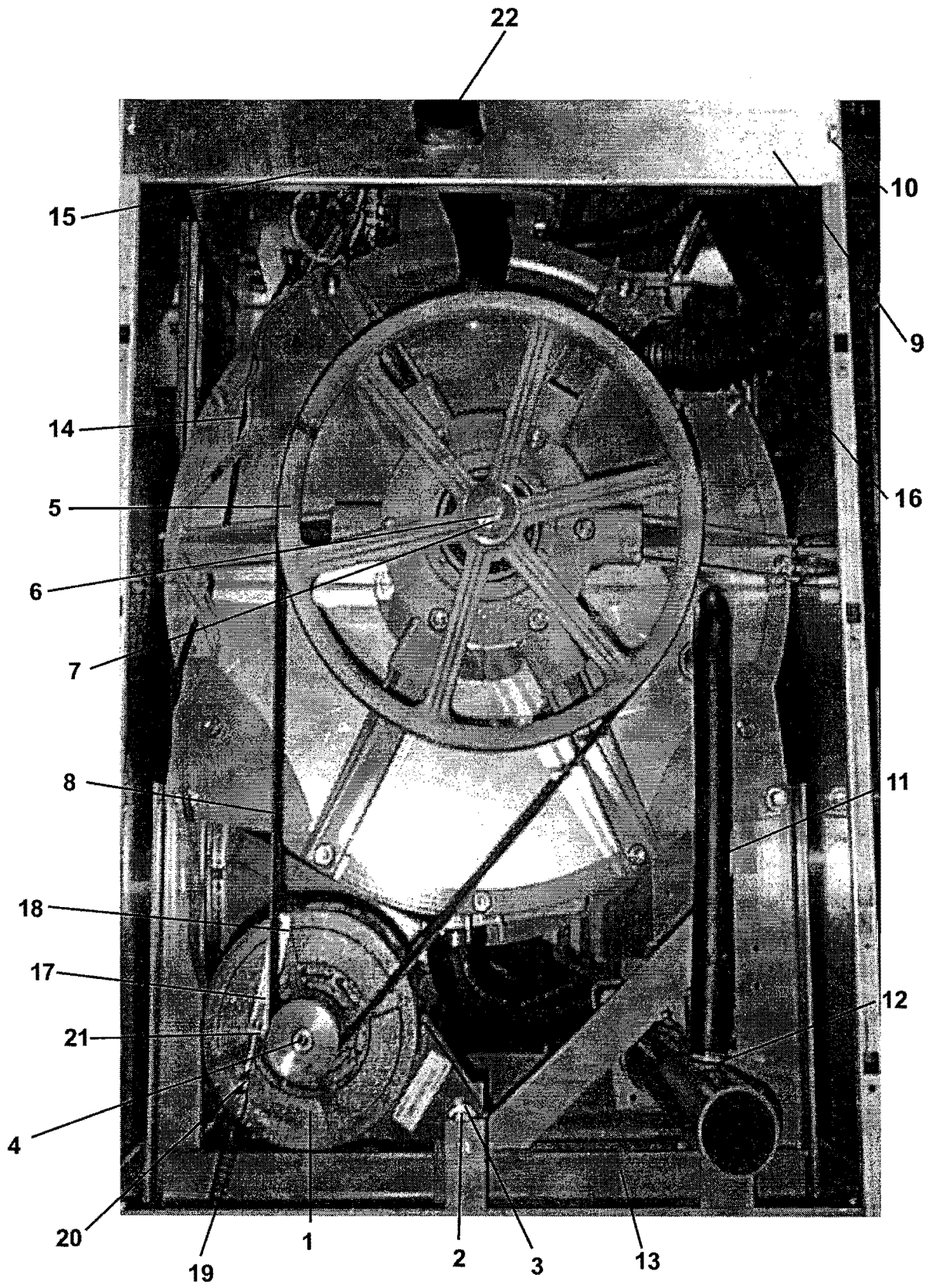

CHASSIS AND DRAIN GROUP

Key	Part Number	Description	MODELS	
			WCN25	
			A	A
			A	B
1	9945-087-002	Base Assy, Frame	1	1
2	9930-137-001	Tub Assy	1	1
2	9869-008-001	Tub & Cylinder Assy.....	1	1
2	9848-109-001	Cylinder Assembly only.....	1	1
3	9950-051-002	Ring Assy, Tub Mtg-Front	1	1
4	9545-017-003	Bolt, Top Front Ring (1/2 x 1 3/4)	1	1
4	8641-582-016	Lockwasher (1/2 ext tooth)	1	1
4	8640-417-002	Nut	1	1
5	9950-041-002	Ring Assy, Tub Mtg-Rear	1	1
6	9545-017-009	Bolt, Front & Rear Rings to Base (1/2 x 1 1/4)	4	4
6	8641-582-016	Lockwasher (1/2 ext. tooth)	4	4
6	8640-417-002	Nut	4	4
7	9379-187-001	Valve, Drain	1	1
8	9029-056-001	Bracket, Drain Valve	1	1
*	9545-048-001	Screw, Valve to Bracket	1	1
*	8641-581-018	Washer.....	1	1
9	9545-030-002	Screw, Bracket to Base.....	2	2
10	9915-119-002	Tube Assy, Drain	1	1
11	9545-030-002	Screw, Tube Mtg	2	2
12	9242-456-001	Hose, Tub to Drain Valve	1	1
13	9242-457-001	Hose, Drain Valve to Tube	1	1
14	8654-117-014	Clamp, Hose	4	4
*	9552-038-003	Shim, Support Assembly.....	AR	AR
*	9242-458-002	Hose, Vacuum Brkr. to Tub	1	1
20	9610-001-001	Vacuum Breaker	1	1
*	9029-065-001	Bracket, Vacuum Breaker	1	1
*	9545-008-026	Screw	4	4
21	9732-108-002	Dispenser KIT	1	1
22	9206-416-001	Gasket, Dispenser	1	1
*	9242-450-002	Hose, Dispenser to Tub	1	1
23	8654-117-008	Clamp, Dispenser Hose	2	2
15	9732-137-002	Back Assy. Tub	1	1
16	9991-048-002	Support Arm Assy., Bearing Hsg.	6	6
17	9545-029-003	Bolt, (3/8 x 1 1/2)	10	10
18	9545-029-006	Bolt, (3/8 x 1 3/4)	2	2
19	8640-415-004	Nut, Flange Lock.....	12	12

* Not Illustrated

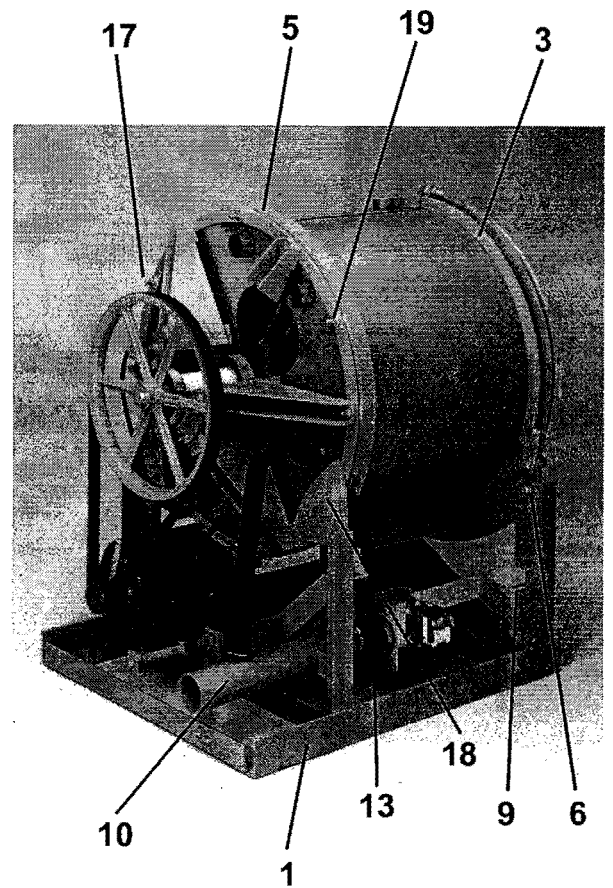
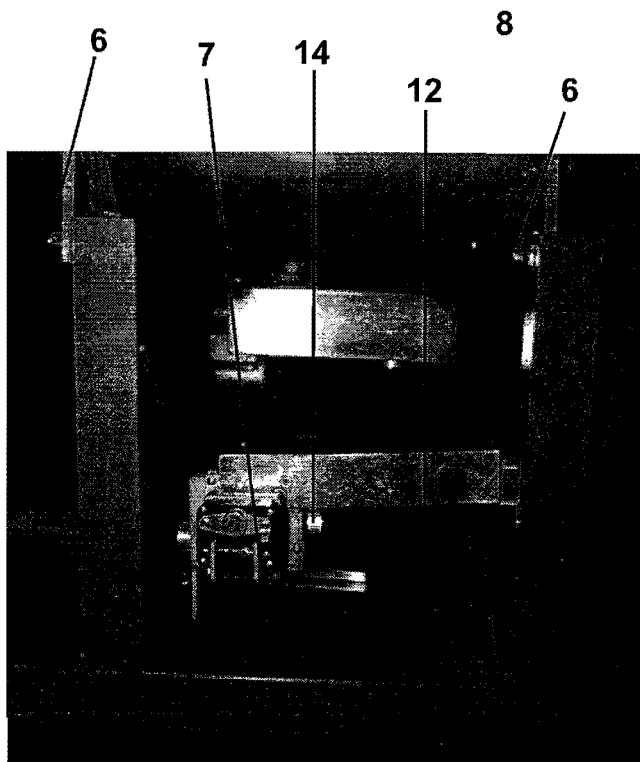
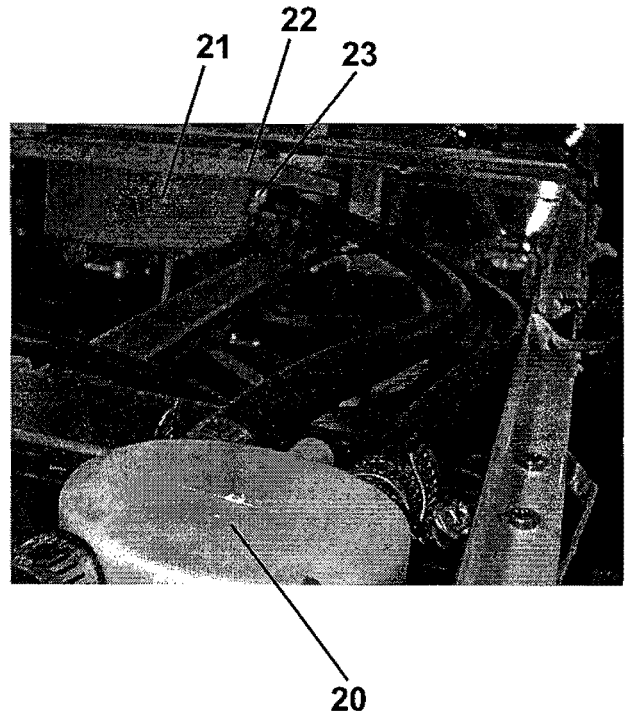
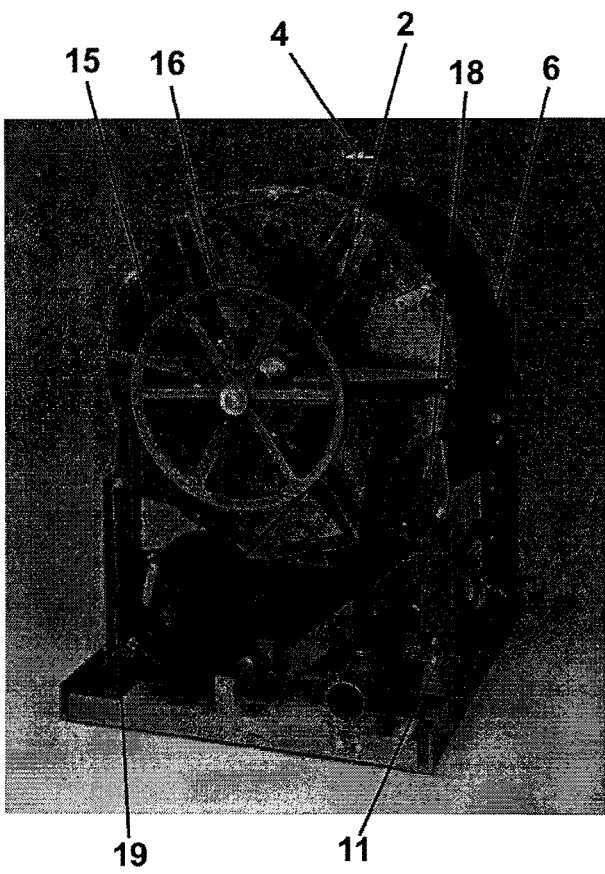

CYLINDER, WATER SEALS & BEARING HOUSING GROUP

Key	Part Number	Description	MODELS	
			WCN25	
			A	A
			A	B
*	9803-179-002	Housing, Bearing- Assembly (includes items #2-#6)	1	1
2	9241-169-002	Housing, Bearing	1	1
3	9036-159-002	Bearing, Front	1	1
4	9036-159-001	Bearing, Rear	1	1
5	9538-158-001	Spacer, Bearing	1	1
6	9487-238-001	Ring, Bearing Retainer (internal type)	1	1
7	9732-137-002	Back Assy, Tub	1	1
8	9532-140-003	Seal, Secondary	1	1
9	9532-140-002	Seal, Primary	1	1
10	9950-042-001	Ring, Seal Mtg	1	1
11	9487-261-002	Tub Back Mating Ring, (Between tub back and bearing housing)	1	1
12	9545-017-009	Bolt, 1/2" Tub End of Bearing Housing (1/2 x 1 1/4)	6	6
12	8640-417-002	Nut	6	6
12	8641-582-016	Lockwasher 1/2 (ext. tooth)	6	6
13	9991-048-002	Support Arm Assy., Bearing Housing	6	6
14	9545-029-003	Bolt Pulley End of Bearing Housing (3/8 x 1 1/2)	6	6
14	8640-415-004	Nut, Flange Locking 3/8	6	6
15	9453-168-002	Pulley, Driven old style single belt (before # 425720)	1	1
15	9453-168-004	Pulley, Driven new style double belt (after # 425720)	1	1
*	9487-234-001	Ring, Tolerance	1	1
16	8641-581-026	Washer 1/2	1	1
17	9545-017-009	Bolt 1/2 x 1 1/4)	1	1
18	8641-582-016	Lockwasher 1/2 Ext. tooth	1	1

* Not Illustrated

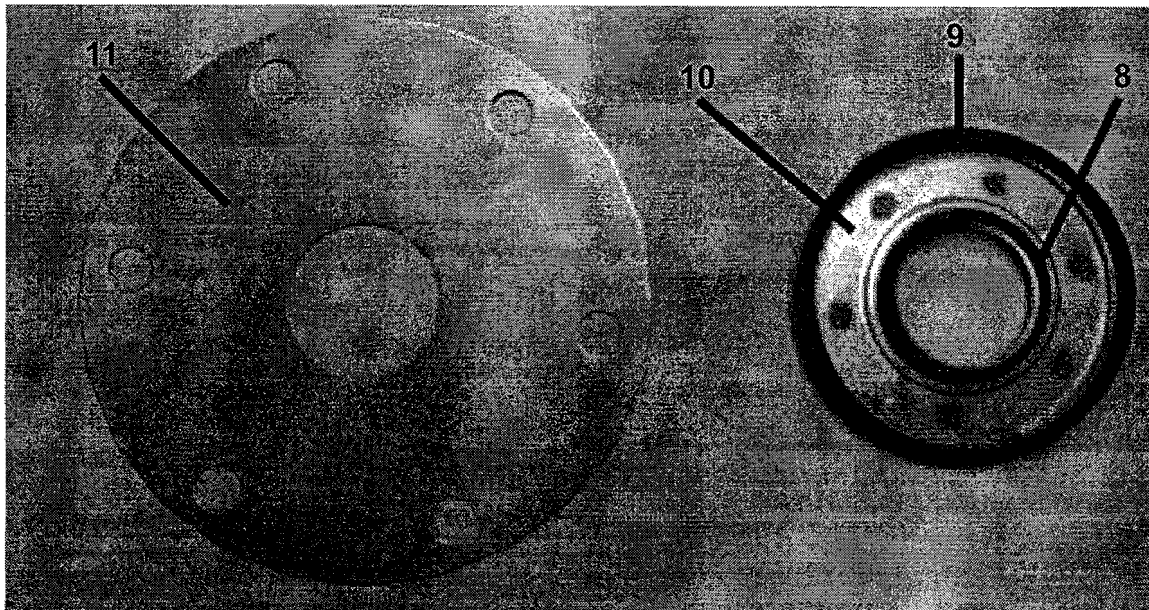

Cylinder, Waterseals, Bearing Housing and Pulley Group

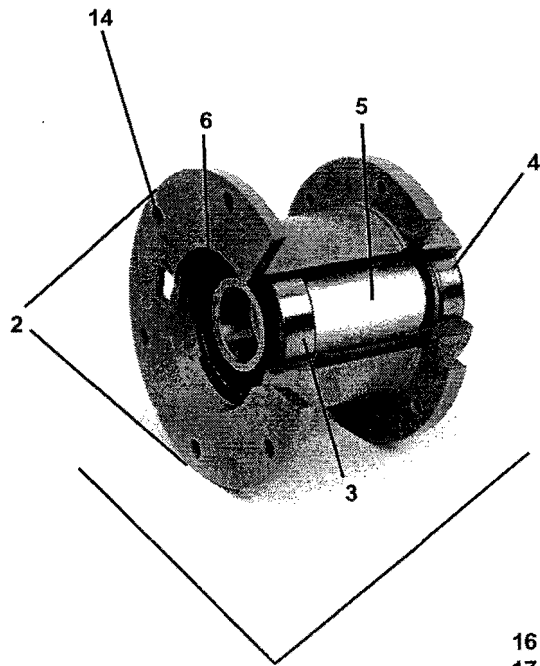
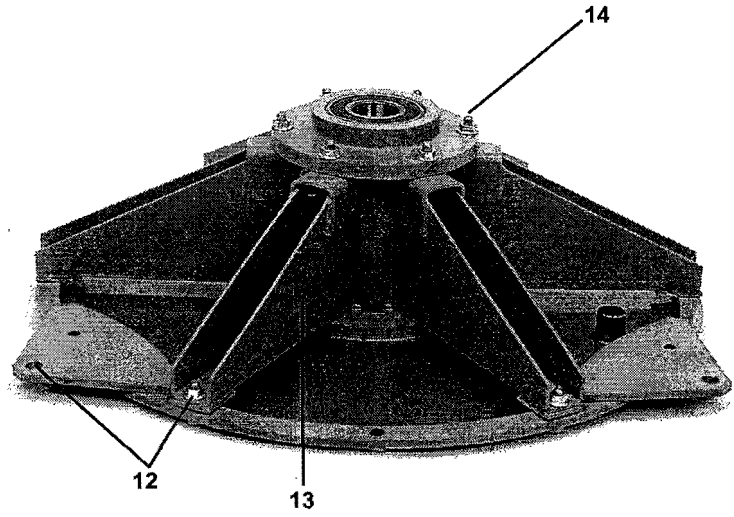

Housing Assembly

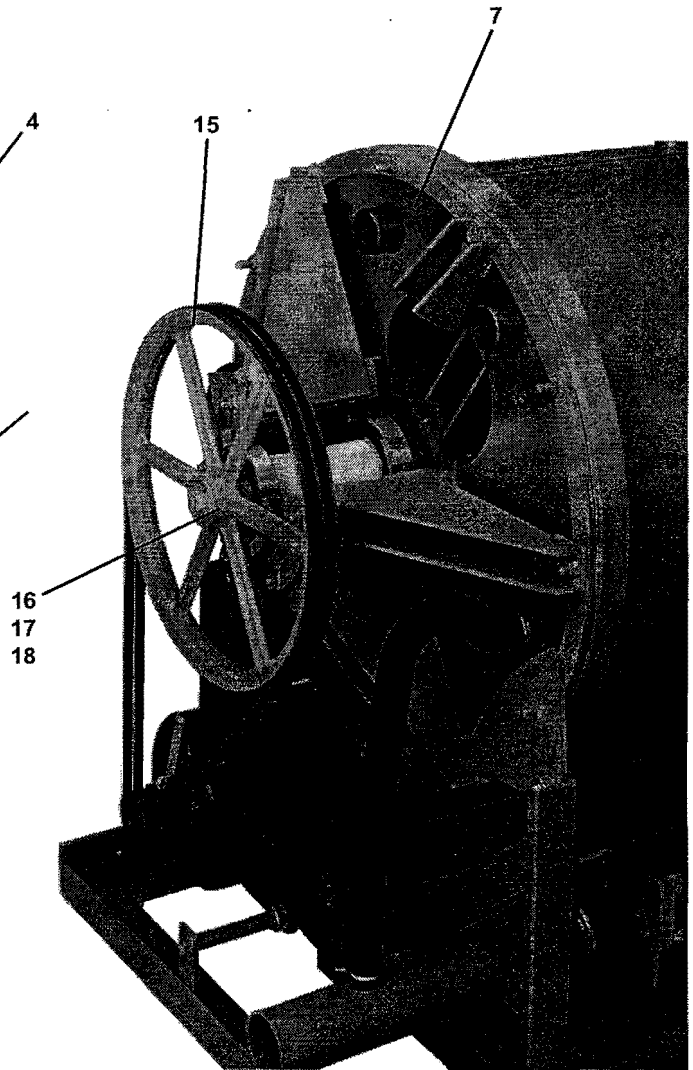

DOOR LOCK GROUP

MODELS
WCN25
A A
A B

Key	Part Number	Description	A	B
*	9885-023-001	Lock Assy, Complete (includes #1 thru #22)	1	1
1	9982-284-001	Plate Assy, Door Lock	1	1
2	8641-581-030	Washer, Flat	1	1
3	9008-005-001	Actuator, Latching Switch	1	1
4	9450-002-002	Pawl, Locking	1	1
5	8641-569-003	Washer, Spring	1	1
6	9487-200-004	Ring, Retaining	1	1
7	9029-035-001	Bracket, Switch	1	1
8	8640-413-002	Nut, Hex 10-32 UNF	2	2
9	9534-364-002	Spring, Actuating	1	1
10	9545-012-020	Screw, Hx. 10-32 x 1	1	1
11	8640-413-004	Nut, Elastic Stop 10-32	2	2
12	9534-364-001	Spring, Return	2	2
13	9451-193-001	Pin, Guide	1	1
14	9487-200-005	Ring, Retaining	1	1
15	8641-581-031	Washer	2	2
16	9539-461-008	Switch, Latching Sensing	1	1
17	9550-169-003	Shield, Switch	3	3
18	9545-020-001	Screw 4-40 x 5/8	2	2
18	8640-401-001	Nut, Twin	1	1
19	9539-461-007	Switch, Locking Sensing	2	2
20	9008-006-002	Actuator, Switch	2	2
21	9545-020-003	Screw 4-40 x 1 1/8	2	2
21	8640-401-001	Nut, Twin 4-40	1	1
22	9451-181-004	Pin, Dowel	1	1
*	9552-037-001	Shim, Door Lock, Thin	AR	AR
*	9552-037-002	Shim, Door Lock, Thick	AR	AR
*	9545-018-004	Screw, Lock mtg 1/4 -20 x 3/4	3	3
*	8641-582-007	Lockwasher 1/4 Ext tooth	3	3
*	9922-011-001	Solenoid Ass'y, Door Locking (includes 23 thru 32)	1	1
23	9029-073-001	Bracket, (Door Locking Solenoid)	1	1
24	9985-169-001	Bracket Ass'y, Solenoid Slide	1	1
25	9536-074-001	Solenoid 120V 60 hz	1	1
26	9545-008-001	Screw, Solenoid Mtg	4	4
27	9540-033-002	Stop, Door Lock Solenoid	1	1
28	9545-061-001	Screw, Shoulder	1	1
28	8640-411-003	Nut, Keps #6	1	1
29	9586-001-001	Thermoactuator 120 V	2	2
30	9545-031-011	Screw #6 x 5/16	4	4
31	9538-157-004	Spacer, Plastic	1	1
31	9538-166-004	Spacer, Metal	1	1
31	9545-010-001	Screw, Cross Recessed	1	1
31	8640-412-005	Nut, Keps #8	1	1
32	8640-411-003	Nut, Keps #6	1	1
*	8640-412-005	Nut, Sol. Brkt. to Control Panel	3	3
*	9497-225-006	Rod, Pull	1	1

* Not Illustrated

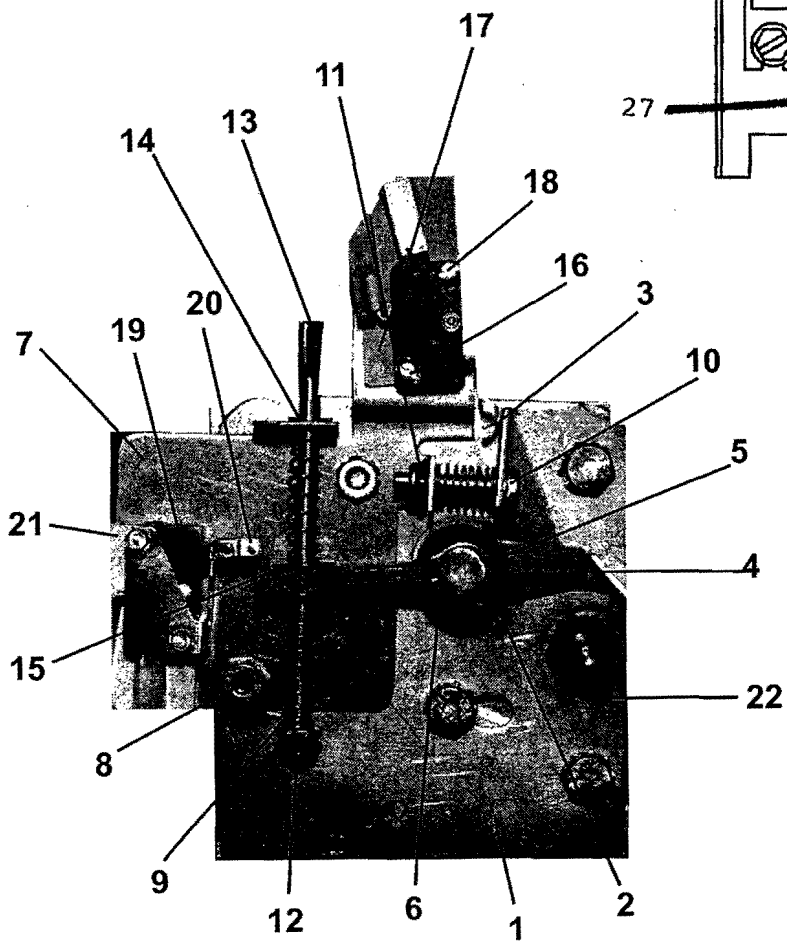
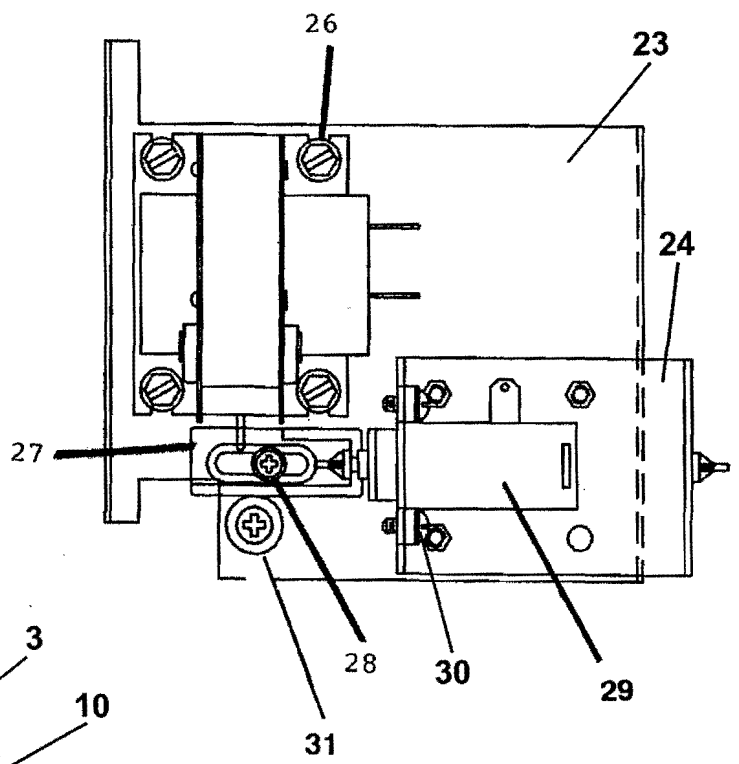
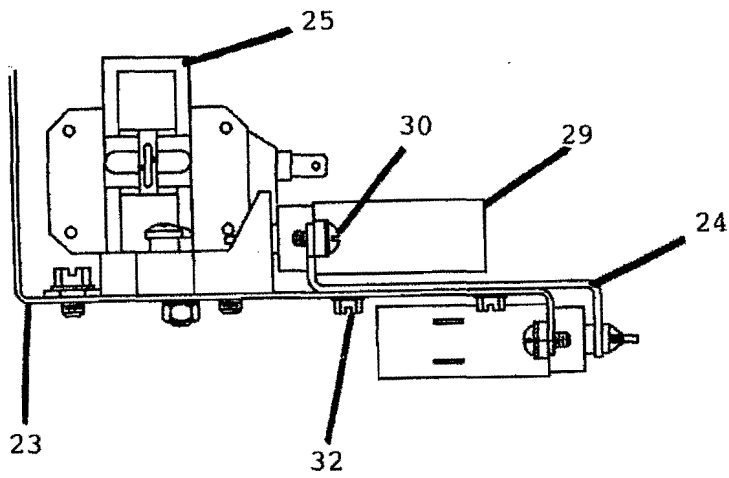

LOADING DOOR GROUP

Key	Part Number	Description	MODELS	
			WCN25	
			A	A
			A	B
*	9960-259-002	Loading Door, Complete (includes 1 thru 10)	1	1
1	9487-230-001	Loading Door, Ring	1	1
2	9206-419-001	Gasket, Loading Door	1	1
3	9635-016-001	Window, Loading Door	1	1
*	9913-134-003	Shaft Assy, Locking (includes 4 thru 7)	1	1
4	9537-195-002	Shaft, Door Locking	1	1
5	9095-040-001	Cam, Locking	1	1
6	9451-181-005	Pin, Groove (1 1/4).....	1	1
7	9451-181-004	Pin, Groove (3/4).....	1	1
8	9534-360-002	Spring, Lock Cam	1	1
9	9244-080-003	Handle, Door	1	1
*	9451-181-006	Pin, Door Handle (groove).....	1	1
10	9955-029-001	Loading Door Hinge Assy (mounts to Tub Front).....	1	1
*	9545-014-009	Screw, Hinge Mtg 5/16 x 3/4	3	3
*	8641-582-009	Lockwasher 5/16 Ext tooth	3	3
*	9552-036-001	Shim, Loading Door Hinge, Thin	AR	AR
*	9552-036-002	Shim, Loading Door Hinge, Thick	AR	AR
11	9451-184-003	Loading Door Hinge Pin(mounts inside Loading Door Hinge Assy)	1	1
15	8649-031-000	Ring, Retaining (snap ring ext)	1	1
12	9079-122-001	Loading Door Hinge Clamp (mounts to door ring)	1	1
13	9545-056-001	Screw, Loading Door Mtg 5/16 Theard Forming)	3	3
14	9487-254-001	Ring, Masking	1	1
*	9059-063-002	Band, Edge (mounts to Front Panel)	1	1
*	8640-413-002	Nut, Keps	4	4

* Not Illustrated

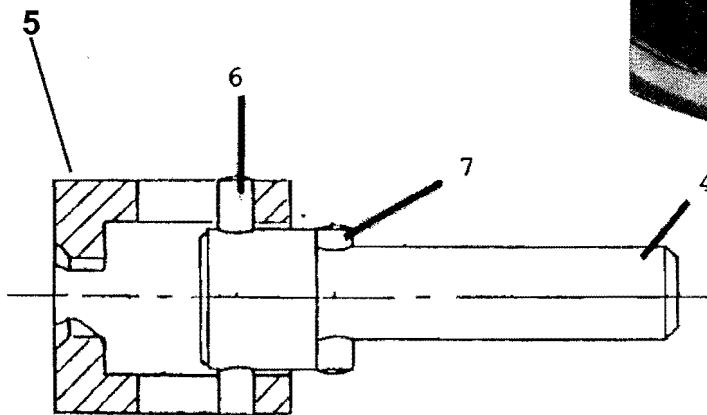
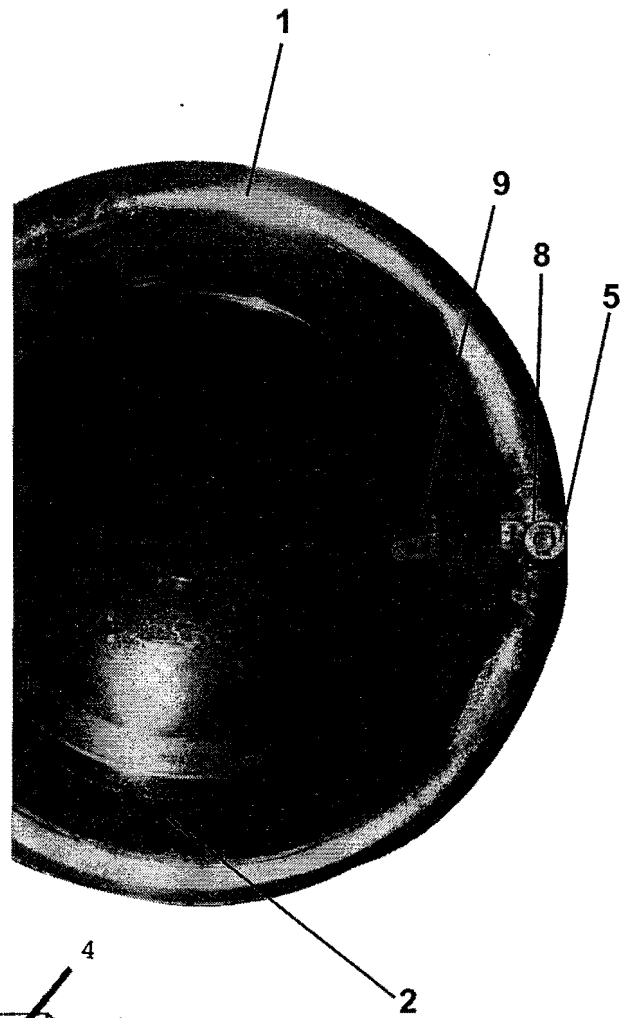
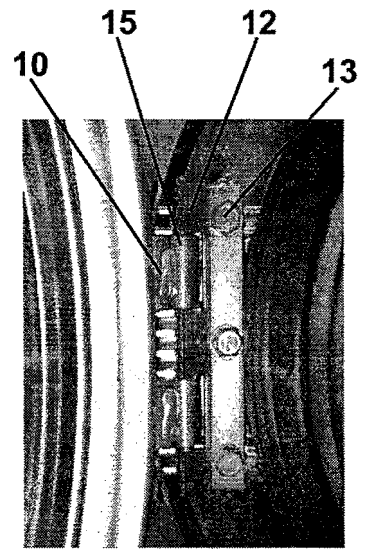
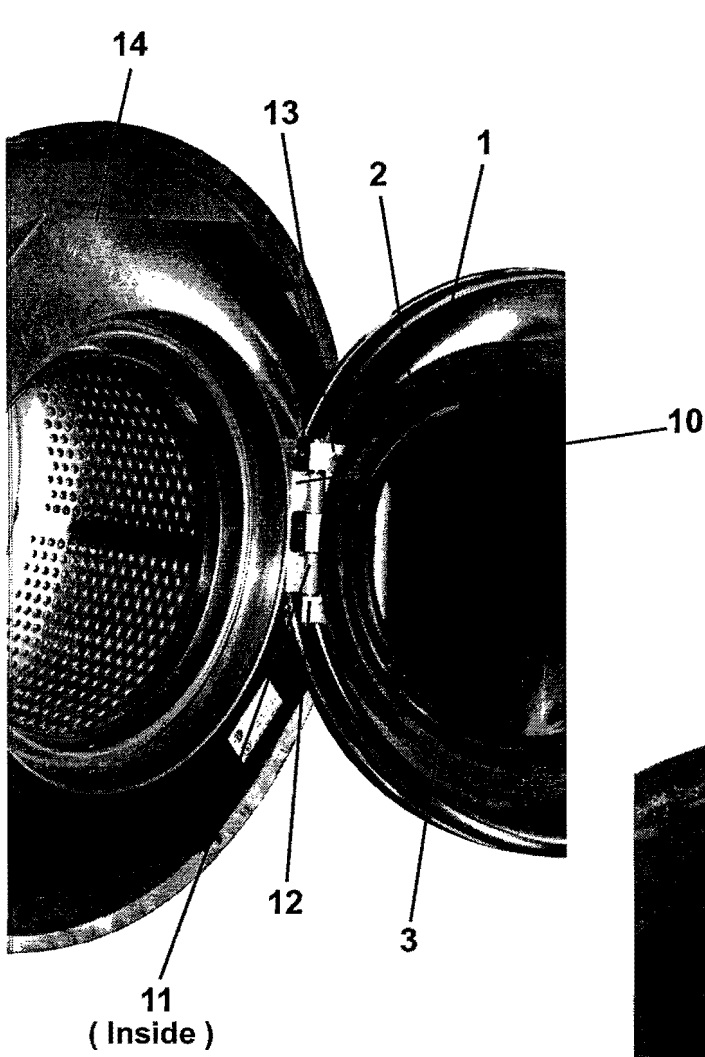

CONTROL PANEL GROUP

Key	Part Number	Description	MODELS	
			WCN25	
			A	A
			A	B
1	9539-479-009	Switch, Push-button (cycle selector)	1	1
*	8640-412-005	Nut, Switch Mtg	2	2
2	3310-041-001	Light, Cycle Control	1	1
*	9206-100-001	Gasket, Light	2	2
3	3310-042-001	Light, Bleach	1	1
4	9020-005-001	Accumulator, Coin with Time Remaining	1	1
*	9627-682-001	Wiring Harness, Accumulator	1	1
*	9538-157-005	Short Spacer #8x 1/8 (between board and shield)	3	3
5	9550-174-001	Shield, Circuit Board with Timer Remaining	1	1
*	8640-412-005	Nut, Hx	3	3
*	9538-157-003	Long Spacer (between panel and board)	3	3
6	9021-001-010	Acceptor, Coin (See Coin Handling Group).....	1	1
7	9732-122-001	Kit, Coin Box W/Hardware	1	1
8	9412-076-007	Nameplate, Control Panel (one piece).....	1	1
9	Solenoid Ass'y, Door Locking (see Door Lock Group for parts breakdown).....	1	1	1
*	8640-412-005	Hex Nuts (mounting solenoid assy. to control panel).....	3	3

* Not Illustrated

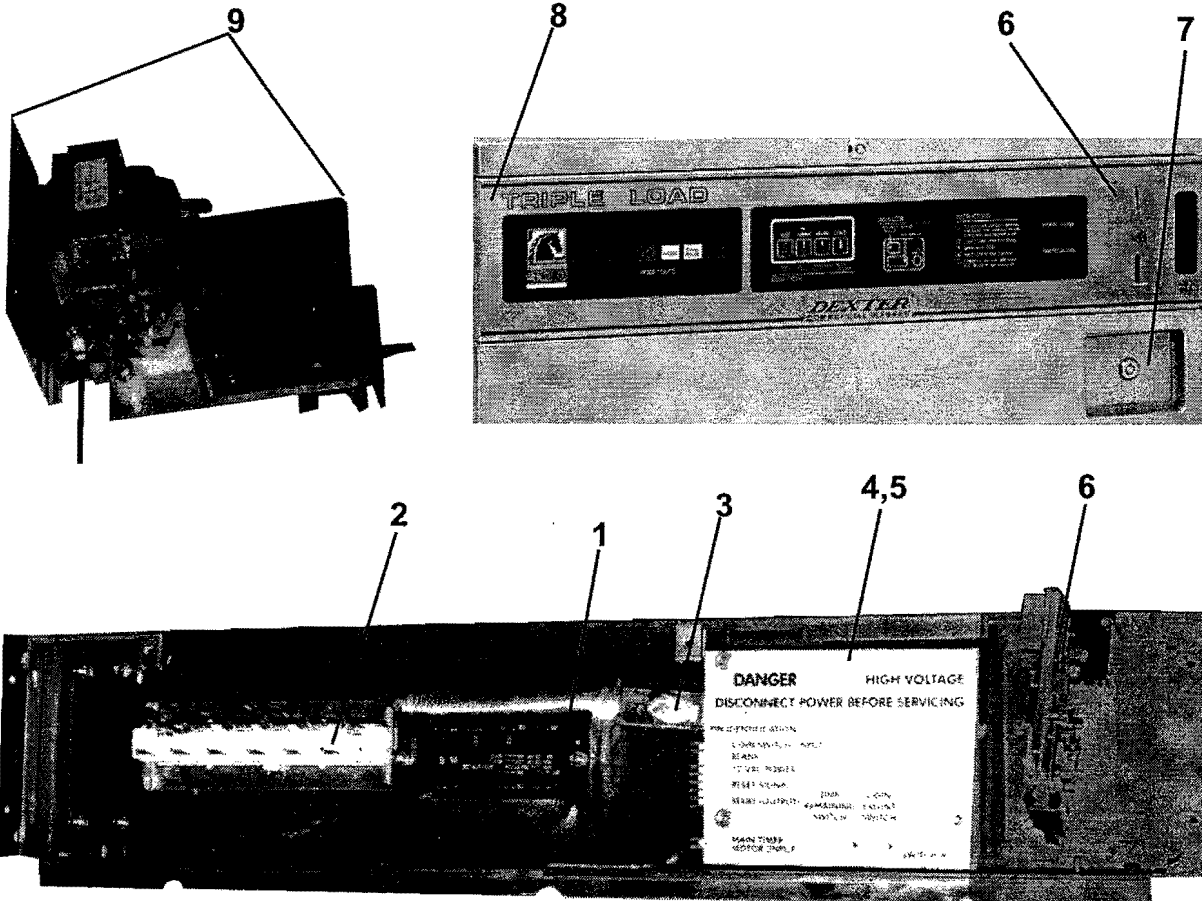

WATER INLET GROUP

Key	Part Number	Description	MODELS	
			WCN25	
			A	A
			A	B
1	9379-183-003	Valve, Water Inlet	2	2
		(see Water Inlet Valve Breakdown for individual parts)		
*	9545-008-026	Screw, Valve Mtg	4	4
*	8640-399-009	Nut, Spring	4	4
2	9029-065-001	Vacuum Breaker	1	1
*	9029-065-001	Bracket, Vacuum Breaker	1	1
3	9545-008-026	Screw	4	4
12	9242-458-002	Hose, Vacuum Breaker to Tub	1	1
*	8654-117-014	Clamp, Vacuum Breaker End	1	1
*	8654-117-009	Clamp, Tub End	1	1
4	9242-453-017	Hose, Vac. Brkr. to Wash Disp. 18 1/4	1	1
5	9242-453-016	Hose, Vac. Brkr. to Rinse Disp. 14 1/2	1	1
6	9242-453-020	Hose, Hot Valve to Vac. Brkr 18	1	1
7	9242-453-020	Hose, Hot Valve to Tub 18	1	1
8	9242-453-020	Hose, Cold Valve to Vac. Brkr 18	1	1
9	9242-453-020	Hose, Cold Valve to Tub 18	1	1
*	8654-029-000	Clamp, Hose-Spring (overflow from drain to tub back)	2	2
10	8654-117-015	Clamp, Hose-Worm	10	10
11	5198-211-004	Circuit Breaker	1	1

* Not Illustrated

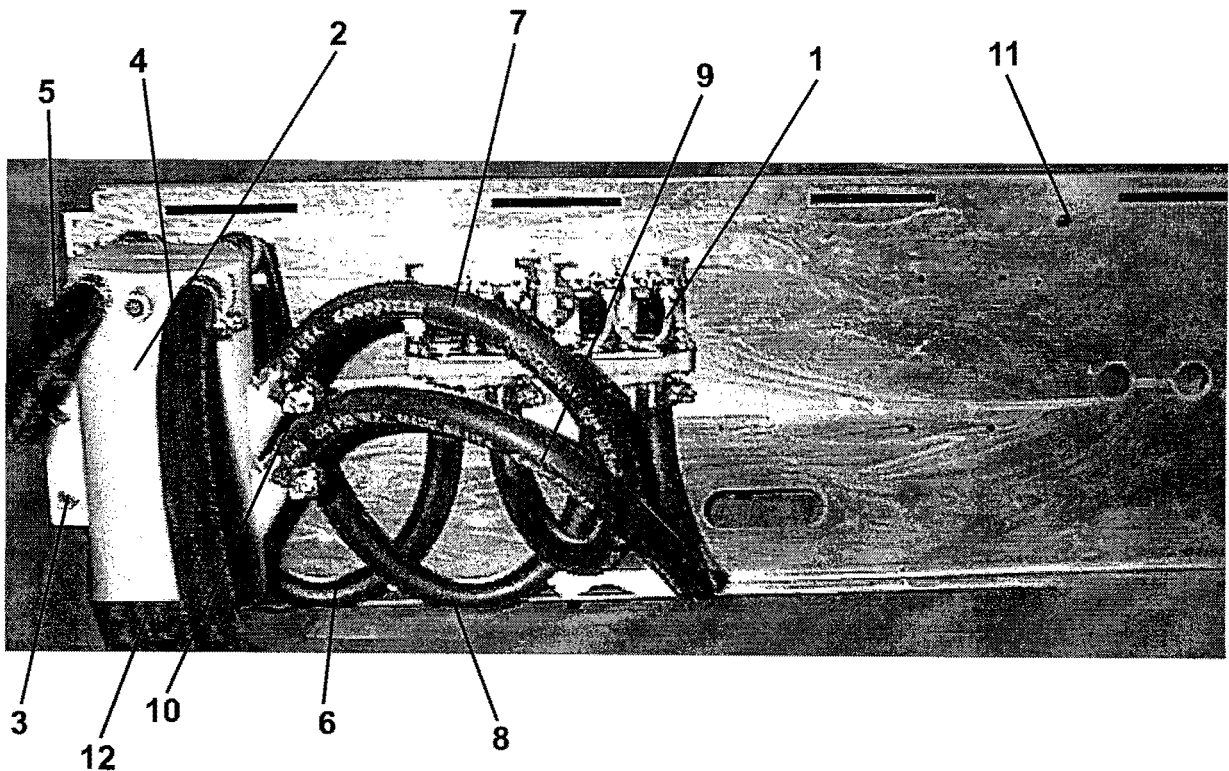

Electrical Components - Top Compartment

Single Phase Only

Key	Part Number	Description	MODELS	
			WCN25	
			A	A
			A	B
1	9839-012-003	Trough Assy, Controls Mtg	1	
*	9545-008-026	Screw, Trough Sides	2	
*	9029-064-001	Bracket, Trough to Rear Channel (not shown)	1	
*	9545-008-001	Screw, Trough Bracket	3	
3	5191-102-005	Capacitor, Spin-Start	1	
4	5191-103-010	Capacitor, Run-Tumble	1	
5	9544-049-002	Strap, Capacitor Mtg	1	
*	9545-045-001	Screw, Capacitor Strap	2	
6	5192-286-007	Relay, Tumble	2	
7	5192-286-008	Relay, Spin	1	
8	9571-362-001	Timer, Program	1	
	(VERIFY PART NUMBER ON TIMER BODY)			
*	9376-295-002	Motor, Timer Main Drive	1	
9	9376-286-004	Motor, Timer Rapid Advance	1	
*	9545-012-001	Screw, Timer Mtg	2	
10	9107-068-001	Dial, Timer Label	1	
11	9307-176-001	Knob, Timer (w/set screws)	1	
12	9571-360-001	Timer, Reversing 115 V	1	
*	9545-044-004	Screw, Reversing Timer	2	
13	9897-035-001	Terminal Block, Power Connection 4 pole	1	
*	9545-045-007	Screw, Mtg	2	
*	8502-619-003	Label, Fusing & Installation	1	
14	9897-029-001	Terminal Block Assy, 12 Lug	1	
*	9545-045-007	Screw, Mtg	2	
*	9558-022-001	Strip, Terminal Marker	1	
15	9539-457-001	Switch, Pressure	1	
*	9545-045-001	Screw, Mtg	2	
16	5198-211-004	Circuit Breaker, 1.5 amp	1	
17	8652-130-037	Lug, Grounding	1	
*	8639-621-007	Screw, Mtg	1	
*	8641-582-006	Lockwasher	1	
18	9539-478-002	Solid State Start Switch	1	
*	9029-062-001	Strap, Mtg	1	
*	9545-010-001	Screw	1	
*	8640-412-005	Nut	1	
*	9545-031-003	Screw, Mtg Strap to Control Trough	3	
19	8711-003-001	Transformer, (For Accumulator) 120/24 VAC	1	
*	9545-045-001	Screw, Transformer Mtg	2	
*	8641-582-005	Lockwasher	2	

* Not Illustrated

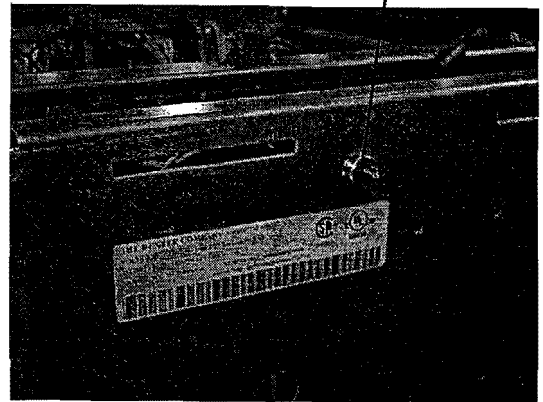
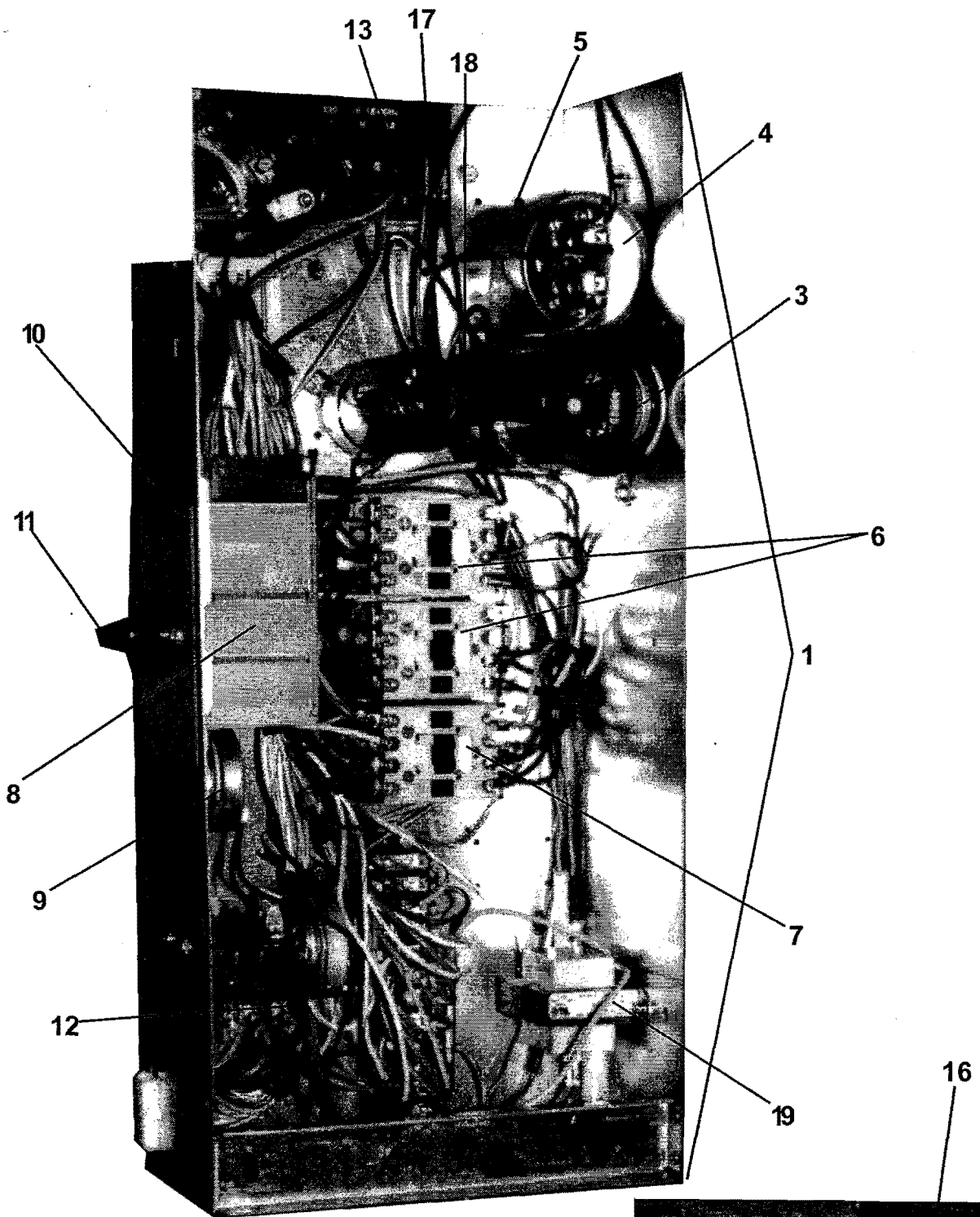

Electrical Components - Top Compartment

Three Phase Only

Key	Part Number	Description	MODELS	
			WCN25	
			A	A
			A	B
1	9839-012-003	Trough Assy, Controls Mtg		1
*	9545-008-026	Screw, Trough Sides		2
*	9029-064-001	Bracket, Trough to Rear Channel (not shown)		1
*	9545-008-001	Screw, Trough Bracket.....		3
3	5192-286-007	Relay, Tumble		2
4	5192-286-009	Relay, Spin		1
5	8711-004-001	Transformer, Control		1
*	8507-230-001	Transformer Instructions		1
*	9545-008-005	Screw, Mtg		1
*	8641-582-006	Lockwasher		1
6	9571-362-001	Timer, Program		1
	(VERIFY PART NUMBER ON TIMER BODY)			
*	9376-295-002	Motor, Timer Main Drive		1
7	9376-286-004	Motor, Timer Rapid Advance		1
*	9545-012-001	Screw, Timer Mtg		2
8	9107-068-001	Dial, Timer Label		1
9	9307-176-001	Knob, Timer (w/set screws)		1
10	9571-360-001	Timer, Reversing		1
*	9545-044-004	Screw, Reversing Timer		2
11	9897-035-002	Terminal Block, Power Connection 4 pole		1
*	9545-045-007	Screw, Mtg		2
*	8502-619-004	Label, Fusing & Installation.....		1
12	9897-029-001	Terminal Block Assy, 12 Lug		1
*	9545-045-007	Screw, Mtg		2
*	9558-022-001	Strip, Terminal Marker		1
13	9539-457-001	Switch, Pressure		1
*	9545-045-001	Screw, Mtg		2
14	5198-211-004	Circuit Breaker, 1.5 amp		1
15	8652-130-037	Lug, Grounding		1
*	8639-621-007	Screw, Mtg		1
*	8641-582-006	Lockwasher.....		1
16	8711-003-001	Transformer, (For Accumulator)		1
*	9545-045-001	Screw, Transformer Mtg.....		2
*	8641-582-005	Lockwasher		2

* Not Illustrated

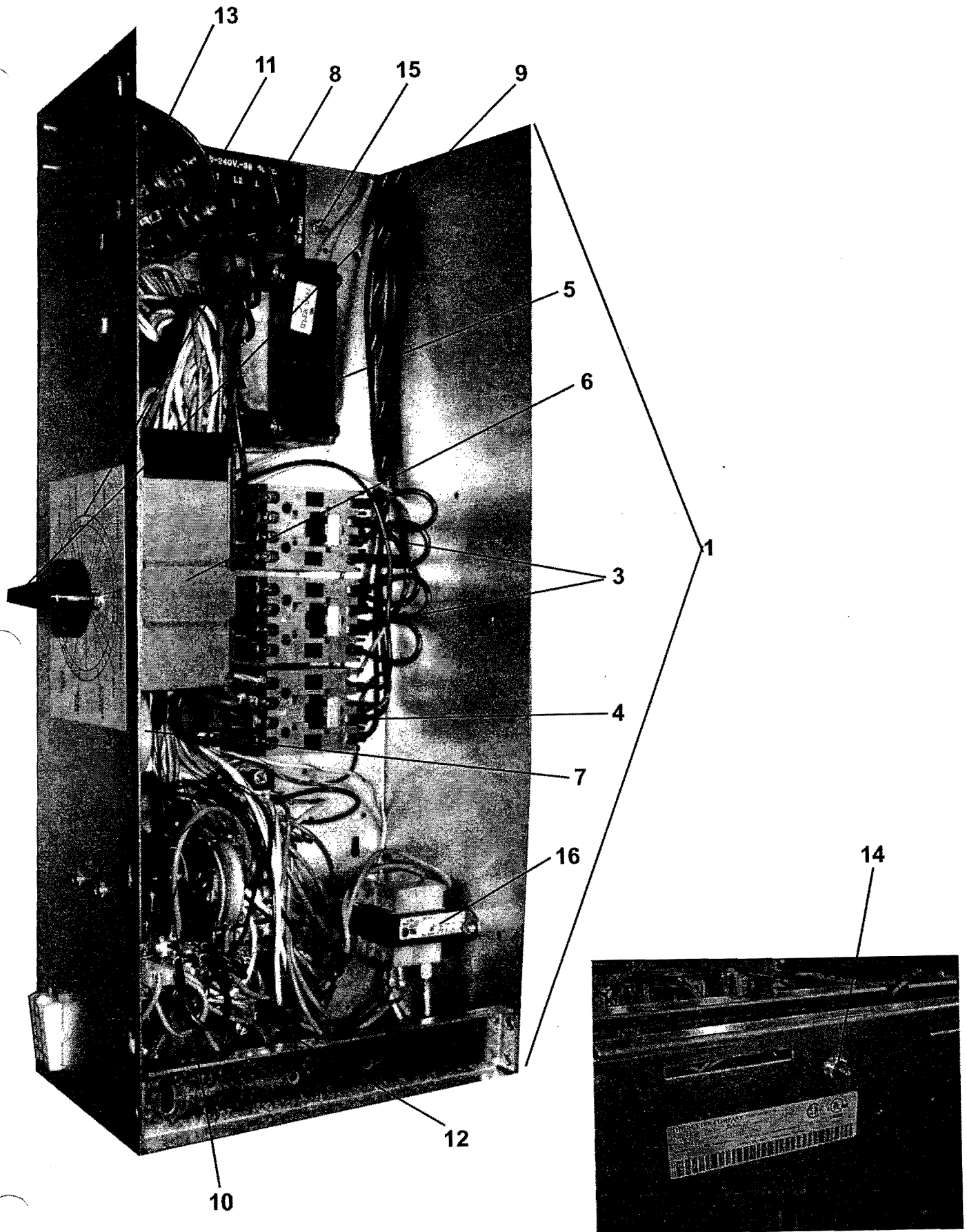

Coin Handling Group

Key	Part Number	Description	MODELS	
			WCN25	
			A	A
			A	B
1	9942-026-005	Vault, Assy	1	1
*	9545-008-026	Screw, Vault Mtg	4	4
NOTE: COIN BOX AND HARDWARE KIT AND COIN BOX LOCK NOT INCLUDED WITH MACHINE.				
2	9732-122-001	Kit, Coin Box W/Hardware (includes 3 thru 6)	1	1
3	9349-033-001	Latch, Coin Box	1	1
4	8641-569-002	Washer, Wave	1	1
5	8641-583-001	Washer, Keeper	1	1
6	8641-581-008	Washer, Spacer- Thick	2	2
6	8641-581-010	Washer, Spacer- Thin	4	4
7	8650-012-003	Lock, Coin Box (w/key)	1	1
8	9940-014-004	Chute Assy., Coin	1	1
*	9545-008-001	Screw, Chute Mtg	1	1
11	9119-025-002	Coin Acceptor chute without penny rejector (standard)	1	1
9	9021-001-010	Acceptor, Coin.....	1	1
*	9545-020-002	Screw, Acceptor Mtg.....	4	4
*	8640-424-002	Nut.....	4	4
10	9732-126-001	Switch, Coin.....	1	1
12	9119-025-001	Coin Acceptor chute with penny rejector (optional)	optional	
13	9486-133-001	Button Coin Return retainer	1	1

* Not Illustrated

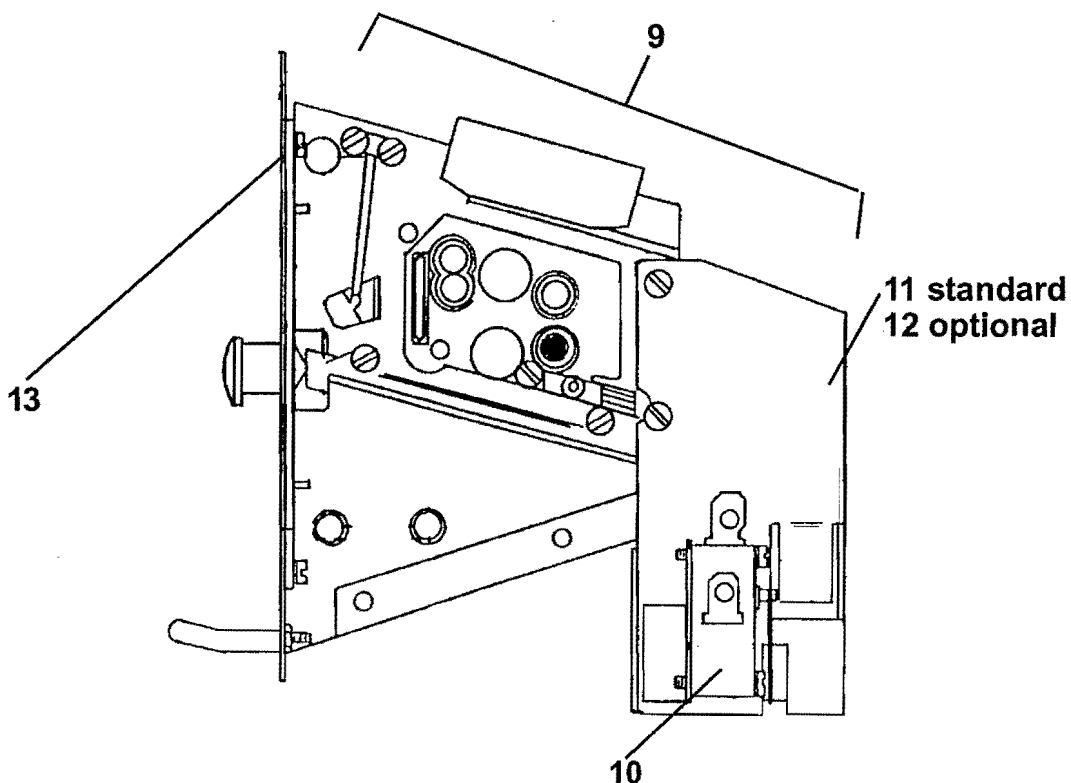

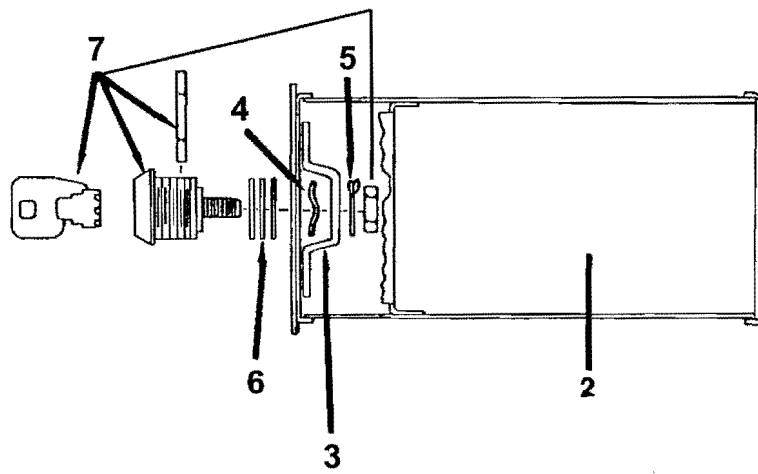
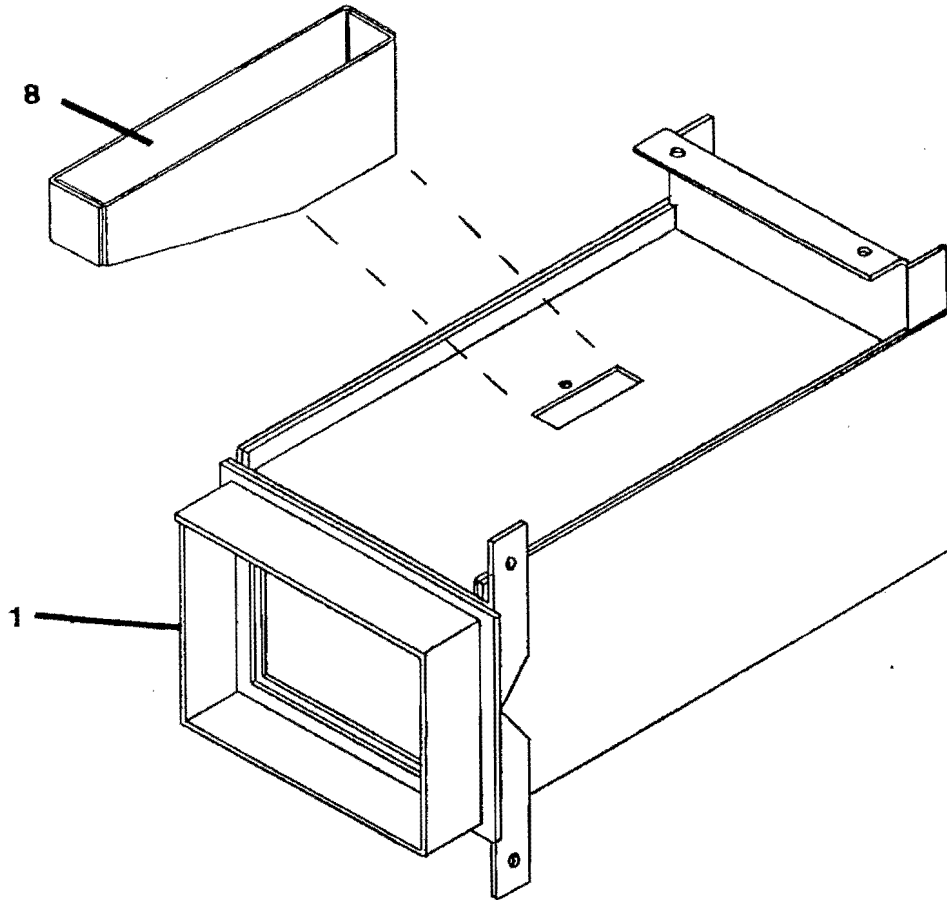

Water Inlet Valve Breakdown

MODELS
WCN25

A A
A B

Key	Part Number	Description	2	2
*	9379-183-003	Valve, Water Inlet Blue (includes 1 thru 6)	2	2
1	9555-056-001	Screen, Inlet (in valve)	2	2
2	9089-017-001	Coil Assy., 120 V	2	2
3	9118-049-001	Diaphragm	2	2
4	9211-021-002	Guide, Solenoid	2	2
5	9015-008-001	Armature	2	2
6	9534-298-001	Spring, Armature	2	2
*	9545-008-026	Screw, Valve Mtg	2	2

* Not Illustrated

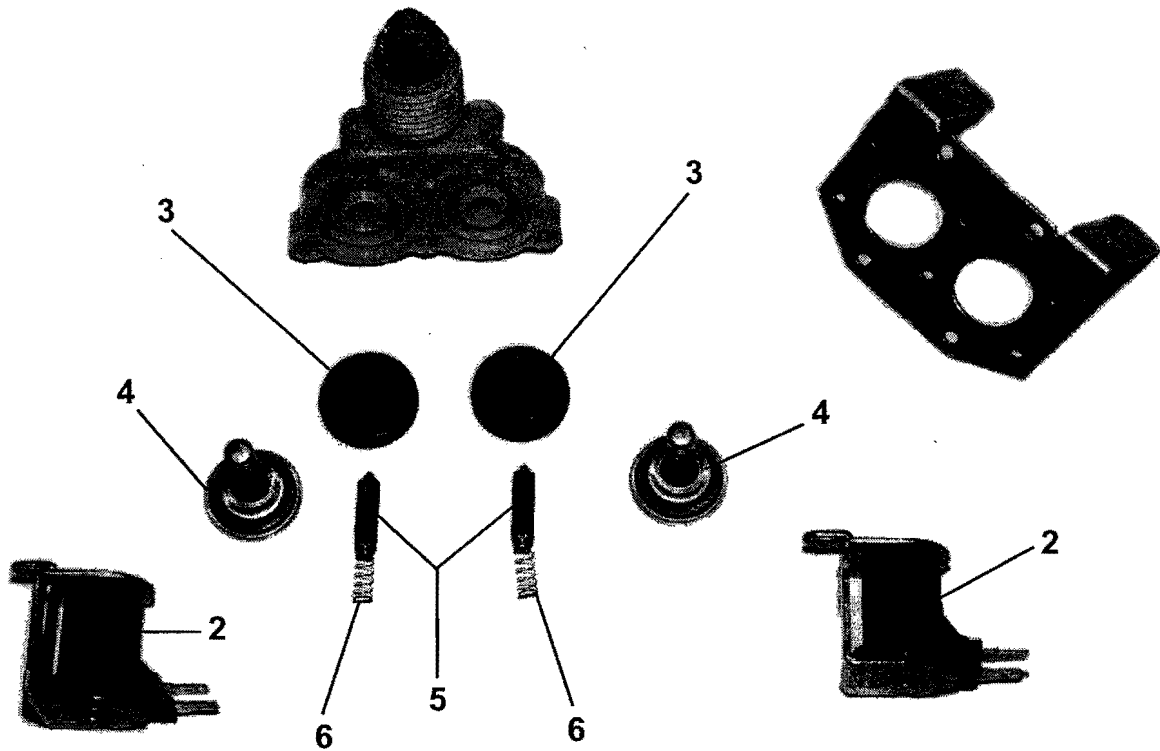

DRAIN VALVE GROUP

MODELS WCN25

A A
A B

Key	Part Number	Description		
*	9379-187-001	Valve, Drain (includes 2 thru 11) (3)	1	1
2	9064-070-001	Body, Valve (w/ball)	1	1
3	9914-137-001	Motor & Gear Train	1	1
4	9452-538-001	Plate, Motor Mtg	1	1
5	8639-994-001	Screw	3	3
6	9534-339-001	Spring, Drive	1	1
7	9545-054-001	Screw	2	2
8	9545-054-002	Screw	1	1
9	9532-134-001	Seal, V Packer	2	2
10	8641-584-001	Washer	1	1
11	9451-196-001	Pin, Main Drive	1	1
12	9538-149-001	Plate (spacers needed for replacement motor mtg. plate)	4	4

* Not Illustrated

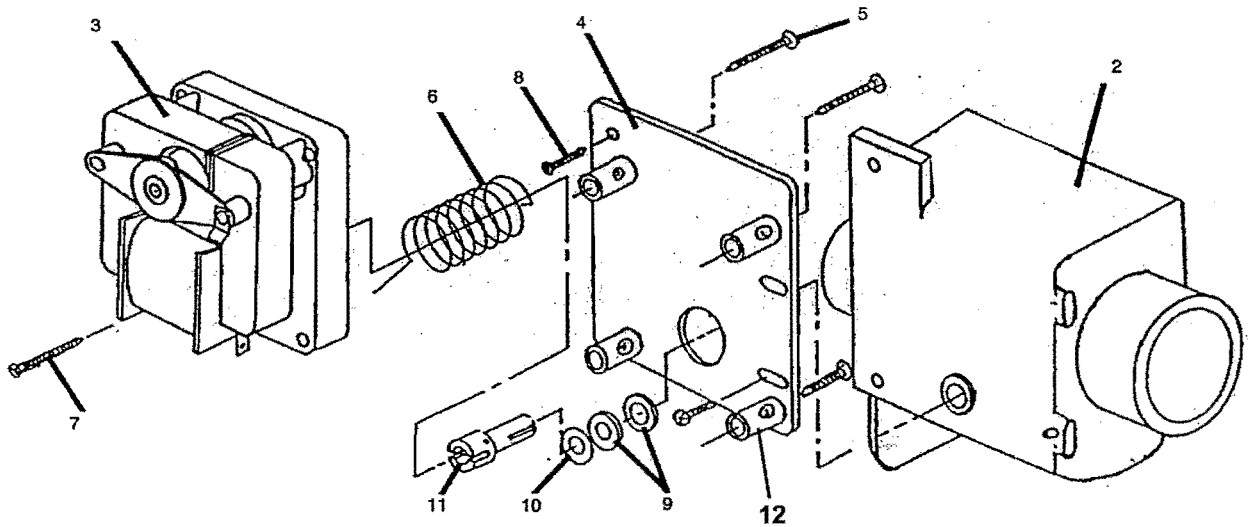

Valve
Complete

WIRING HARNESS GROUP

MODELS
WCN25
A A
A B

Key	Part Number	Description		
USE FOLLOWING TWO ITEMS WITH TIMER PART NUMBER 9571-359-002				
	9627-680-002	Wiring Harness, Main	1	1
	9627-681-003	Wiring Harness, Control	1	1
	9627-682-001	Wiring Harness, Coin accumulator	1	1
	9627-683-001	Wiring Harness, Drain Valve	1	1
	8654-125-001	Clamp, Cable- 1/4 Dia.	1	1
	8653-074-001	Connector, Clear In-Line	AR	AR
USE FOLLOWING ITEMS WITH TIMER PART NUMBER 9571-362-001				
	9627-683-001	Wiring Harness , Drain Valve	1	1
	9627-689-001	Wiring Harness , Control	1	1
	9627-695-001	Wiring Harness , Main	1	1
	9627-708-001	Wiring Harness , Countdown	1	1
	9627-682-001	Wiring Harness , Coin Accumulator	1	1

LABELS AND DIAGRAMS

9345-789-004	Wiring Diagram	(3 phase)
9345-788-004	Wiring Diagram	(1 phase)
9345-787-002	Wiring Schematic	(1 ph / 3 ph)
8502-614-004	Label High Voltage Warning	
8502-619-003	Label Fusing & Installation	(1 phase)
8502-619-004	Label Fusing & Installation	(3 phase)
8502-620-001	Label Motor Connections	
8502-230-001	Label Transformer Connections	(3 phase)
8502-624-002	Label Door Opening Warning	
8502-639-001	Label Warning	
8511-001-002	Label Quality	
8514-019-002	Owners Booklet	
8507-274-001	Spin Direction Label	