



# Section 6

## Parts Data

### CABINET GROUP

Key	Part Number	Description	
*	9960-256-021	Door Assy., Loading Complete-Wht .....	1
*	9960-256-025	Door Assy., Loading Complete-SS .....	1
1	9960-255-007	Door Assy., Loading-SS .....	1
2	9982-280-002	Plate Assy., Hinge (Wht) .....	1
2	9982-280-011	Plate Assy., Hinge (SS) .....	1
*	9545-012-015	Screw, Hinge to Door 10-32 x 3/8" .....	4
*	8640-413-002	Nut, Hinge to Door #10-32 UNF .....	4
3	9212-002-003	Glass, Door .....	1
4	9206-164-009	Gasket, Glass .....	1
*	9548-117-000	Support, Door Glass (inside gasket) .....	1
5	9206-420-002	Gasket, Outer Rim .....	1
6	9244-082-001	Handle, Loading Door .....	1
*	9545-018-017	Screw, Handle 1/4"-13 x 1 1/4" .....	2
*	9531-033-001	Stud, Door Catch .....	1
*	8640-413-001	Nut, Hex .....	
*	8640-413-003	Nut , Acorn # 10-32 .....	1
*	9086-015-002	Catch, Loading Door .....	1
7	9989-460-003	Panel Assy., Front- white .....	1
7	9989-460-001	Panel Assy., Front- S. Steel .....	1
8	9108-100-001	Door, Upper Service-S.S .....	1
8	9108-100-003	Door, Upper Service-White .....	1
9	9578-090-002	Trim, Door-Upper Service .....	1
*	6292-006-006	Key ( only ) (FJWCC) .....	1
10	8650-006-003	Lock w/ nut, Upper Service Door .....	1
*	8638-211-001	Rivet, Drive .....	2
*	8641-581-005	Washer, Flat 3/16" .....	2
*	9548-243-002	Support, Upper Door .....	1
11	9412-083-001	Nameplate, Commercial Dryer .....	1
12	9545-012-003	Screw, Chrome 10-32 x 1/2" .....	4
*	8641-436-004	Washer, Fiber .....	4
*	8641-582-019	Lockwasher # 10 .....	10
*	8640-399-001	Nut, Spring U type 10Z .....	6
13	9544-047-002	Strap, Hinge (White) .....	1
13	9544-047-007	Strap, Hinge (Gray) .....	1
*	9545-008-008	Screw, Hinge to Panel 10T-32 x 1/2" .....	4
14	9545-052-001	Screw, Door to Hinge Strap (special) .....	1
*	8641-436-003	Washer, Fiber/ Plastic .....	1

\* Not Illustrated

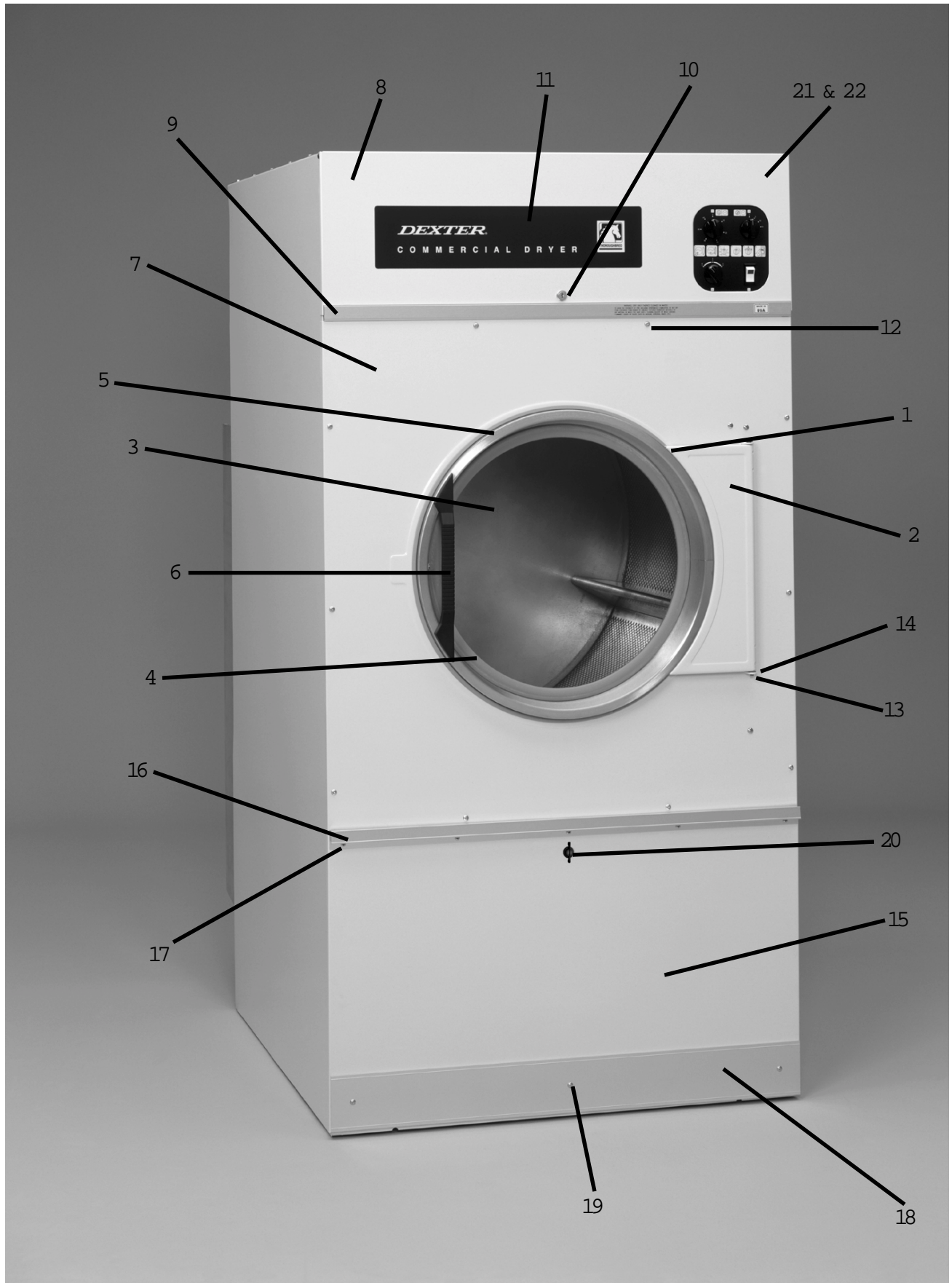

## CABINET GROUP (continued)

Key	Part Number	Description	
15	9960-261-003	Door Ass'y, Lower Service-SS .....	1
15	9960-261-001	Door Ass'y, Lower Service-White .....	1
16	9578-088-001	Trim, Door - Lower Service .....	1
17	9545-008-021	Screw,Pn Hd Cr., #10Bx3/8 .....	5
18	9578-084-002	Trim, Kick- Lower Service Door .....	1
19	9545-008-010	Screw, Tr Hd Cr-#10x1/2 Blk .....	3
20	8650-026-001	Latch, Lower Door (Thumbturn).....	1
*	8544-005-000	Leg, Leveling .....	4
*	9049-074-001	Baffle, Cabinet- Left .....	1
*	9049-074-002	Baffle, Cabinet- Right.....	1
*	9545-008-003	Screw, #10x1/2 TEK .....	8
21	9074-273-001	Cover, Cabinet .....	1
22	9545-008-024	Screw .....	10

\* Not Illustrated

THE DEXTER

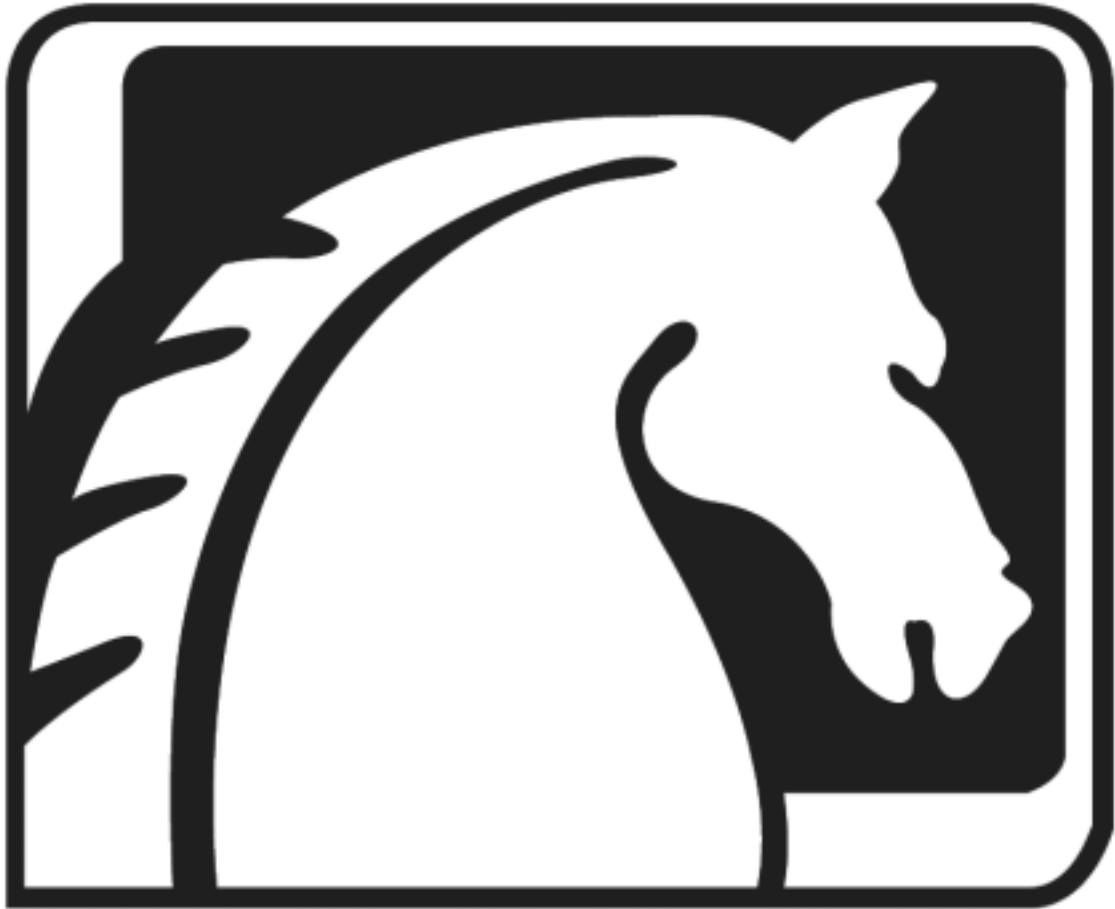

COMPANY

## CONTROL HOUSING GROUP

Key	Part Number	Description	
1	9571-350-004	Timer, Dry Time .....	1
2	9571-350-004	Timer, Cool-down Time .....	1
3	9307-176-001	Knob, Timer .....	3
*	9545-010-003	Screw, Hx #8-32x3/16 .....	4
4	9539-460-002	Switch, Push-To-Start .....	1
5	9576-209-001	Thermostat, Temp. Control .....	1
6	9029-085-001	Bracket, Thermostat .....	1
7	9307-176-001	Knob, Temperature Control .....	1
*	9545-045-008	Screw, #8 Abx3/8 .....	6
*	9029-088-001	Bracket, Bulb Mtg .....	1
*	9079-121-002	Clamp, Tube .....	1
8	9452-666-002	Plate Assembly,Control Mounting .....	1
9	9451-146-005	Pin- Hinge meterplate .....	2
10	8527-114-001	Decal, Control Panel .....	1
11	8636-018-001	Fuse .....	1
12	9054-045-001	Fuseholder .....	1
13	9857-116-00	Control, Ignition .....	1
14	9631-403-003	Wire Ass'y High Voltage .....	1

\* Not Illustrated

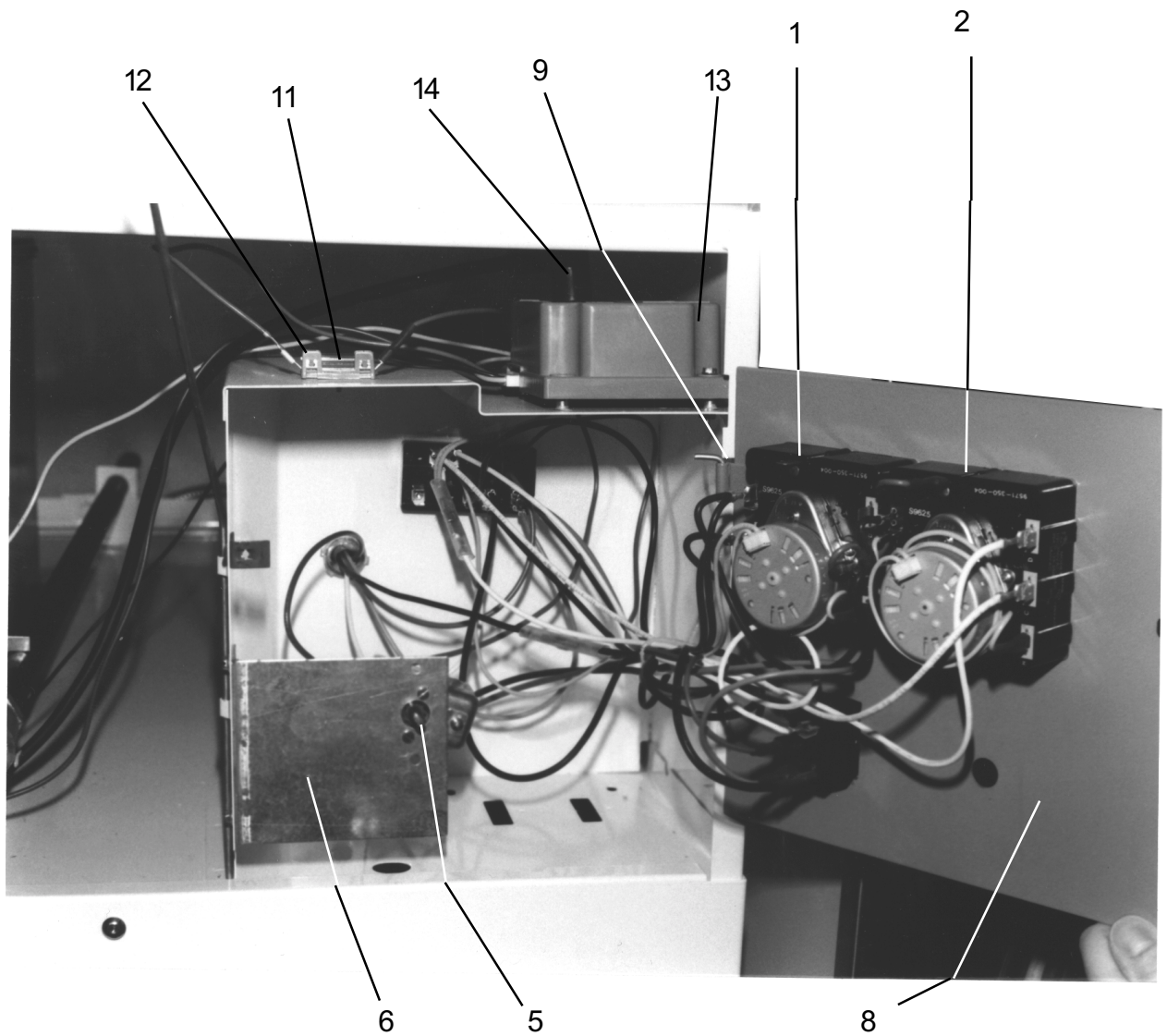

# DOOR SWITCH GROUP

Key	Part Number	Description	
1	9041-076-001	Box, Door Switch .....	1
2	9550-159-001	Shield, Door Switch .....	1
3	9539-461-001	Switch, Door .....	1
4	8640-401-001	Nut, Special Twin .....	1
5	9545-020-001	Screw, Pn Hd Sl.#4-40x5/8 .....	2
6	9074-255-001	Cover, Switch Box .....	1
7	9545-008-020	Screw, Box Cover .....	2
8	9008-004-001	Actuator, Switch- Lower .....	1
9	6068-041-001	Conduit .....	1
10	9545-012-003	Screw.....	2
*	8641-436-000	Washer, Fiber .....	1
11	8640-413-004	Nut, Elastic Stop .....	2

\* Not Illustrated

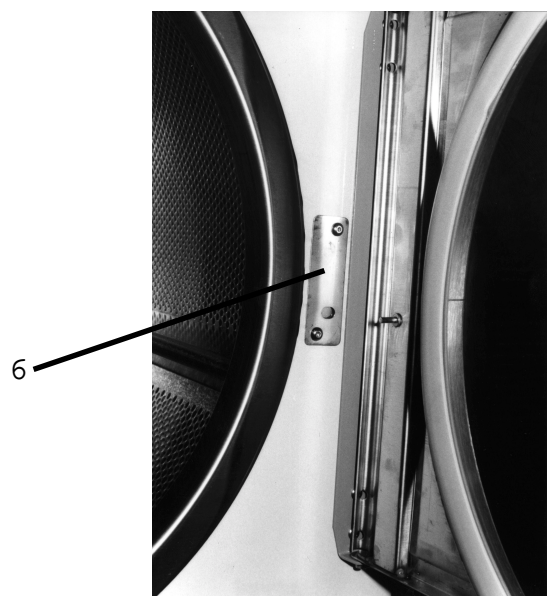
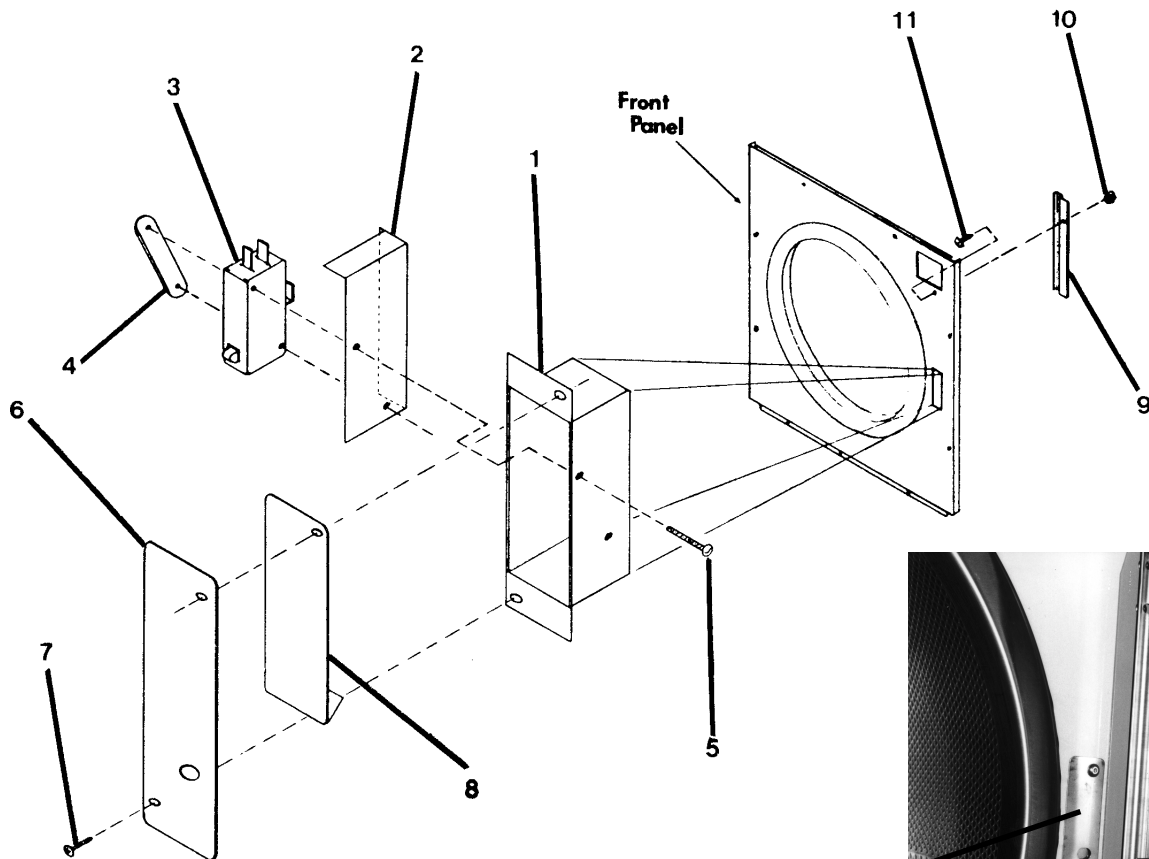



# CONTROL BOX GROUP

Key	Part Number	Description	
1	9041-081-001	Box , Control	1
*	9074-280-001	Cover, Control Box	1
*	9545-008-024	Screw	4
2	5192-295-001	Relay	1
*	9545-045-007	Screw, #8ABx 3/8	2
3	9897-035-002	Terminal Block Assembly, Power	1
4	9558-029-003	Strip , Terminal Marker	1
*	9545-045-007	Screw, #8ABx 3/8	2
5	9897-034-001	Terminal Block Assembly	1
6	9558-027-001	Strip , Terminal Marker	1
7	8652-134-001	Terminal Lug	1
8	8639-621-007	Screw, Hx #10-32 x 1/2	1
*	8641-582-006	Lockwasher, Ex Tooth # 10	1
9	8711-007-001	Transformer, Control	1
*	9545-012-009	Screw , Hx. #10ABx3/8	2

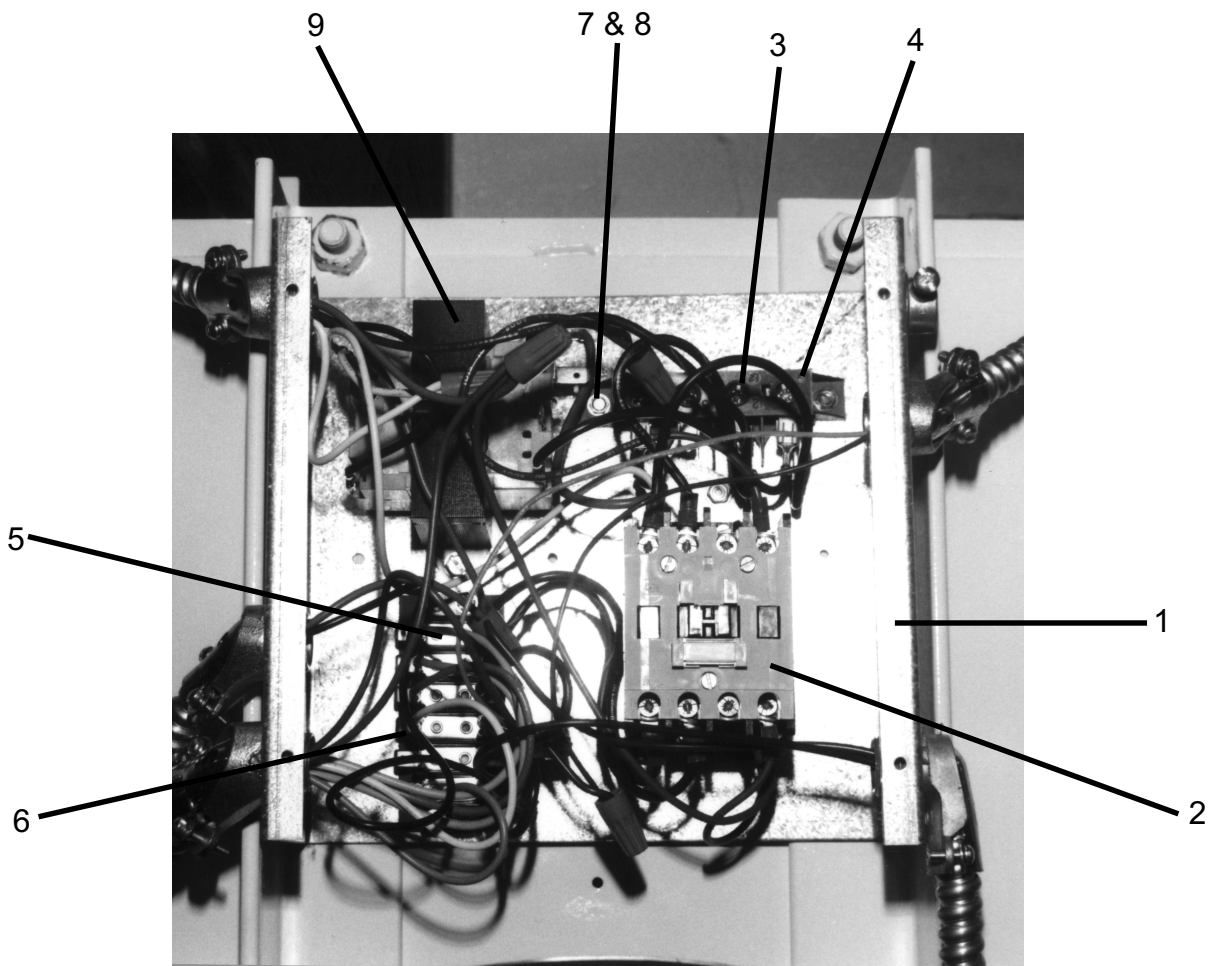

# BEARING HOUSING GROUP

Key	Part Number	Description	
*	9803-189-001	Housing, Bearing Ass'y w one( rear ) bearing .....	1
1	9241-183-003	Housing, Bearing .....	1
2	9036-159-001	Bearing, Ball-Rear .....	1
*	9036-159-002	Bearing, Ball-Front .....	1
3	8641-581-026	Washer, Flat 1/2" .....	4
4	8641-582-004	Lockwasher spring 1/2" .....	4
5	9545-017-004	Bolt, 1/2-13x1 .....	4
6	9545-059-003	Screw, 7/16-14x1 1/2 .....	2
*	8641-582-013	Lockwasher, 7/16 .....	2
7	8640-416-001	Nut, 7/16-14. ....	4
*	9487-234-001	Ring, Tolerance .....	1

\* Not Illustrated

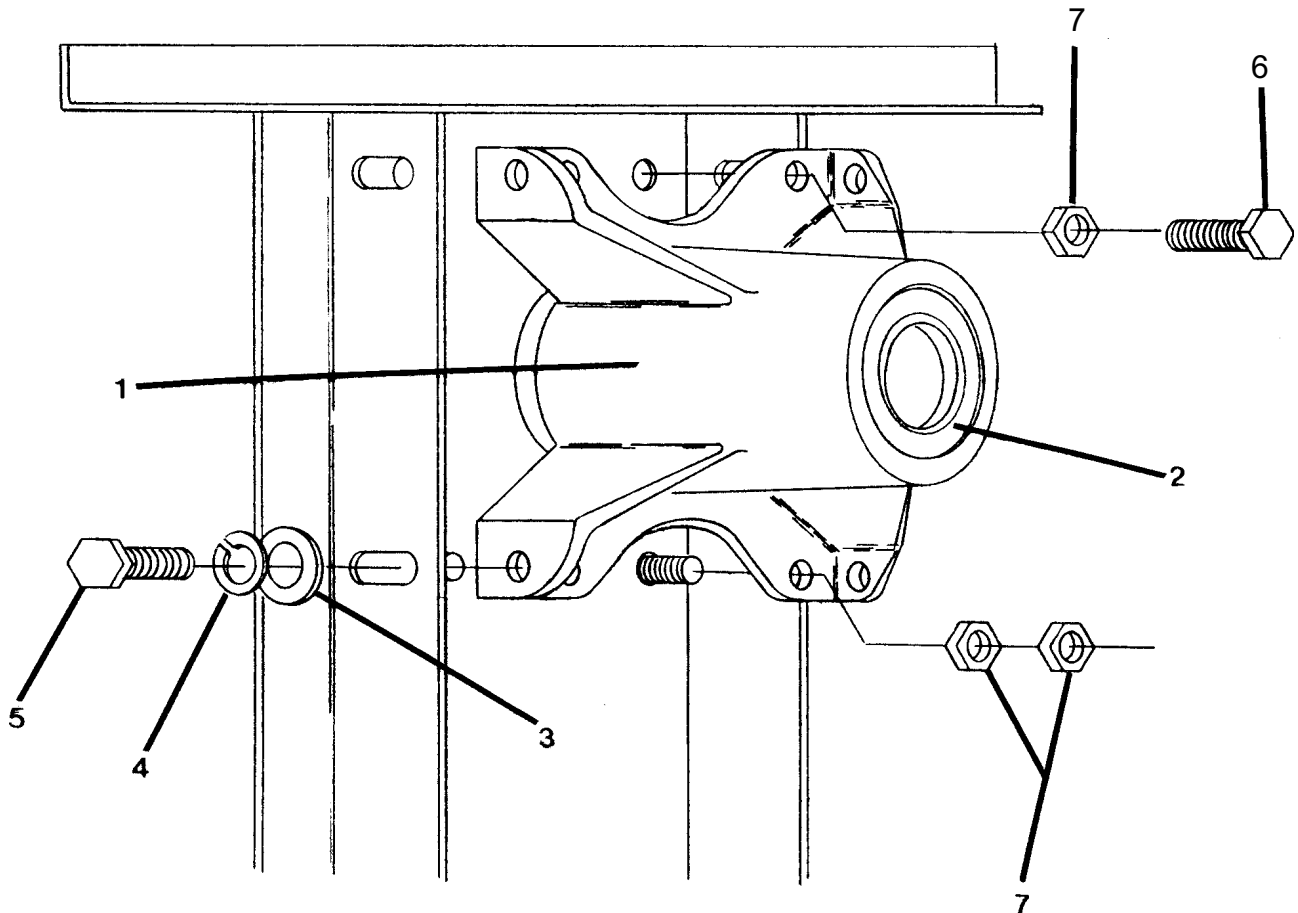

# TUMBLER GROUP

Key	Part Number	Description	
1	9848-118-001	Tumbler Ass'y .....	1
2	9873-005-001	Spider Ass'y with bearing on .....	1
3	9497-226-001	Rod, Tumbler .....	4
4	8640-417-002	Nut 1/2"-13 .....	4
5	9552-013-000	Shim .....	4
6	8641-582-004	Washer, Spring Lock .....	4
7	8641-587-001	Washer, Tumbler Rod Special .....	4
*	9487-234-001	Ring, Tolerance .....	1
8	8641-582-016	Lock Washer ext tooth 1/2", Tumbler Shaft .....	1
9	8641-581-026	Flat Washer 1/2", Tumbler Shaft .....	1
10	9545-017-009	Screw, Tumbler Shaft 1/2-13 x 11/4" .....	1

\* Not Illustrated

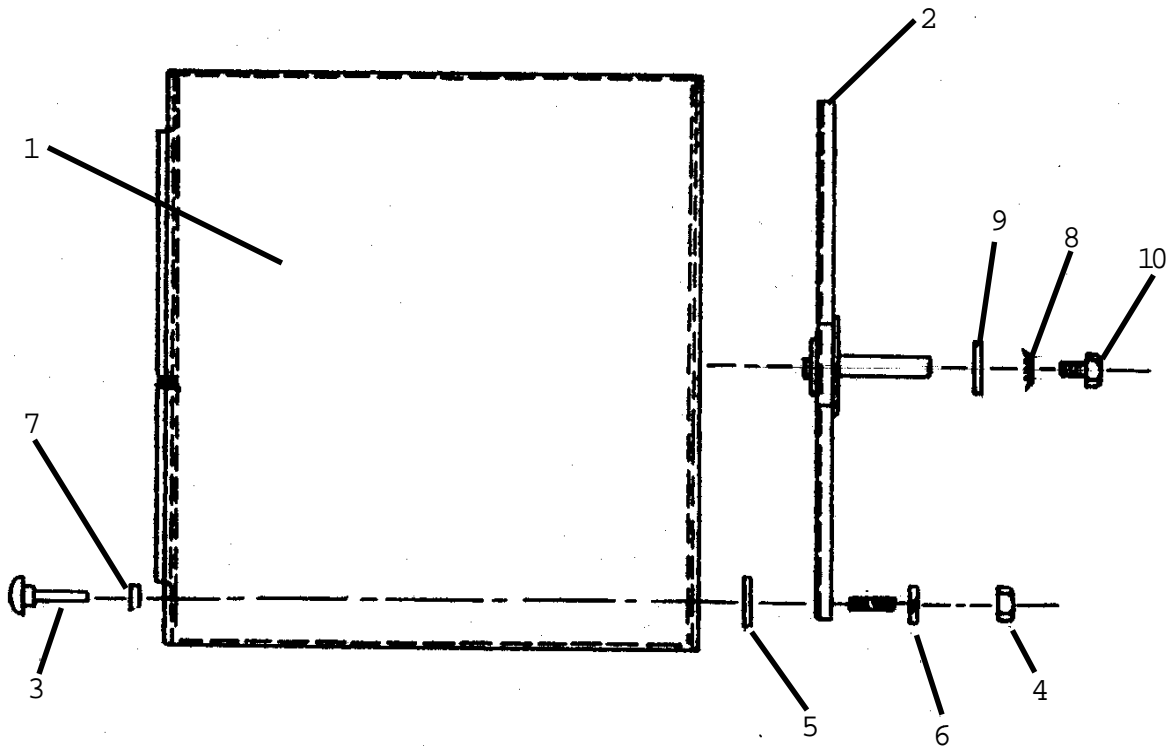

## BURNER HOUSING GROUP

Key	Part Number	Description	
1	9803-190-001	Housing Assembly, Burner .....	1
*	9545-008-024	Screw .....	4
*	9548-280-001	Support, Front Burner Support .....	1
*	9545-045-001	Screw 8B x 1 1/4" .....	2
2	9048-018-001	Burner, Main .....	2
*	9545-045-001	Screw 8B x 1/14" .....	4
3	9875-002-002	Electrode, Ignition .....	1
4	9452-645-001	Plate, Electrode Mtg .....	1
*	9545-045-001	Screw, Electrode Mtg 8B x 11/4" .....	2
5	9379-164-002	Valve, Gas Shut Off .....	1
*	9458-020-003	Pipe, Gas Line .....	1
6	9857-134-002	Control Assy, Gas .....	1
7	9381-010-001	Manifold, Assy 3 port .....	1
*	9425-069-013	Orifice, Burner-Natural .....	3
*	9425-069-006	Orifice, Burner-LP .....	3
*	9379-164-002	Union .....	1
8	9576-203-002	Thermostat, Hi-Limit .....	1
*	9538-142-001	Spacer, Hi-Limit .....	2
*	9545-045-007	Screw 8B x 3/4" .....	2
9	9074-234-001	Cover, Hi-Limit Stat .....	1
*	9545-008-024	Screw 10 B x 3/8" .....	1
10	9857-116-002	Control, Ignition .....	1
*	9545-044-002	Screw 6-32 x 1" .....	2
*	8640-411-003	Nut, Hex Keps #6-32 .....	2
11	9897-026-001	Terminal Block Power .....	1
*	9545-031-004	Screw 6 AB x 5/8" .....	2
*	9039-915-001	BRACKET, Pipe .....	1
*	9545-031-004	Screw 6AB x 5/8" .....	2
12	9631-403-003	Wire Ass'y, High Voltage .....	1
*	9627-711-001	Harness, Low Voltage Ignition .....	1
*	9054-045-001	Fuseholder .....	1
*	8636-018-001	Fuse 1.5 amps .....	1
15	8711-007-001	Transformer, Control .....	1
*	9545-008-026	Screw, #10x1/2" .....	2
*	9732-102-006	Kit, LP Conversion .....	1

\* Not Illustrated

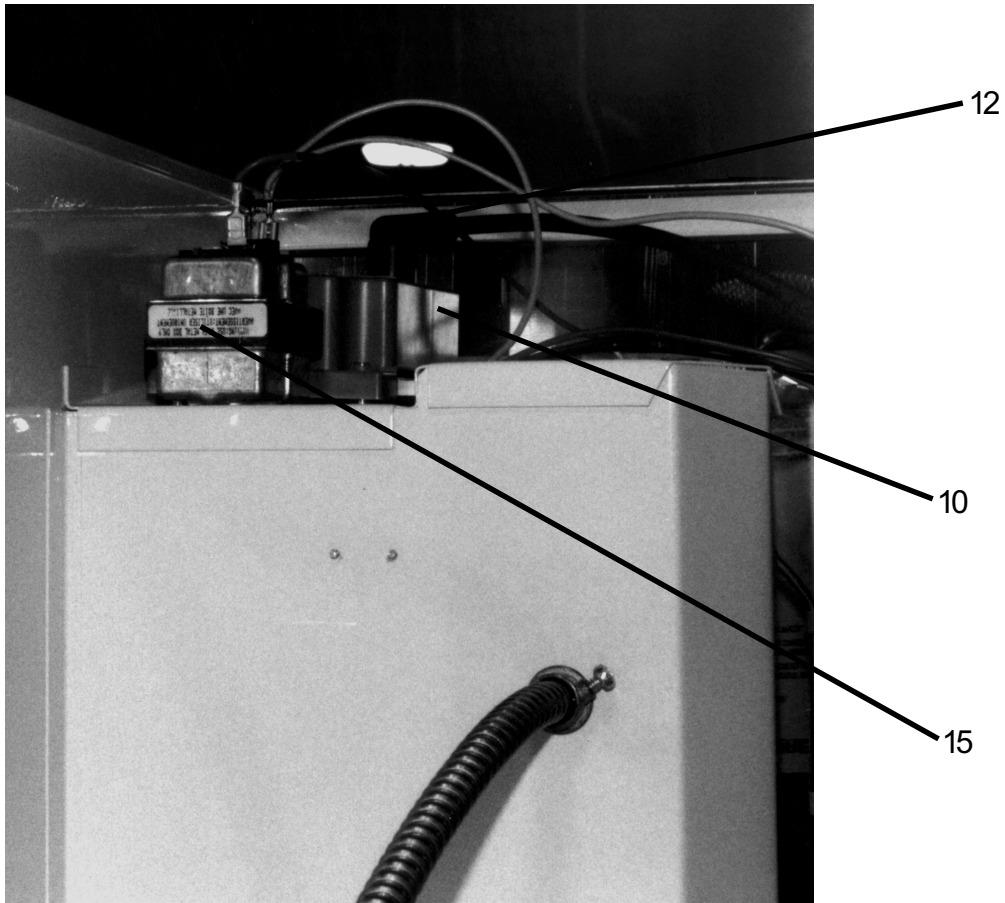
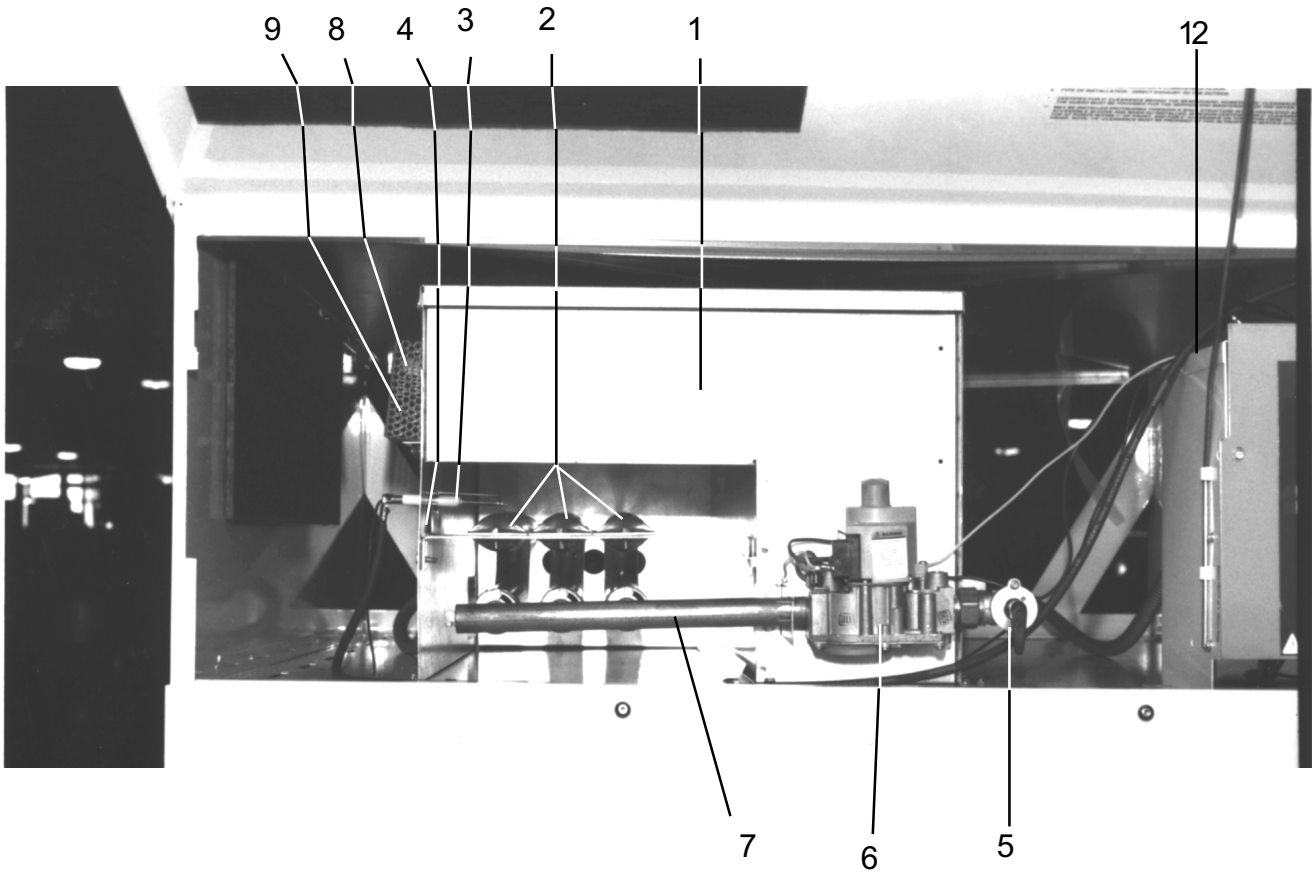

# DAMPER SWITCH, LINT HOOD & BLOWER IMPELLER GROUP STYLE NO. 1

Key	Part Number	Description	
1	9539-432-001	Switch, Damper .....	1
*	9545-044-002	Screw, Hx #6-32x1 .....	1
*	8640-411-003	Nut, Hex #6-32 .....	1
*	9545-044-002	Screw, Hx 6-32x1 .....	2
*	8640-420-001	Nut, Speed Tandem .....	1
2	9125-001-001	Damper .....	1
3	9451-146-001	Pin, Damper Hinge .....	1
4	9074-242-002	Cover, Damper Switch .....	1
*	9209-037-002	Grommet .....	1
5	9834-008-001	Hood Ass'y, Lint .....	1
6	8640-412-004	Nut, Whizlock .....	6
*	9822-031-002	Lint Screen 34" length (newest style ) .....	1
*	9822-031-001	Lint Screen 36" length (old style ) .....	1
7	9576-207-006	Thermostat, Safety .....	1
*	9545-008-001	Screw, Hx. #10x1/4 .....	2
8	9539-487-001	Switch, Lower Door .....	1
9	9029-092-001	Bracket, Lower Door Switch .....	1
*	9545-008-024	Screw , Hx washer #10AB x 3/8" .....	2
*	9545-044-004	Screw, Rd #6-32 x 1/4" .....	2
10	9278-037-003	Impeller, w/set screws .....	1
*	9345-824-002	Schematic Wiring .....	1
*	9345-825-002	Diagram Wiring .....	1

\* Not Illustrated

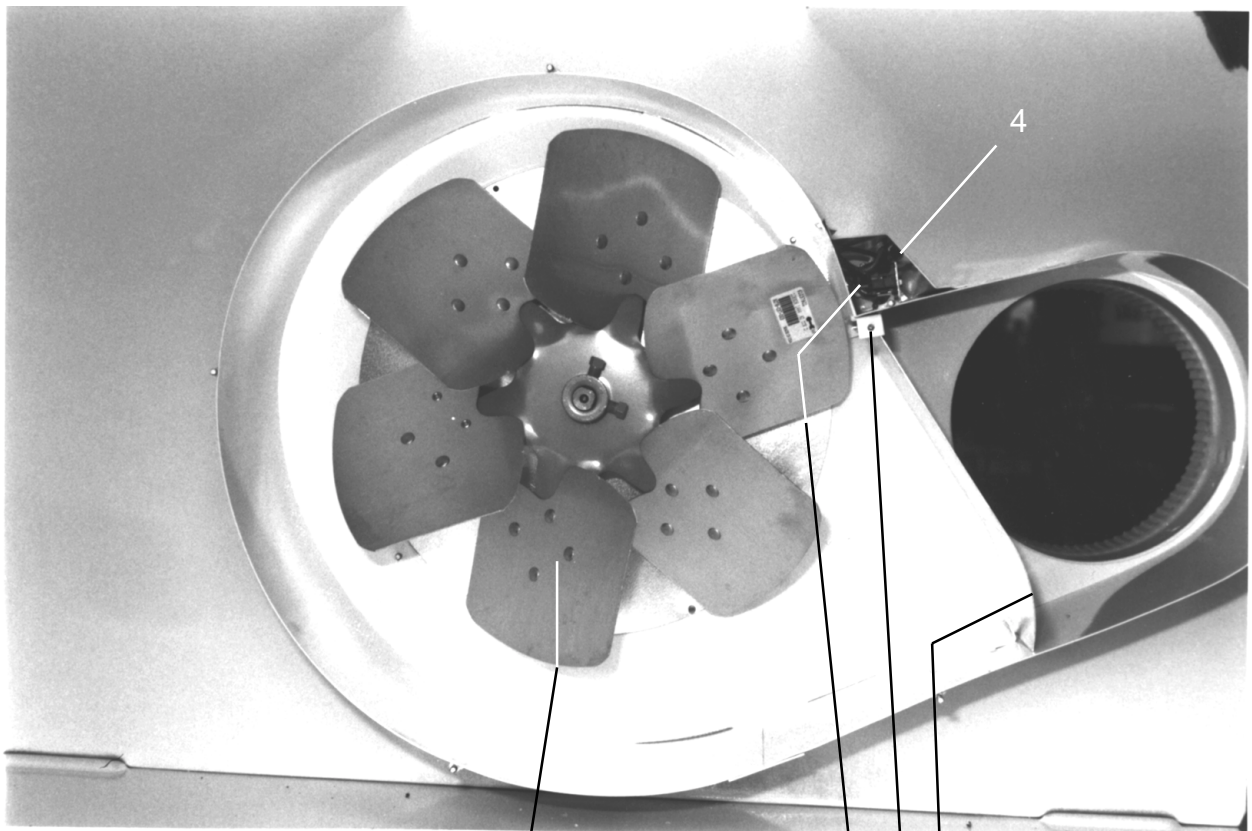

- 4
- 1
- 2
- 10

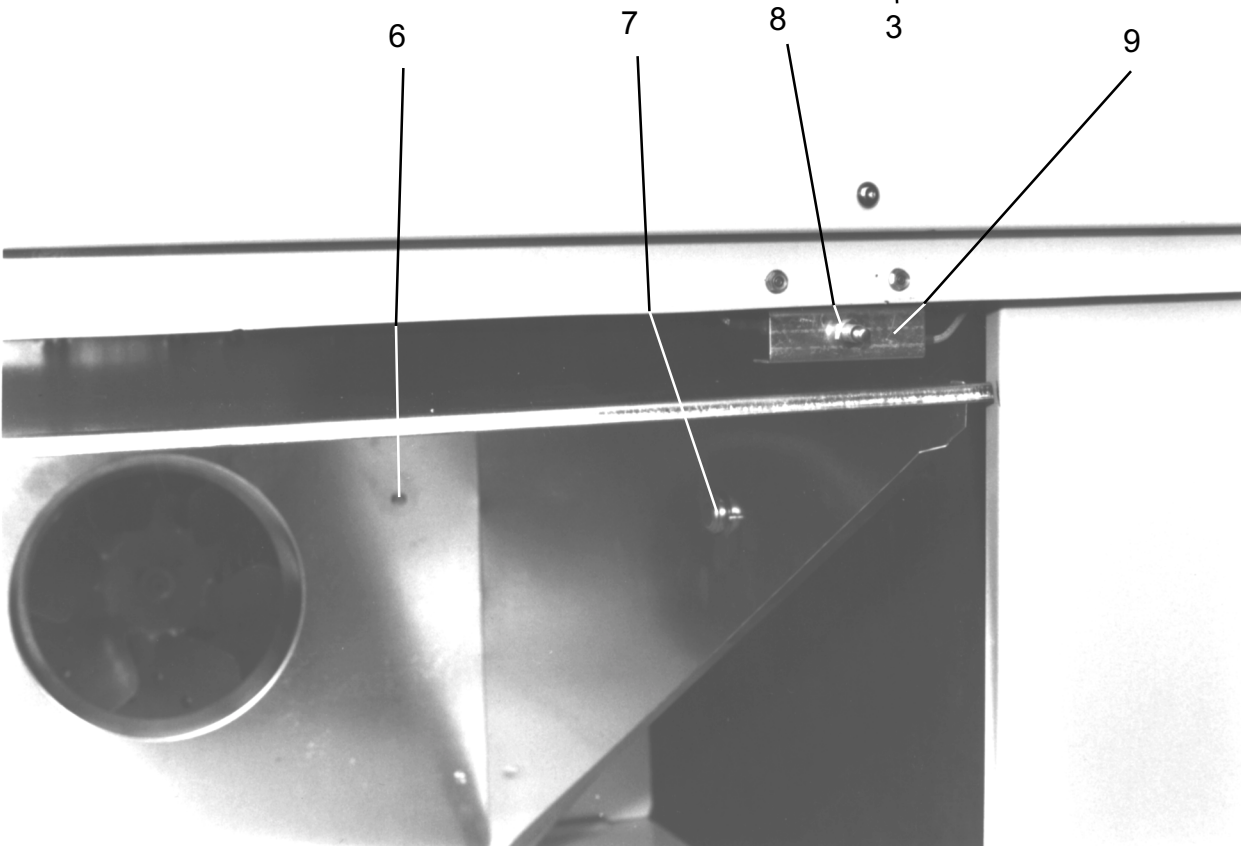

- 6
- 7
- 8
- 3
- 9

## DRIVE GROUP

Key	Part Number	Description	
1	9376-299-002	Motor, Drive .....	1
*	9545-014-004	Screw, Hx 5/16 .....	4
*	8640-400-003	Nut .....	4
2	9453-157-001	Pulley, Motor .....	1
*	9545-028-013	Screw, Set.....	2
3	9991-054-002	Support Ass'y, Motor .....	1
4	9545-029-005	Screw 3/8-16 x 1" .....	4
4	8640-415-004	Nut .....	4
*	9278-037-003	Impeller .....	1
*	9074-275-003	Cover, Impeller Formed .....	1
*	9545-008-001	Screw, Hx #10x1/4 .....	4
5	9991-053-001	Support Assy, Intermed. Pulley .....	1
6	9545-029-010	Bolt, Rd Hd .....	3
7	9545-029-003	Screw .....	1
8	8640-415-004	Nut .....	3
*	8641-581-035	Washer, Flat .....	4
9	9861-024-003	Arm Assy-Tension Complete after serial # 124816 .....	1
9	9861-024-001	Arm Assy-Tension, Complete .....	1
*	8641-581-035	Washer, Flat .....	6
*	9487-200-003	Ring-Retaining .....	2
10	9908-042-006	Pulley Assy, Intermediate after serial number #124816 .....	1
10	9908-042-003	Pulley Assy, Intermediate .....	1
*	9036-159-007	Bearing, Ball-Idler Pulley .....	2
*	9538-173-002	Spacer, Bearing .....	1
11	9908-043-002	Pulley Driven .....	1
*	9487-234-001	Ring, Tolerance .....	1
12	8641-581-026	Washer, Flat .....	1
*	8641-582-016	Lockwasher .....	1
13	9545-017-009	Screw, Hx Cap .....	1
14	9040-077-004	Belt, Final Drive .....	1
15	9040-077-003	Belt, Motor Drive .....	1
16	9534-151-000	Spring, Belt Tension .....	1
17	9099-012-002	Chain, Spring Tension .....	1
18	9248-022-002	Hook, Tension .....	1
*	9208-050-001	Guard, Drive .....	1
*	9454-685-001	Panel, Drive Guard, RH .....	1
*	9454-686-001	Panel, Drive Guard, LH .....	1
*	9550-175-001	Shield, Motor .....	1
*	9545-008-003	Screw .....	2
*	9545-008-024	Screw .....	17

\* Not Illustrated



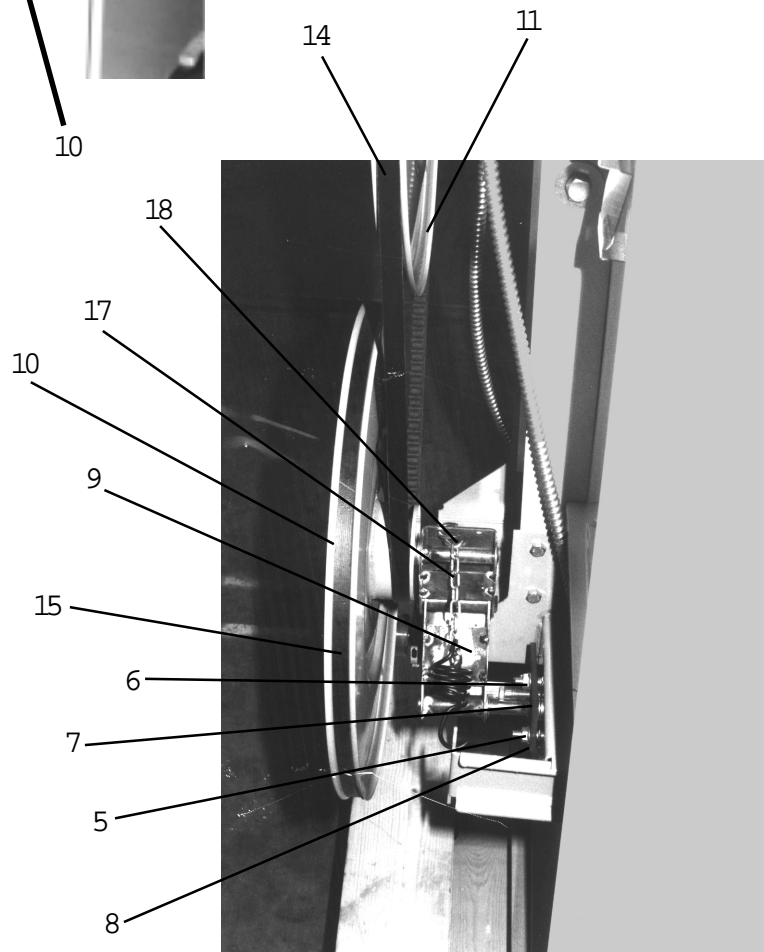
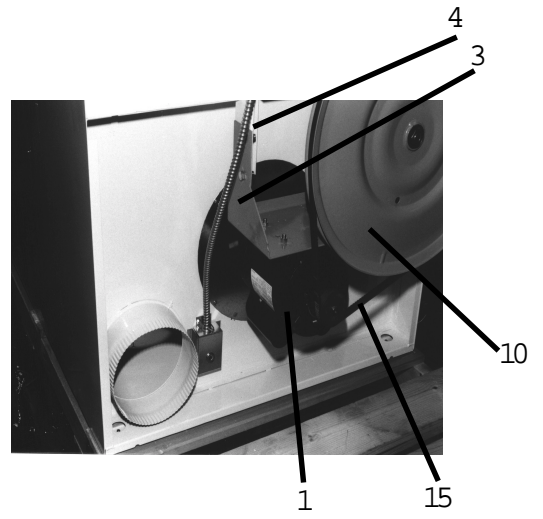
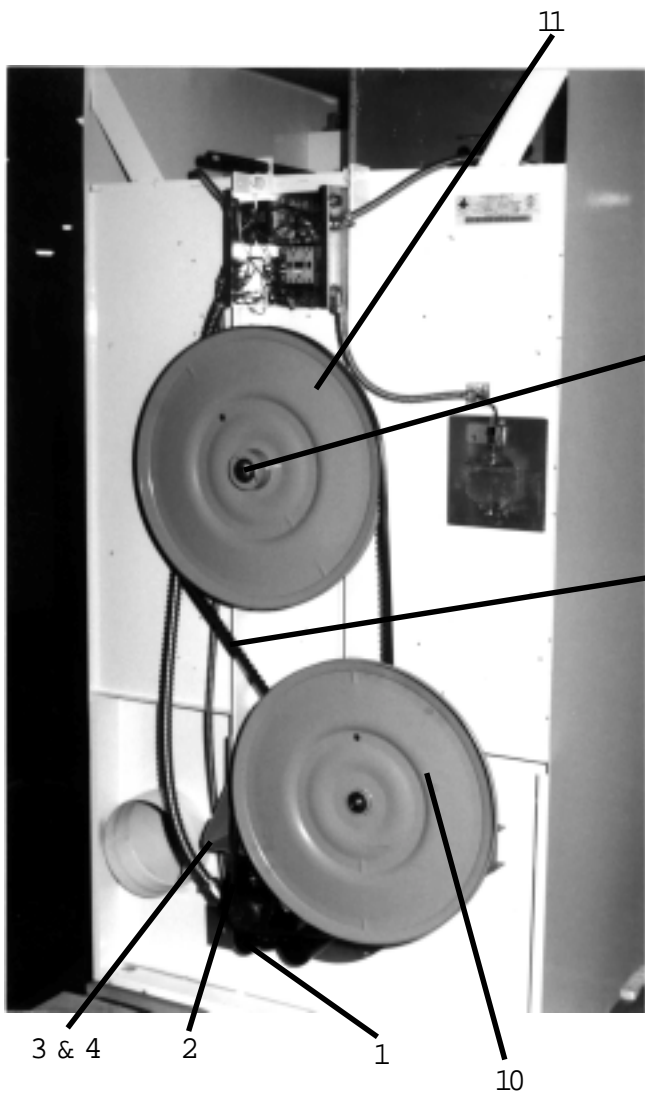

# BLOWER IMPELLER AND AIR FLOW SWITCH GROUP OVER TEMPERATURE SWITCH STYLE NO. 2

KEY	PART NUMBER	DESCRIPTION	QTY.
1	9074-283-001	Cover Plate	1
2	9029-046-001	Actuator Stop	1
3	9029-100-001	Bracket -Switch	1
4	9545-008-001	Screw-10B x 1/4	4
5	9539-461-009	Switch-Micro	1
6	9545-020-001	Screw 4-40 x 5/8	2
7	8640-401-001	Nut Twin	1
8	9008-007-001	Actuator-Switch	1
9	9451-169-002	Pin Cotter	1
10	9039-575-000	Bracket Conduit	1
11	9825-057-002	Over-tempcoverass'y	1
12	9576-207-006	Thermostatover-tempMnl.	1
13	9545-008-001	Screw 10B x 1/4	2
*	9486-137-001	Retainer,pushon	1
*	9535-050-003	Sleeve-Hi-Limitswitcaccess	



13  
12  
11  
10

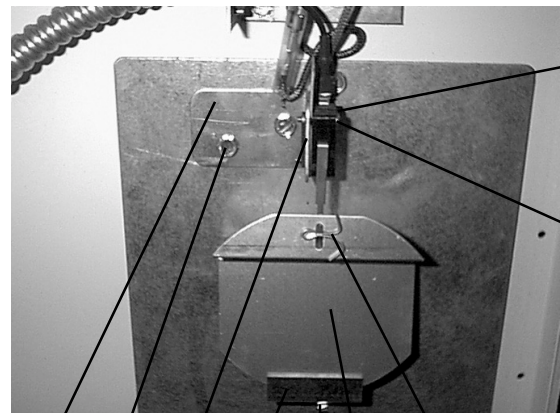

5  
6  
3  
4  
7  
2  
4  
8  
9

# BLOWER IMPELLER & LINT HOOD ASS'Y STYLE NO. 2

KEY	PART NUMBER	DESCRIPTION	QTY.
1	9822-031-002	Lint Screen Ass'y	1
2	9278-038-003	Impeller	1
3	9834-009-001	Hood assembly Lint	1
*	9345-824-008	Schematic 80LB	1
	9345-825-009	Diagram 80lb	1

