



# **AD-95/ML-95 Parts Manual 1996 thru 1999**

---

**American Dryer Corporation**  
88 Currant Road  
Fall River, MA 02720-4781  
Telephone: (508) 678-9000 / Fax: (508) 678-9447  
E-mail: [techsupport@amdry.com](mailto:techsupport@amdry.com)

# Retain This Manual In A Safe Place For Future Reference

**American Dryer Corporation** products embody advanced concepts in engineering, design, and safety. If this product is properly maintained, it will provide many years of safe, efficient, and trouble-free operation.

*ONLY qualified technicians should service this equipment.*

**OBSERVE ALL SAFETY PRECAUTIONS** displayed on the equipment or specified in the installation/operator's manual included with the dryer.

The following “**FOR YOUR SAFETY**” caution **must be** posted near the dryer in a prominent location.

**FOR YOUR SAFETY**

Do not store or use gasoline or other flammable vapors or liquids in the vicinity of this or any other appliance.

**POUR VOTRE SÉCURITÉ**

Ne pas entreposer ni utiliser d'essence ni d'autres vapeurs ou liquides inflammables dans le voisinage de cet appareil ou de tout autre appareil.

We have tried to make this manual as complete as possible and hope you will find it useful. **ADC** reserves the right to make changes from time to time, without notice or obligation, in prices, specifications, colors, and material, and to change or discontinue models.

## Important

For your convenience, log the following information:

**DATE OF PURCHASE** \_\_\_\_\_ **MODEL NO.** \_\_\_\_\_

**DISTRIBUTORS NAME** \_\_\_\_\_

**Serial Number(s)** \_\_\_\_\_

\_\_\_\_\_

\_\_\_\_\_

Replacement parts can be obtained from your distributor or the **ADC** factory. When ordering replacement parts from the factory, you can FAX your order to **ADC** at (508) 678-9447 or telephone your orders directly to the **ADC** Parts Department at (508) 678-9000. Please specify the dryer **model number** and **serial number** in addition to the **description** and **part number**, so that your order is processed accurately and promptly.

The illustrations on the following pages may not depict your particular dryer exactly. The illustrations are a composite of the various dryer models. Be sure to check the descriptions of the parts thoroughly before ordering.

**“IMPORTANT NOTE TO PURCHASER”**

Information must be obtained from your local gas supplier on the instructions to be followed if the user smells gas. These instructions must be posted in a prominent location near the dryer.

# Table of Contents

Control Door Assembly .....	2
Phase 6 Microprocessor Panel Assembly <b>for models mfd. as of February 11, 1998</b> .....	3
Phase 6 Microprocessor Panel Assembly <b>for models mfd. prior to February 11, 1998</b> .....	4
Sensor Bracket Assembly .....	5
Front Panel/Main Door Assembly <b>for models mfd. as of October 24, 1997</b> .....	6, 7
Front Panel/Main Door Assembly <b>for models mfd. prior to October 24, 1997</b> .....	8, 9
Main Door Switch <b>for models mfd. as of October 24, 1997</b> .....	10
Main Door Switch <b>for models mfd. prior to October 24, 1997</b> .....	11
Lint Door Assembly .....	12, 13
Basket (Tumbler) Assembly .....	14
Front Thruster Wheel Assembly <b>for models mfd. as of September 15, 1997</b> .....	15
Front Thruster Wheel Assembly <b>for models mfd. prior to September 15, 1997</b> .....	16
Rear Thruster Wheel Assembly <b>for models mfd. as of September 15, 1997</b> .....	17
Rear Thruster Wheel Assembly <b>for models mfd. prior to September 15, 1997</b> .....	18
Front Thruster Wheel Assembly <b>for models mfd. as of April 6, 1998</b> .....	19
Rear Thruster Wheel Assembly <b>for models mfd. as of April 6, 1998</b> .....	20
Idler Shaft Assembly <b>for models mfd. as of December 15, 1997</b> .....	21
Idler Shaft Assembly <b>for models mfd. prior to December 15, 1997</b> .....	22
Drive Shaft Assembly <b>for models mfd. as of December 15, 1997</b> .....	23
Drive Shaft Assembly <b>for models mfd. prior to December 15, 1997</b> .....	24
Drive Motor Assembly .....	25
Blower (Fan/Impellor) Motor Assembly .....	26
Sail Switch Assembly .....	27
Blower (Fan/Impellor) Wheel Assembly <b>for models mfd. as of July 1, 1998</b> .....	28, 29
Blower (Fan/Impellor) Wheel Assembly <b>for models mfd. prior to July 1, 1998</b> .....	30, 31
Burner Assembly .....	32, 33
Reversing Relay Assembly <b>for 208 Volt - 230/240/380/416 Volt and Models ONLY</b> .....	34, 35
Reversing Relay Assembly <b>for 460/480 Volt Models ONLY</b> .....	36
Transition Piece Assembly With Damper <b>for models mfd. as of September 12, 1997</b> .....	37
Exhaust Adapter Assembly <b>for models mfd. prior to September 12, 1997</b> .....	38
Pneumatic Valve Assembly .....	39

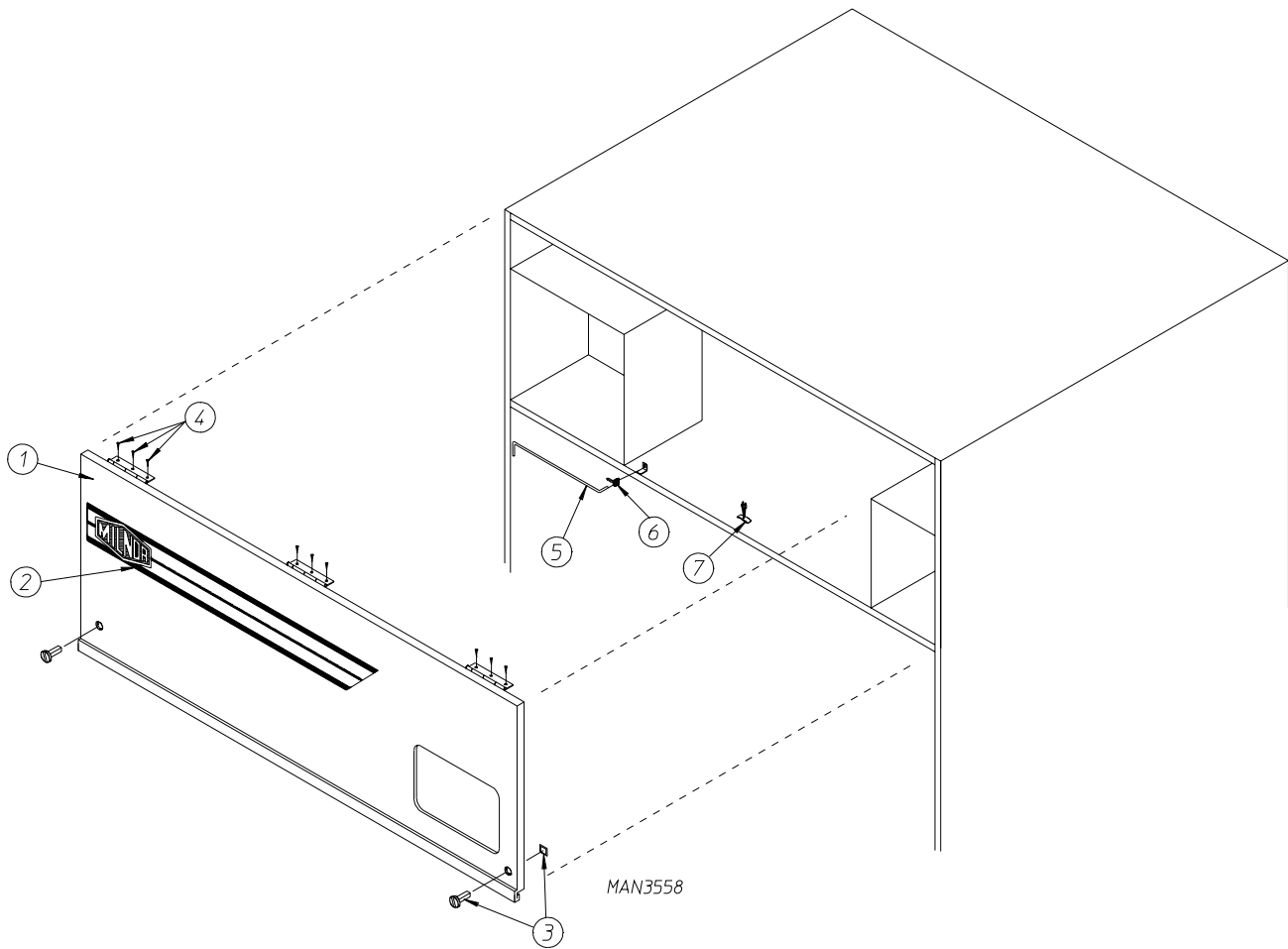

<u>Illus. No.</u>	<u>Part No.</u>	<u>Qty.</u>	<u>Description</u>
1	882093	1	White Control Door Assembly (As of February 11, 1998)
	882092	1	Blue Control Door Assembly (As of February 11, 1998)
	881732	1	White Control Door Assembly ONLY (Prior to February 11, 1998)
	881731	1	Blue Control Door Assembly ONLY (Prior to February 11, 1998)
2	112368	1	Milnor Logo ONLY
3	160005	2	Spring Turn Latch (2-piece)
4	150309	9	#10-16 x 1/2" Hex Head TEK Crimptite Screw
5	102505	1	Control Door Support Rod
6	102601	1	Control Door Retainer Clip
7	102600	1	Control Door Rod Catch

As of February 11, 1998

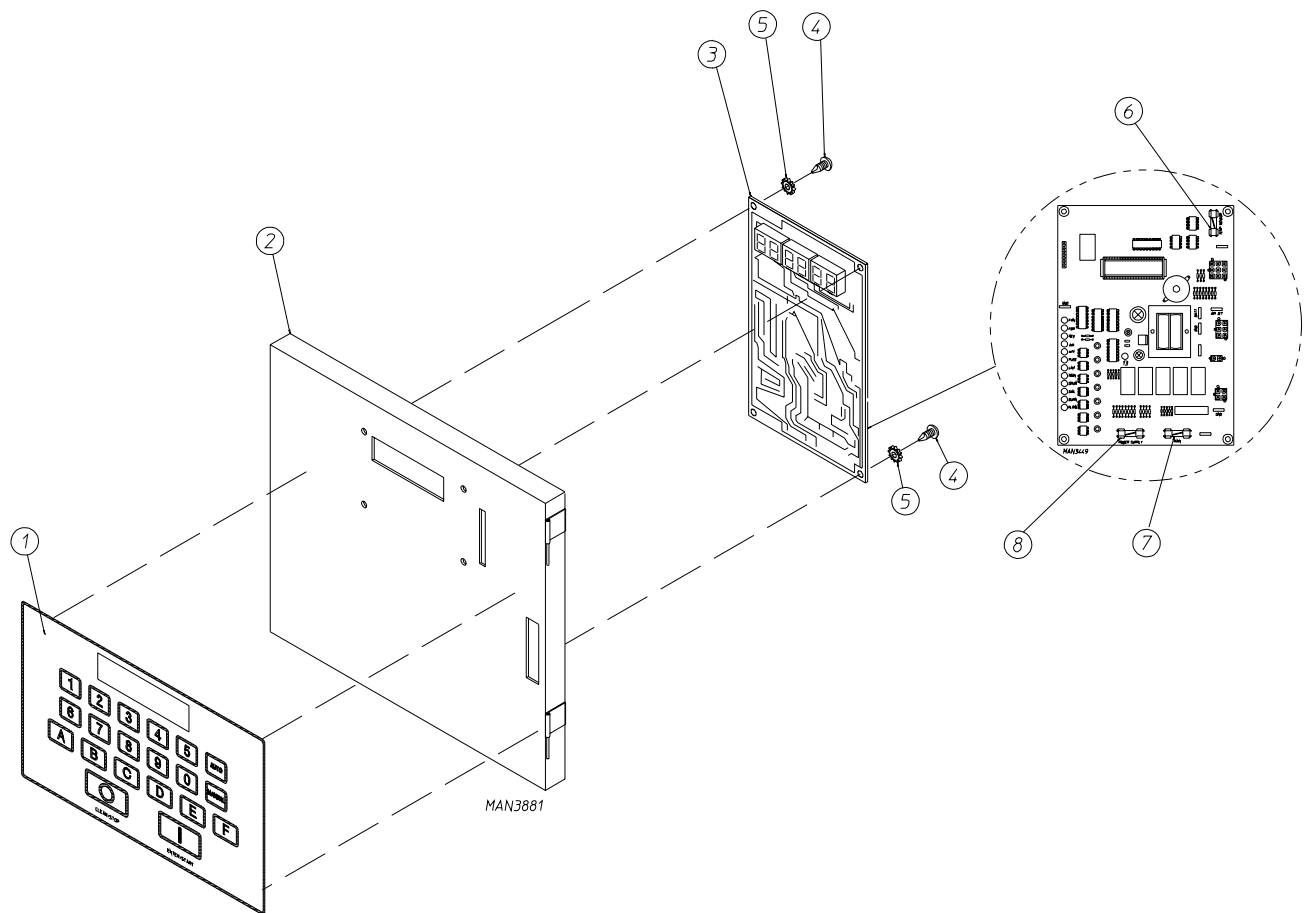

<u>Illus. No.</u>	<u>Part No.</u>	<u>Qty.</u>	<u>Description</u>
1	112537	1	Phase 6 OPL Keypad
	112276	1	OPL Stick-on Labels (English Only) Not Illustrated
	112275	1	OPL Stick-on Labels (Spanish, Italian, and Hebrew) Not Illustrated
	112277	1	3 Language OPL Stick-on Labels (English, Spanish, and Hebrew) Not Illustrated
	112278	1	5 Language OPL Stick-on Labels (Italian, Dutch, French, German, and Chinese) Not Illustrated
2	824480	1	Phase 6 Microprocessor (computer) Panel Only
3	137124	1	Phase 6 reversing Microprocessor Controller (computer) with Air Jet (As of June 26, 1998)
	137122	1	Phase 6 Reversing Microprocessor Controller (computer) without Air Jet (Prior to June 26, 1998)
4	150005	6	#6-32 x 3/4" Phillips Round Head Machine Screw
5	153010	6	#6 Star Washer
6	136048	1	1/8-Amp (Slo Blo) Fuse
7	136017	1	3.5-Amp (Fast Acting) Fuse
8	136019	1	1-Amp (Fast Acting) Fuse

Prior to February 11, 1998

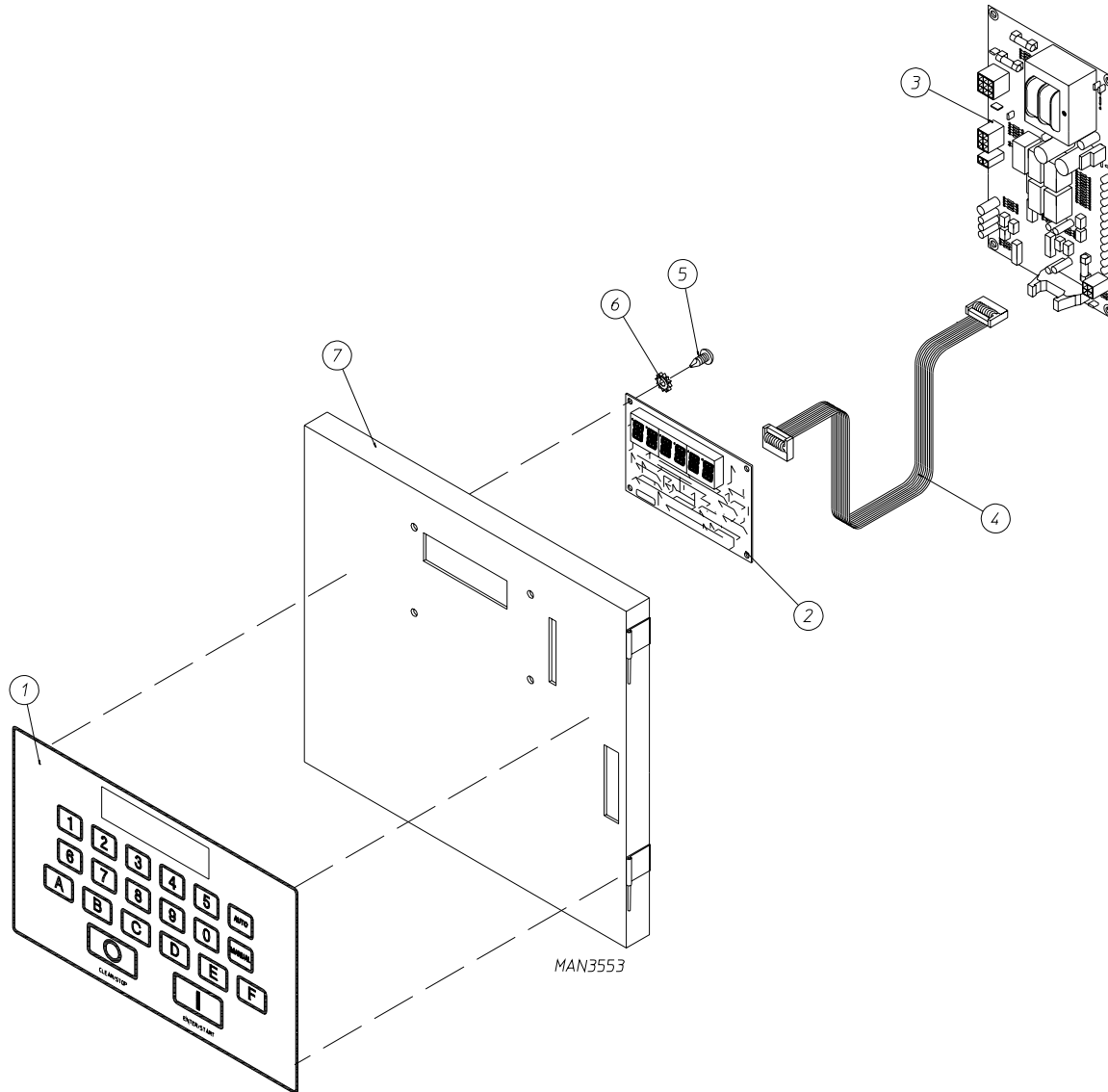

<u>Illus. No.</u>	<u>Part No.</u>	<u>Qty.</u>	<u>Description</u>
1	112537	1	Phase 6 OPL Keypad
	112276	1	OPL Stick-on Labels (English Only) Not Illustrated
	112275	1	OPL Stick-on Labels (Spanish, Italian and Hebrew) Not Illustrated
	112277	1	3 Language OPL Stick-on Labels (English, Spanish and Hebrew) Not Illustrated
	112278	1	5 Language OPL Stick-on Labels (Italian, Dutch, French, German and Chinese) Not Illustrated
2	137116	1	Phase 6 Microprocessor Controller (computer)
3	137118	1	Phase 6 OPL I/O (Input/Output) Board, Reversing
4	137121	1	12" Ribbon Cable Assembly
5	150005	6	#6-32 x 3/4" Phillips Round Head Machine Screw
6	153010	6	#6 Star Washer
7	881730	1	Microprocessor (computer) Panel Only

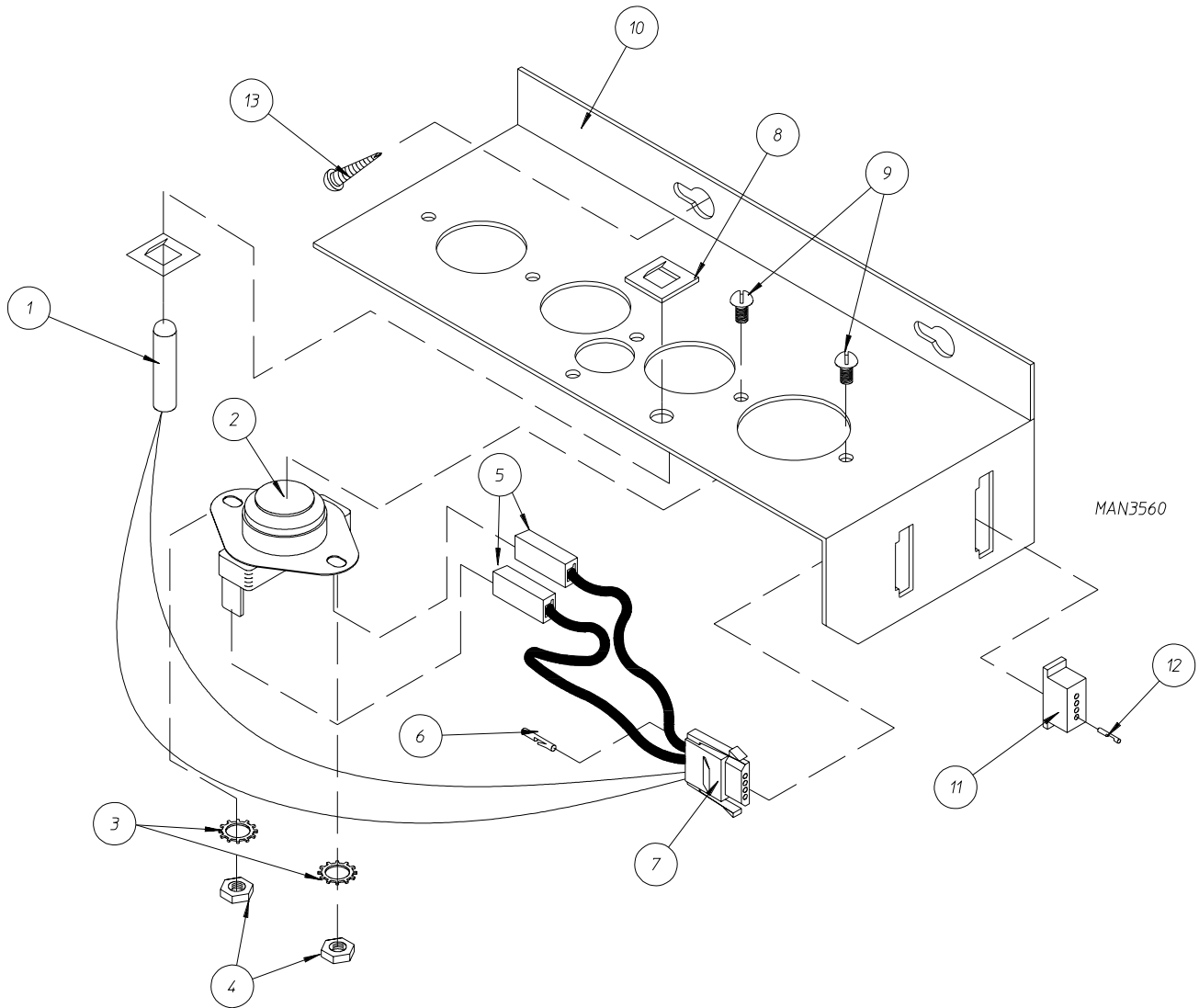

<u>Illus. No.</u>	<u>Part No.</u>	<u>Qty.</u>	<u>Description</u>
1	880251	1	1/4" Temperature Sensor Probe Assembly Complete (includes illus. nos. 1 and 5 through 8)
2	130103	1	225° Large Automatic Thermostat ONLY
3	153010	2	#6 Star Washer
4	152000	2	#6-32 Hex Nut
5	121028	2	Insulated Terminal ONLY
6	122701	4	Socket Terminal ONLY
7	122605	1	4-Pin Socket Connector ONLY
8	154007	2	1/4" Tinnerman Push-on Fastener
9	150005	2	#6-32 x 1/4" Phillips Round Head Machine Screw
10	881710	1	Sensor Mounting Bracket Assembly Complete (includes illus. nos. 1 through 10)
	390121	1	Universal Sensor Bracket ONLY
11	122604	1	4-Pin Connector ONLY
12	122700	4	Pin Terminal ONLY
13	150301	2	#8-18 x 7/16" Phillips Pan Head TEK Screw

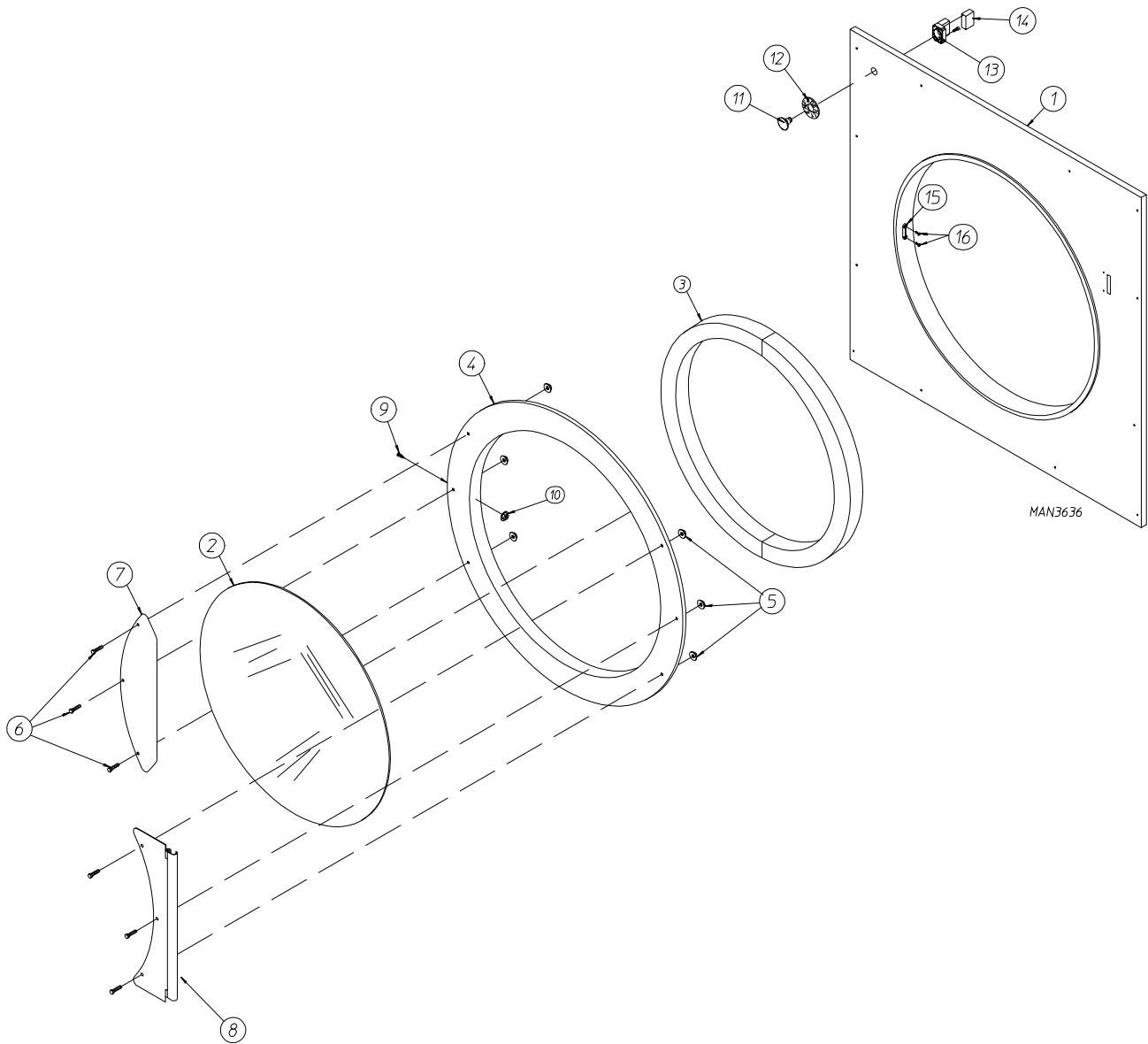



As of October 24, 1997

<u>Illus. No.</u>	<u>Part No.</u>	<u>Qty.</u>	<u>Description</u>
1	881804	1	White Front Panel Assembly (includes illus. nos. 1, 15 and 16) For models mfd. as of December 3, 1997
	881696	1	White Front Panel Assembly (includes illus. nos. 1, 15 and 16) For models mfd. prior to December 3, 1997
	881805	1	Blue Front Panel Assembly (includes illus. nos. 1, 15 and 16) For models mfd. as of December 3, 1997
	881762	1	Blue Front Panel Assembly (includes illus. nos. 1, 15 and 16) For models mfd. prior to December 3, 1997
2	102213	1	29-7/8" Door Glass
	170730	1	Door Glass Adhesive (10.3 oz. cartridge)
3	102354	2	Main Door Gasket (7/8" x 7/8" x 73")
4	881689	1	White Main Door Assembly Complete (includes illus. nos. 2 through 10)
	881761	1	Blue Main Door Assembly Complete (includes illus. nos. 2 through 10)
	881684	1	White Main Door Ring
	881756	1	Blue Main Door Ring
	881806	6	1/4-20 Free Spin Wash Nut (White)
5	881807	6	1/4-20 Free Spin Wash Nut (Blue)
	881740	6	1/4-20 x 5/8" (White) Carriage Bolt
6	881739	6	1/4-20 x 5/8" (Blue) Carriage Bolt
	881688	1	White Main Door Handle
7	881737	1	Blue Main Door Handle
	881685	1	White Main Door Hinge
8	881757	1	Blue Main Door Hinge
	150120	1	Main Door Latch Screw (#10-32 Dome Hex Head Screw)
9	151010	1	#10-32 Acorn Nut
10	122351	1	"EMERGENCY STOP" Push-Pull Button
11	122419	1	"EMERGENCY STOP" Nameplate
12	132387	1	Normally Closed (N.C.) Contact Block
13	132395	1	Normally Closed (N.C.) Contact Block with Base
14	170330	1	Friction Door Latch
15	154215	2	5/32" Pop Rivet

Prior to October 24, 1997

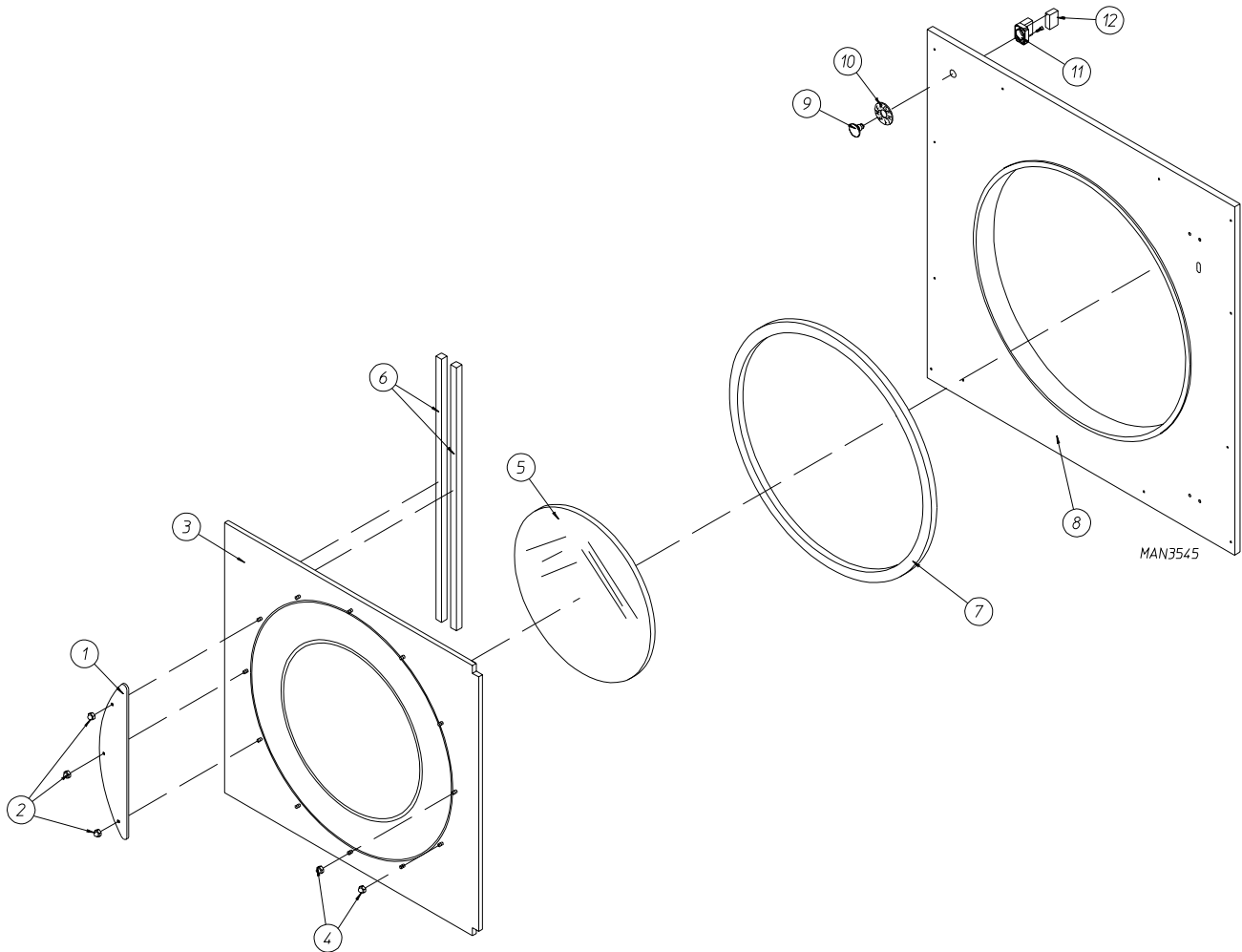

**Prior to October 24, 1997**

<u>Illus. No.</u>	<u>Part No.</u>	<u>Qty.</u>	<u>Description</u>
1	881741	1	White Main Door Handle
	881760	1	Blue Main Door Handle
2	151011	3	5/16-18 Acorn Nut
3	881817	1	White Front Panel/Main Door Assembly with "EMERGENCY STOP" Button (includes illus. nos. 1 through 12)
	881822	1	Blue Front Panel/Main Door Assembly with "EMERGENCY STOP" Button (includes illus. nos. 1 through 12)
	881815	1	White Front Panel/Main Door Assembly without "EMERGENCY STOP" Button (includes illus. nos. 1 through 8)
	881819	1	Blue Front Panel/Main Door Assembly without "EMERGENCY STOP" Button (includes illus. nos. 1 through 8)
4	151011	9	5/16-18 Acorn Nut
5	102210	1	20-7/16" Door Glass
	170730	1	Door Glass Adhesive (10.3 oz. cartridge)
6	102112	2	Door Magnet (5/16" x 1/4" x 34-3/4")
7	102356	1	Main Door Gasket (13-1/6" x 1-3/8" x 97-1/2")
8	881729	1	White Front Panel ONLY for "EMERGENCY STOP"
	881824	1	Blue Front Panel ONLY for "EMERGENCY STOP"
	881728	1	White Front Panel ONLY
	881821	1	Blue Front Panel ONLY
9	122351	1	"EMERGENCY STOP" Push-Pull Button
10	122419	1	"EMERGENCY STOP" Nameplate
11	132387	1	Normally Closed (N.C.) Contact Block
12	132395	1	Normally Closed (N.C.) Contact Block with Base

As of October 24, 1997

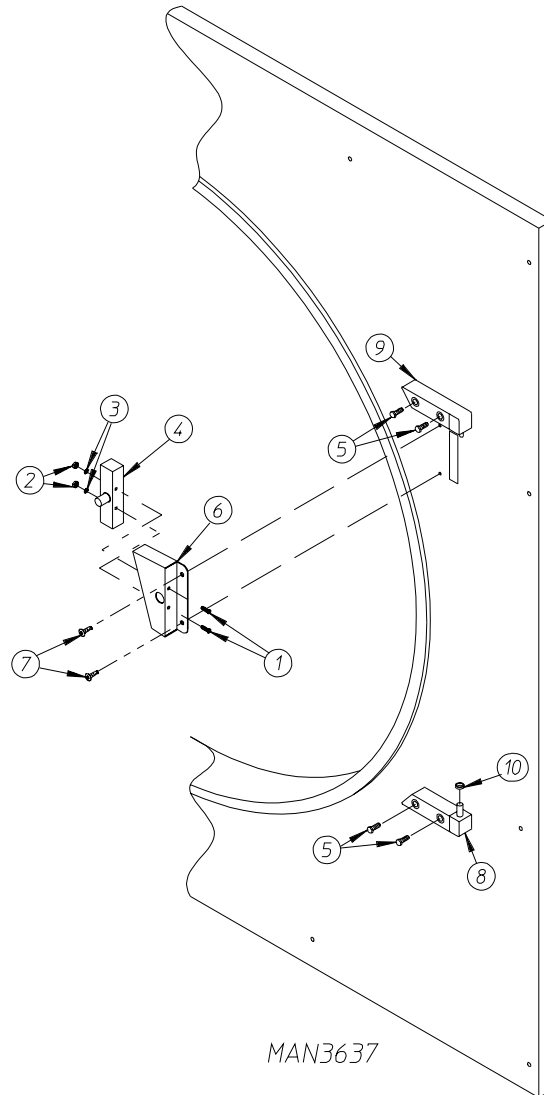

<u>Illus. No.</u>	<u>Part No.</u>	<u>Qty.</u>	<u>Description</u>
1	150006	2	#6-32 x 7/8" Phillips Pan Head Machine Screw
2	152013	2	#6-32 Hex Nut
3	153010	2	#6 Star Washer
4	137005	1	Single Pole Door Switch
5	150443	4	1/4-20 x 3/4" Stainless Steel Cap Screw
6	881687	1	White Main Door Switch Housing ONLY
	881695	1	Blue Main Door Switch Housing ONLY
	881702	1	White Main Door Switch with Housing Assembly (includes illus. nos. 1 through 4 and 6)
	881700	1	Blue Main Door Switch with Housing Assembly (includes illus. nos. 1 through 4 and 6)
7	150443	2	1/4-20 x 3/4" Stainless Steel Cap Screw
8	881441	1	White Bottom Hinge Block
	881735	1	Blue Bottom Hinge Block
9	881440	1	White Top Hinge Block
	881736	1	Blue Top Hinge Block
10	153031	1	Nylon Washer

Prior to October 24, 1997

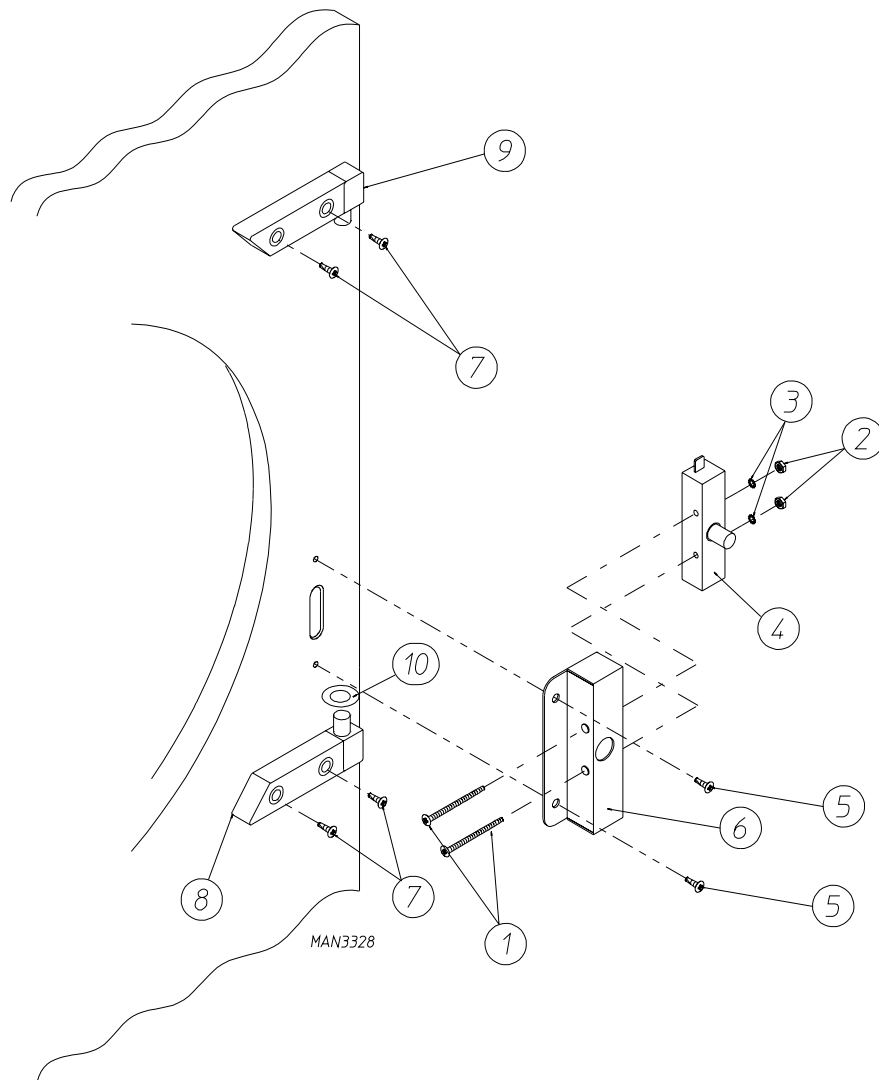

<u>Illus. No.</u>	<u>Part No.</u>	<u>Qty.</u>	<u>Description</u>
1	150006	2	#6-32 x 7/8" Phillips Pan Head Machine Screw
2	152013	2	#6-32 Hex Nut
3	153010	2	#6 Star Washer
4	137005	1	Single Pole Door Switch
5	150443	4	1/4-20 x 3/4" Stainless Steel Cap Screw
6	881726	1	White Main Door Switch Housing ONLY
	881727	1	Blue Main Door Switch Housing ONLY
	881698	1	White Main Door Switch with Housing Assembly (includes illus. nos. 1 through 4 and 6)
	881699	1	Blue Main Door Switch with Housing Assembly (includes illus. nos. 1 through 4 and 6)
7	150443	2	1/4-20 x 3/4" Stainless Steel Cap Screw
8	881441	1	White Bottom Hinge Block
	881735	1	Blue Bottom Hinge Block
9	881440	1	White Top Hinge Block
	881736	1	Blue Top Hinge Block
10	153031	1	Nylon Washer

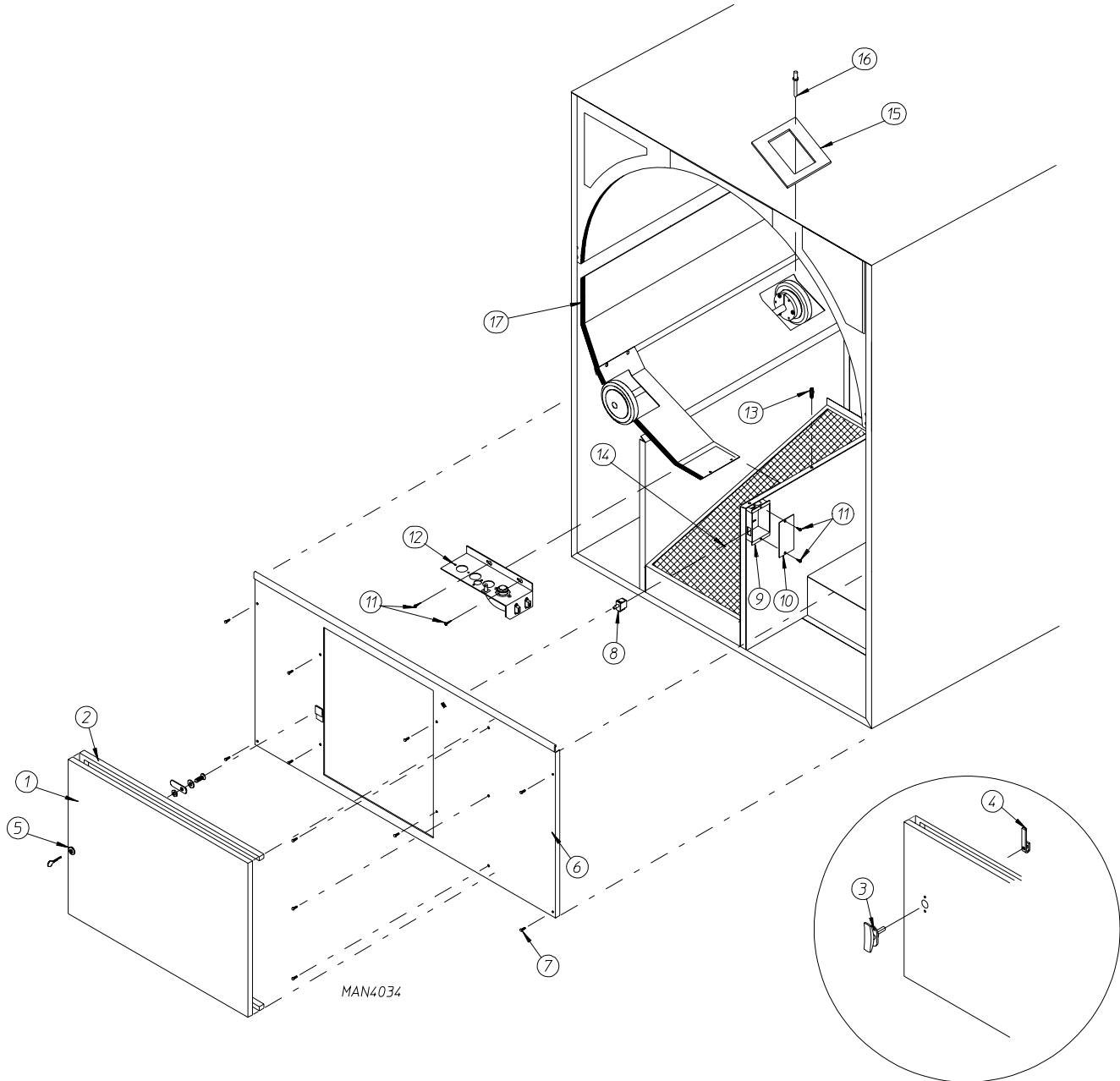

<u>Illus. No.</u>	<u>Part No.</u>	<u>Qty.</u>	<u>Description</u>
1	882115	1	White Lint Door Assembly ONLY (includes illus. nos. 1 and 2)
	881724	1	White Lint Door and Panel Assembly for models with Knob Latch (includes illus. nos. 1, 2 and 6)
	882114	1	Blue Lint Door Assembly ONLY (includes illus. nos. 1 and 2)
	881811	1	Blue Lint Door and Panel Assembly for models with Knob Latch (includes illus. nos. 1, 2 and 6)
	881725	1	White Lint Door Assembly for models with Door Lock (includes illus. nos. 1, 2 and 6)
	881812	1	Blue Lint Door Assembly for models with Door Lock (includes illus. nos. 1, 2 and 6)
2	117605	6	1/4" Noise Suppressor Tape (sold by the foot)
3	800150	1	Knob Latch Kit (includes illus. nos. 3 and 4)
4	160009	1	Lock Cam ONLY
5	160001	1	Lint Door Lock with Key
6	881723	1	White Lint Door Front Panel
	881810	1	Blue Lint Door Front Panel
7	150309	11	#10-16 x 1/2" Hex Head TEK Crimptite Screw
8	122116	1	Normally Open (N.O.) Lint Door Switch - 24 VAC
9	300400	1	Lint Door Switch Bracket
10	390136	1	Lint Door Switch Bracket Cover
11	150301	2	#8 x 7/16" Phillips Pan Head TEK Screw
12	-----	1	Sensor Bracket (refer to <b>Sensor Bracket Assembly</b> on <a href="#">page 5</a> )
13	824807	1	Rotational Sensor Assembly
14	881734	1	Lint Screen (15-7/8" x 37") with foam gasket For models mfd. as of August 22, 1997
	881733	1	Lint Screen (16-3/8" x 37") with foam gasket For models mfd. prior to August 22, 1997
15	115900	3	Drive Wheel Felt
16	152000	12	Pop Rivet
17	102358	1	Wrapper Gasket

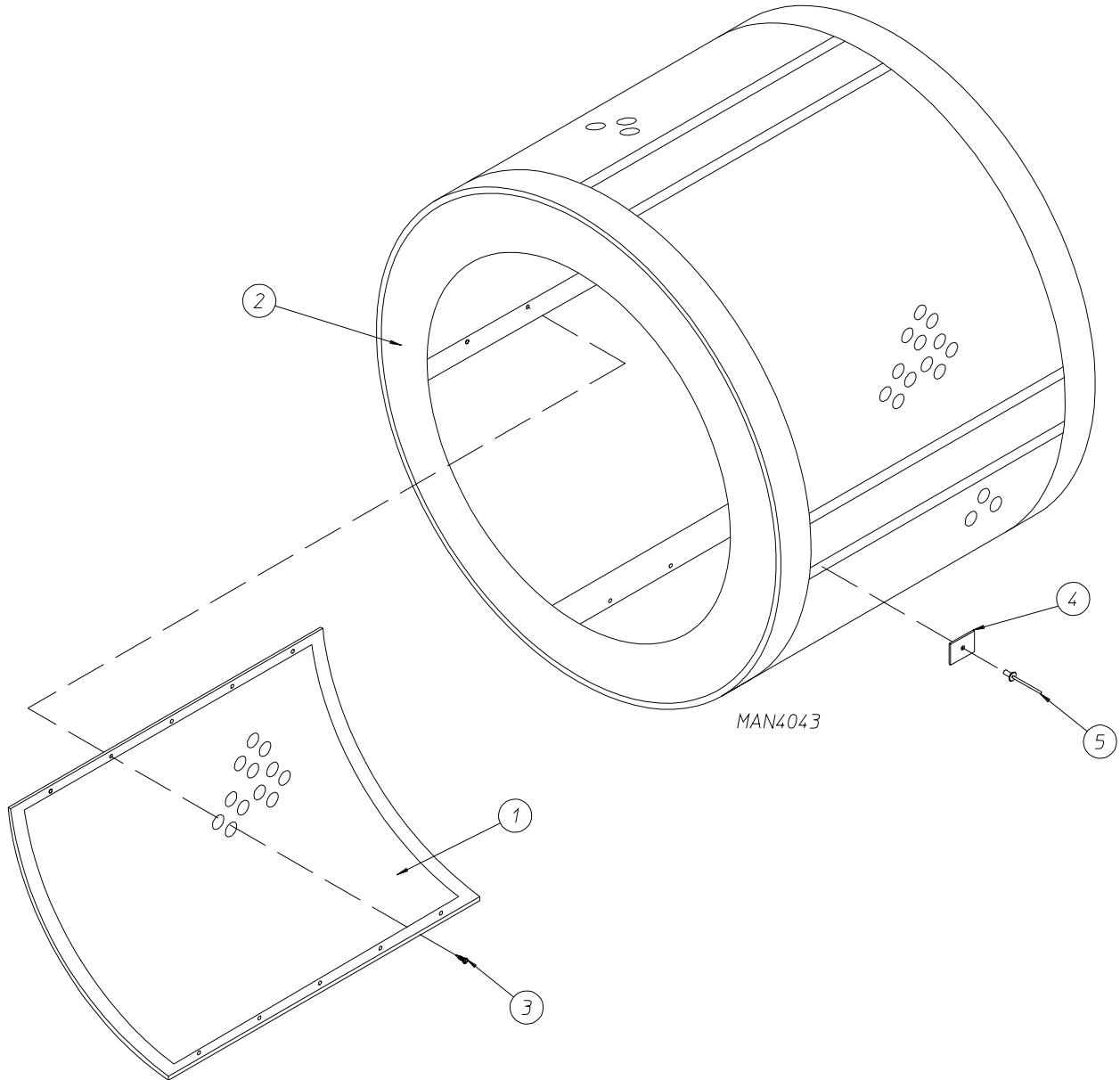

<u>Illus. No.</u>	<u>Part No.</u>	<u>Qty.</u>	<u>Description</u>
1	882100	4	Basket (Tumbler) Side
	170068	4	Stainless Steel Basket (Tumbler) Side
2	881722	1	Basket (Tumbler) Assembly (includes illus. nos. 1 through 3)
	881703	1	Basket (Tumbler) Weldment ( <i>does not</i> include illus. nos. 1 and 3)
	881721	1	Stainless Steel Basket (Tumbler) Assembly (includes illus. nos. 1 through 3)
	881767	1	Stainless Steel Basket (Tumbler) Weldment ( <i>does not</i> include illus. nos. 1 and 3)
3	150123	40	1/4-20 x 1/4" Socket Button Head Screw
4	102102	1	Rotational Sensor Magnet
5	154200	1	5/32" Pop Rivet



Between September 15, 1997 and April 6, 1998

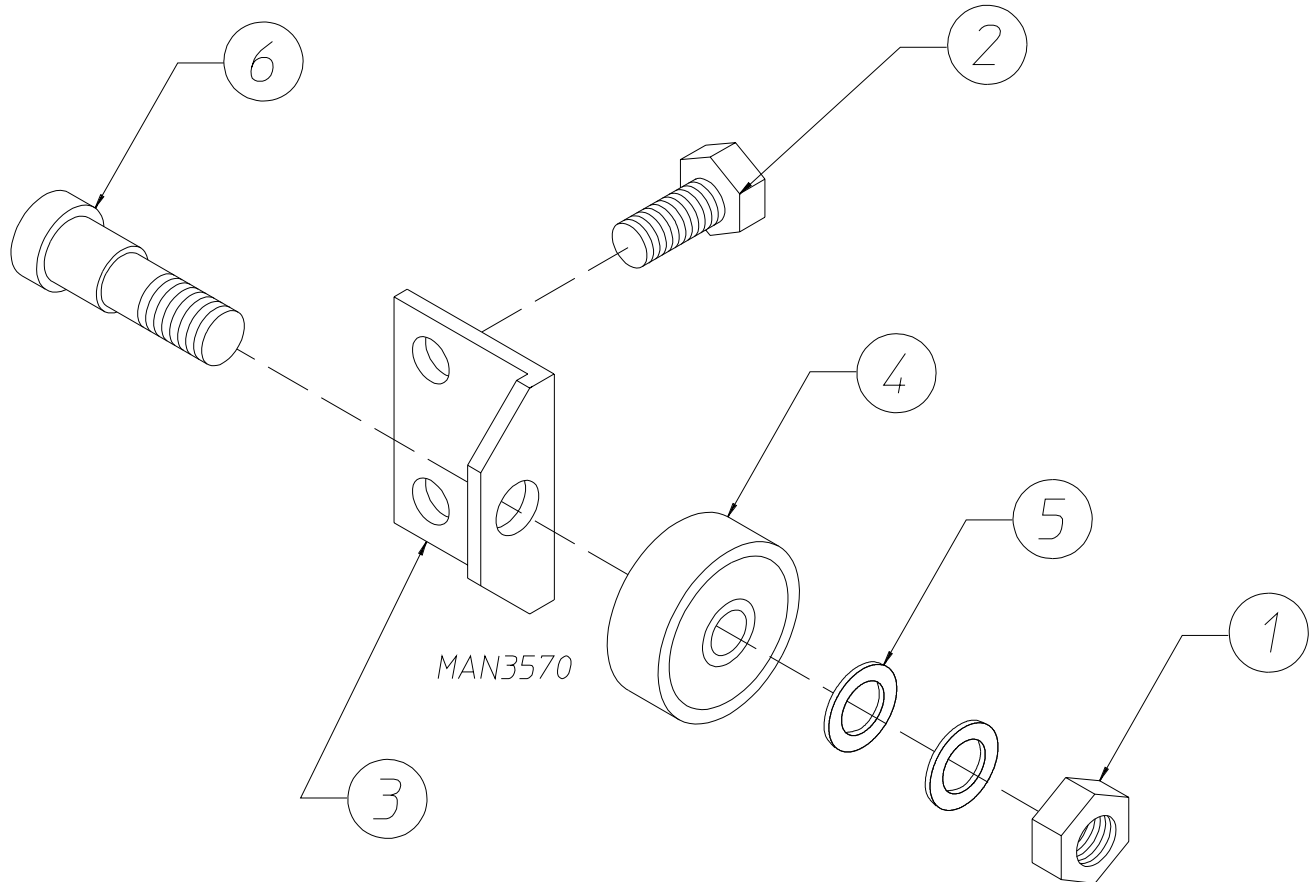

<u>Illus. No.</u>	<u>Part No.</u>	<u>Qty.</u>	<u>Description</u>
1	150220	2	3/8-24 Hex Nut (for models with 3/8" Hardware)
	152004	2	5/16" Hex Nut (for models with 5/16" Hardware)
2	150501	2	5/16-18 x 3/4" Hex Head Machine Bolt
3	882096	2	Front Thruster Wheel Bracket
4	-----	2	Front Thruster Wheel Assembly Complete (discontinued) Use wheel assembly on <b>page 19</b>
	-----	2	Front Thruster Wheel with hardware (includes illus. nos. 1, 4 and 5) Use wheel assembly on <b>page 19</b>
5	153001	2	5/16" Flat Washer
6	154277	2	5/16" x 3/8" Shoulder Bolt

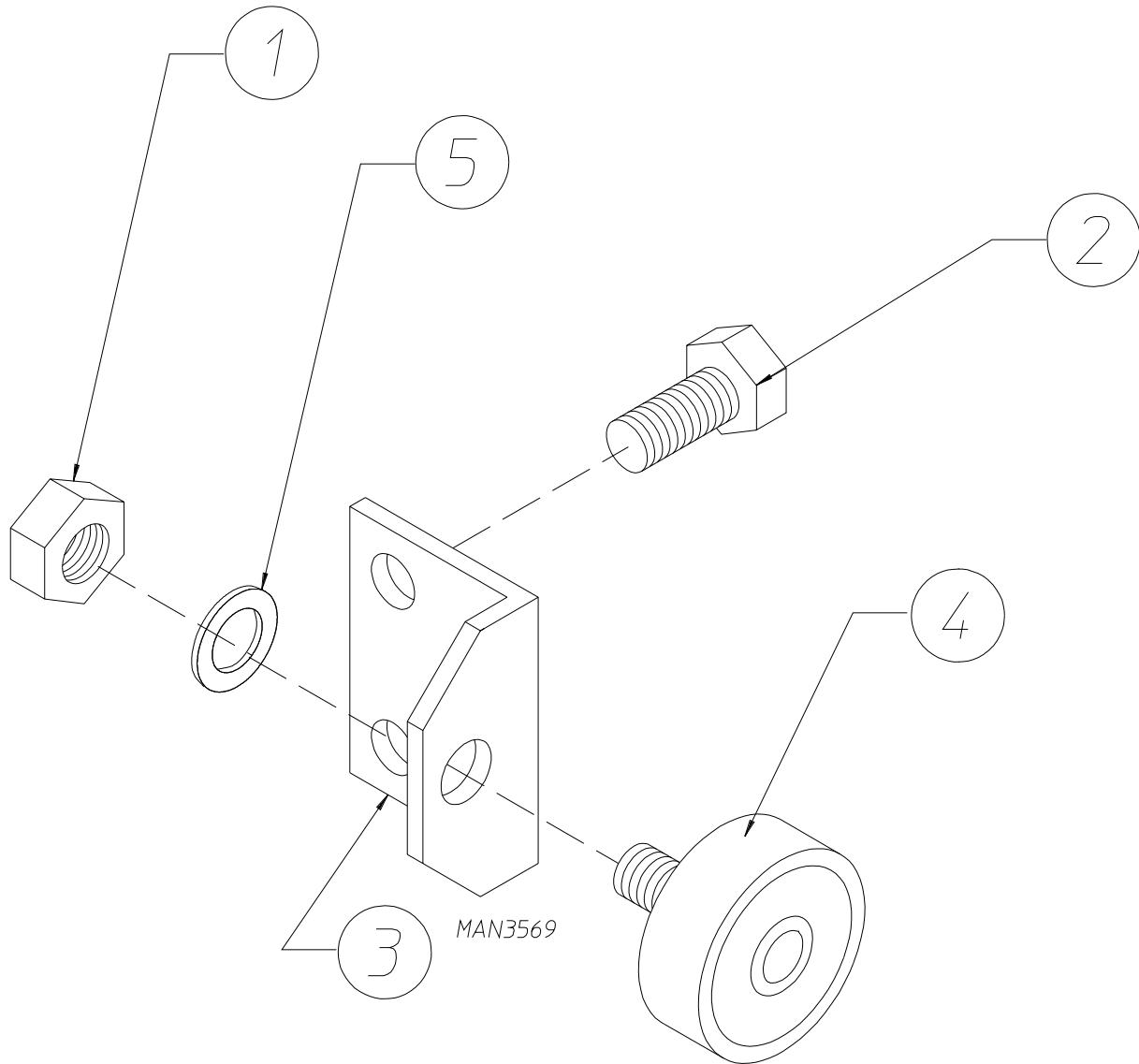

<u>Illus. No.</u>	<u>Part No.</u>	<u>Qty.</u>	<u>Description</u>
1	152004	1	5/16" Hex Nut
2	150501	2	5/16-18 x 3/4" Hex Head Machine Bolt
3	882097	1	Front Thruster Wheel Bracket
4	881758	1	Front Thruster Wheel Assembly
	180046	1	Front Thruster Wheel ONLY
5	153001	1	5/16" Flat Washer

Between September 15, 1997 and April 6, 1998

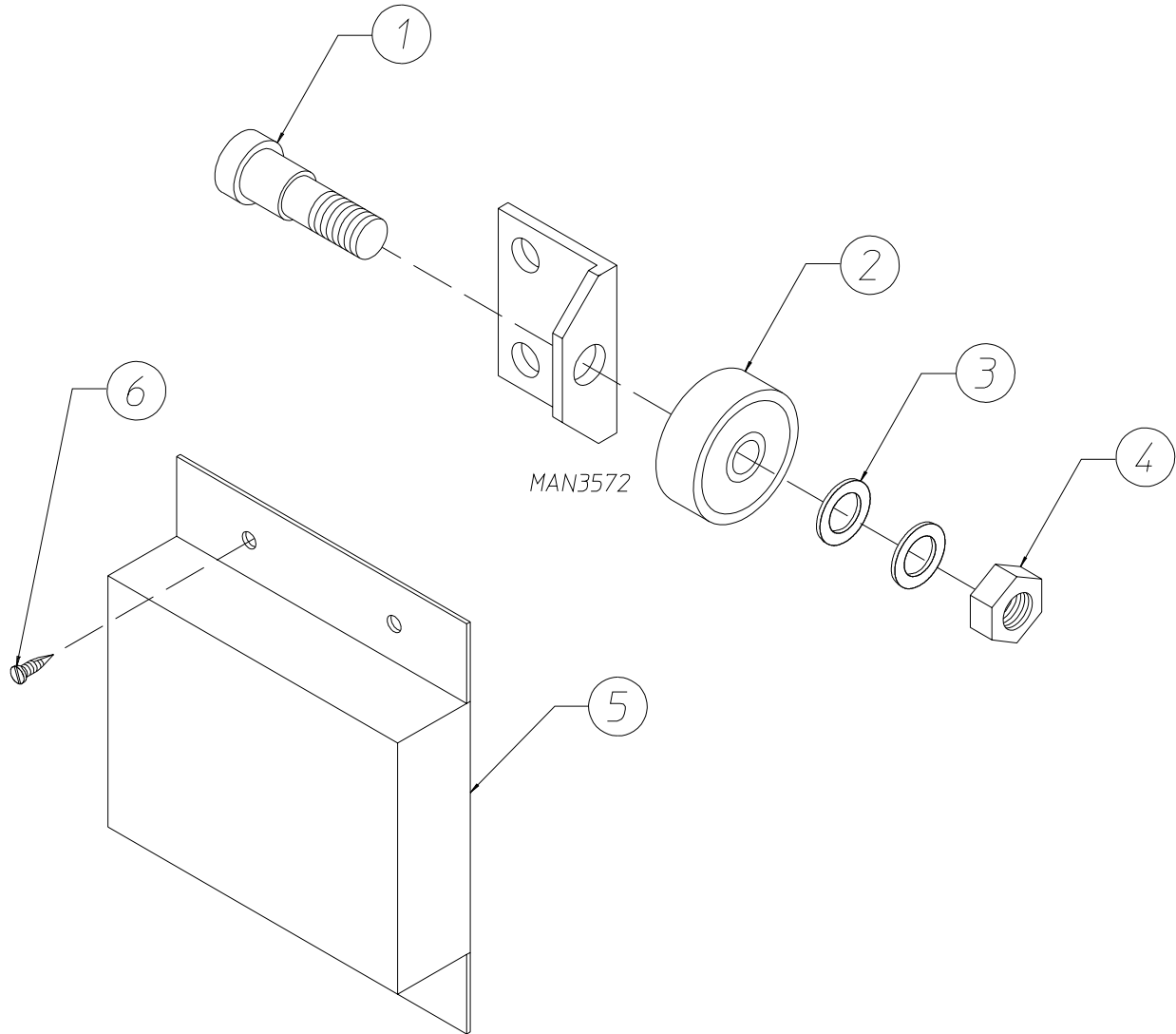

Illus. No.	Part No.	Qty.	Description
1	154277	1	5/16" x 3/8" Shoulder Bolt
2	-----	1	Rear Thruster Wheel with hardware (use wheel assembly on <b>page 20</b> )
3	153001	2	5/16" Flat Washer
4	150220	2	3/8-24 Hex Nut (for models with 3/8" Hardware)
	152004	2	5/16" Hex Nut (for models with 5/16" Hardware)
5	881752	1	White Rear Thruster Wheel Cover
	881753	1	Blue Rear Thruster Wheel Cover
6	150301	4	#8-18 x 7/16" Phillips Pan Head TEK Screw

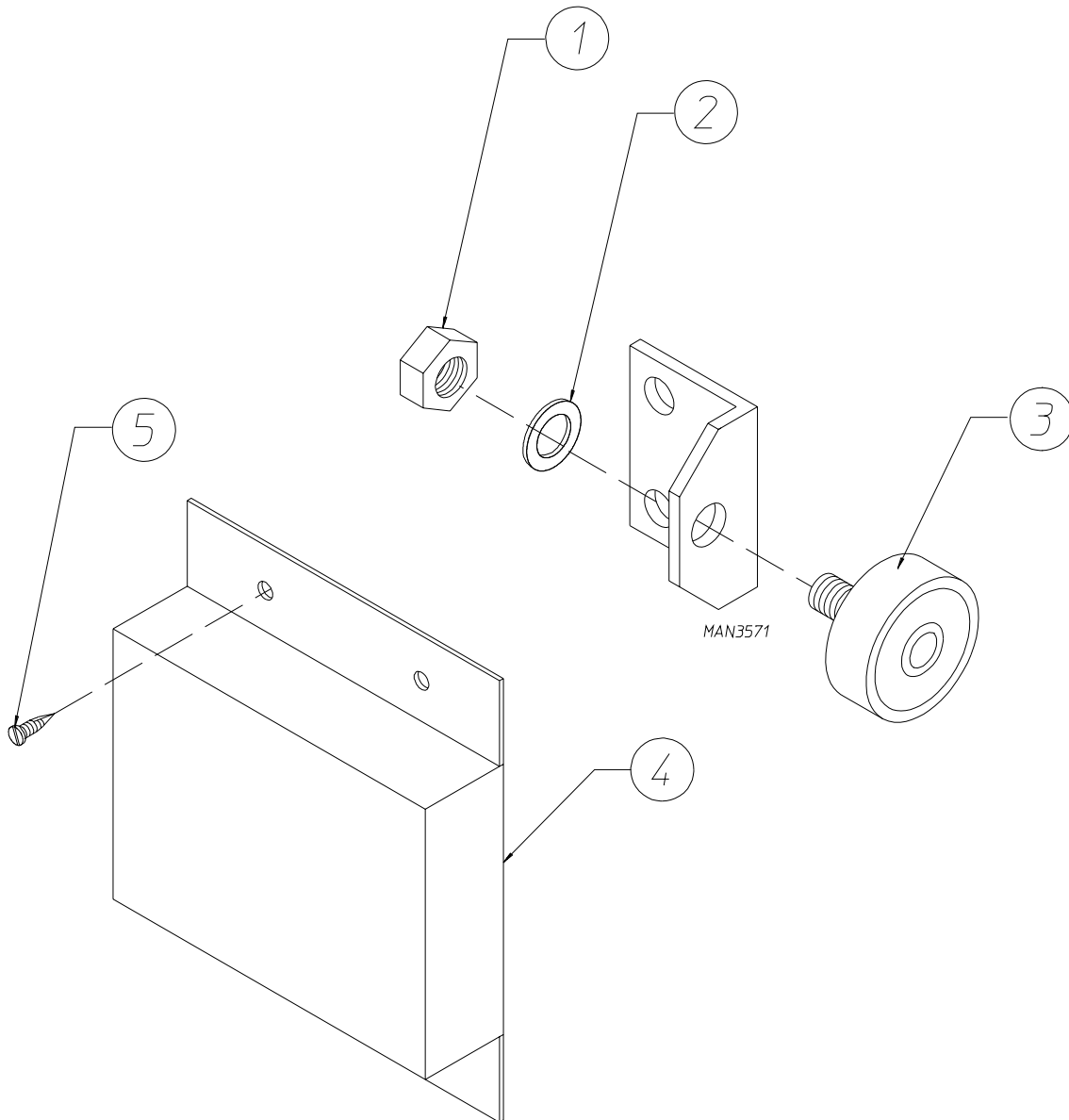

<u>Illus. No.</u>	<u>Part No.</u>	<u>Qty.</u>	<u>Description</u>
1	152004	1	5/16" Hex Nut
2	153001	1	5/16" Flat Washer
3	180046	1	Rear Thruster Wheel ONLY
4	881752	1	White Rear Thruster Wheel Cover
	881753	1	Blue Rear Thruster Wheel Cover
5	150301	4	#8-18 x 7/16" Phillips Pan Head TEK Screw

As of April 6, 1998

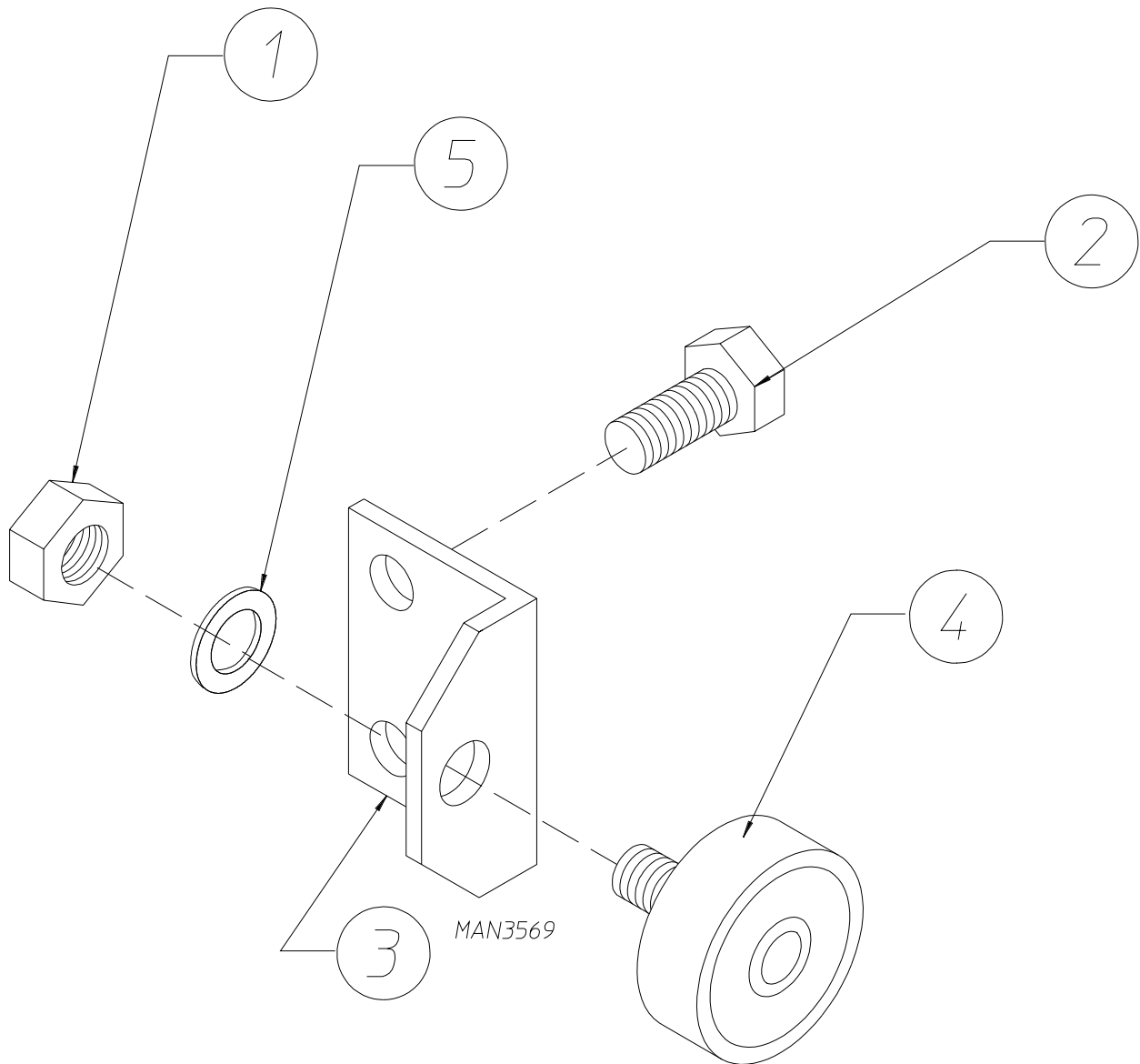

<u>Illus. No.</u>	<u>Part No.</u>	<u>Qty.</u>	<u>Description</u>
1	150220	1	3/8-24 Hex Nut
2	150501	2	5/16-18 x 3/4" Hex Head Machine Bolt
3	882096	1	Front Thruster Wheel Bracket
4	881720	1	Front Thruster Wheel Assembly (includes illus. nos. 1 and 3 through 5)
	881988	1	Front Thruster Wheel ONLY (includes illus. nos. 1, 4 and 5)
5	153001	1	5/16" Flat Washer

As of April 6, 1998

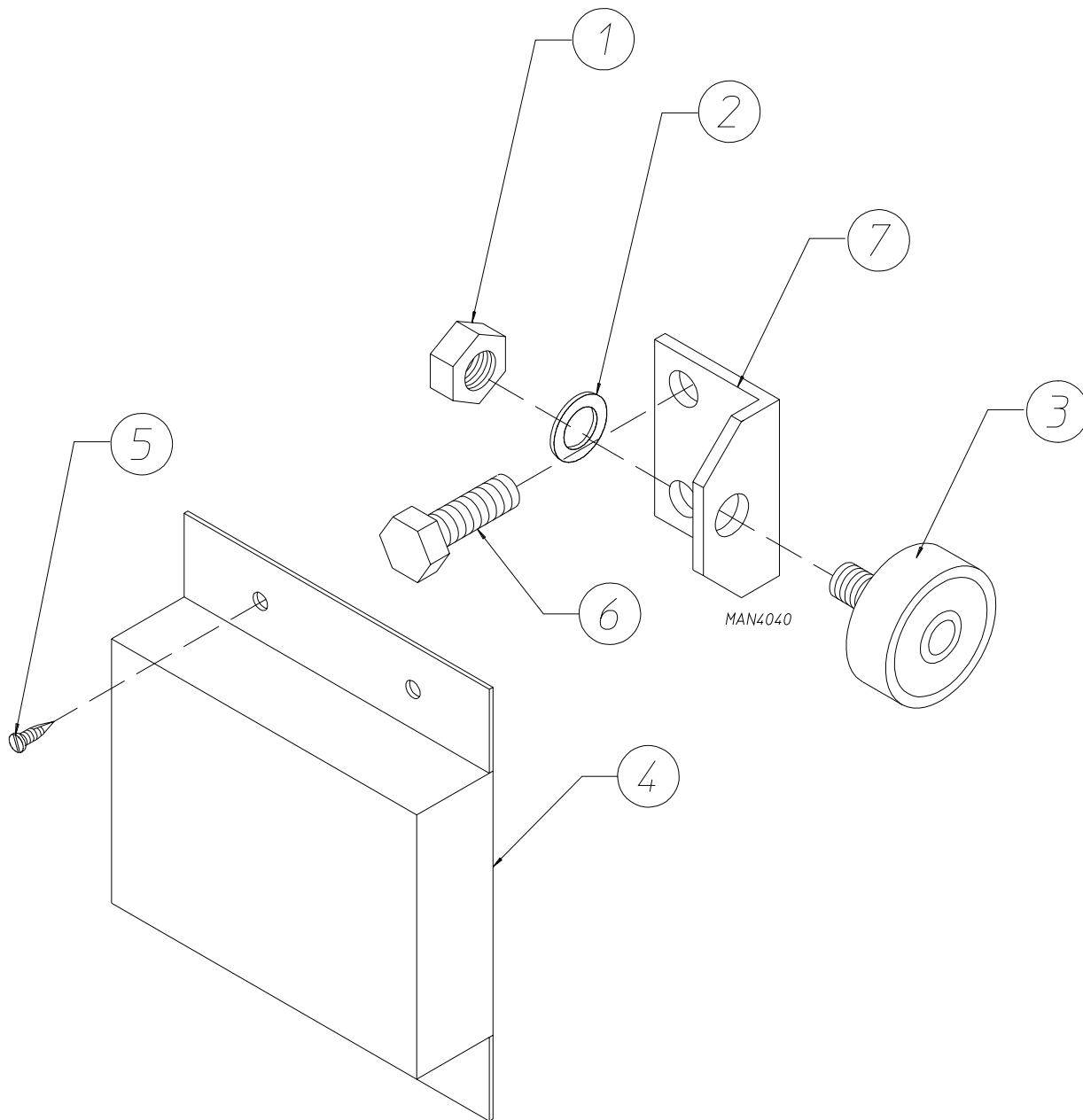

<u>Illus. No.</u>	<u>Part No.</u>	<u>Qty.</u>	<u>Description</u>
1	150220	1	3/8-24 Hex Nut
2	153001	1	5/16" Flat Washer
3	881988	1	Front Thruster Wheel Only (includes illus. nos 1 through 3)
4	881752	1	White Rear Thruster Wheel Cover
	881753	2	Blue rear Thruster Wheel Cover
5	150301	4	#8-18 x 7/16" Phillips Pan Head Screw
6	150501	2	5/16-18 x 3/4" Hex Head Machine Bolt
7	882096	2	Front Thruster Wheel Bracket

As of December 15, 1997

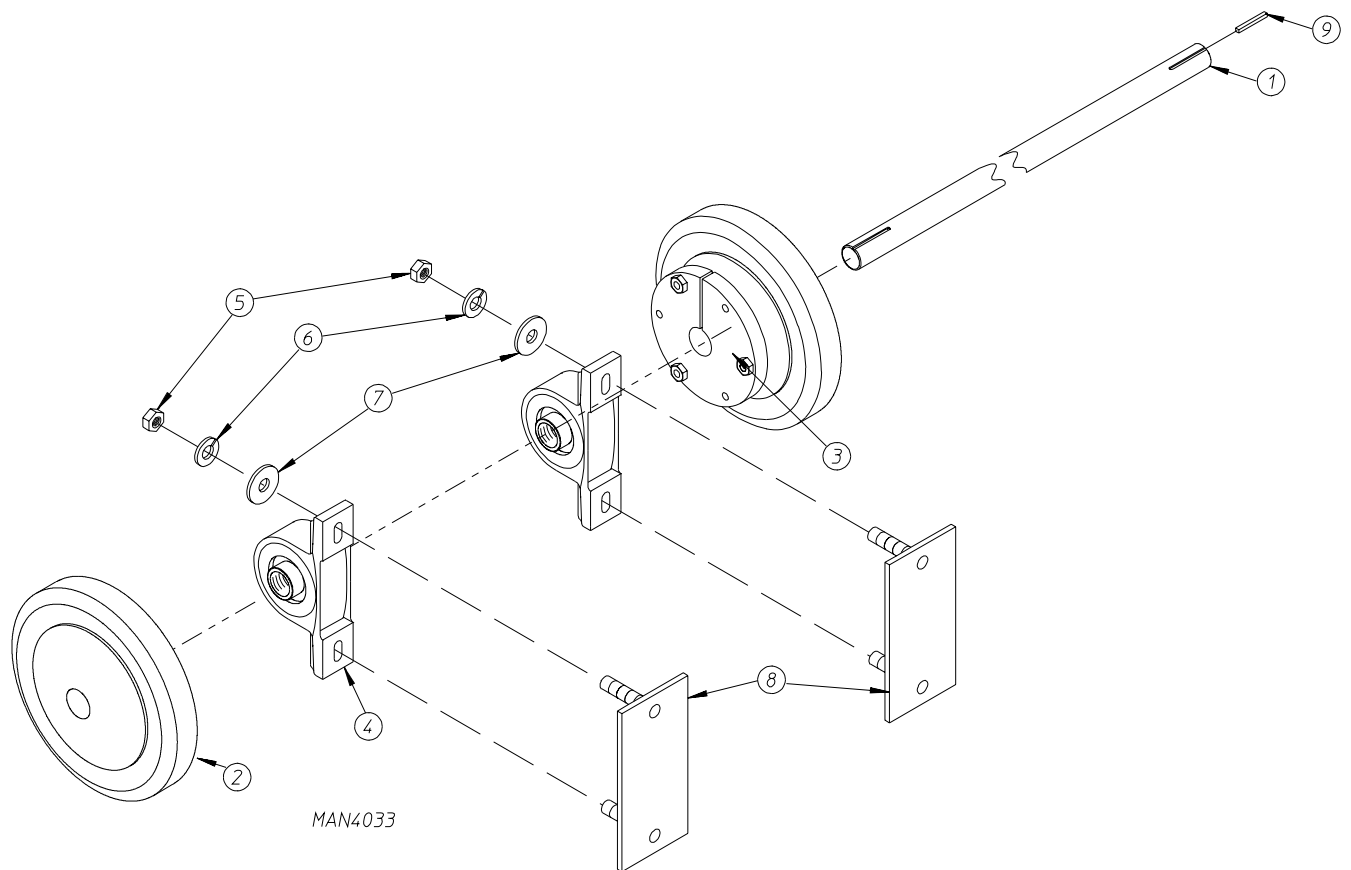

<u>Illus. No.</u>	<u>Part No.</u>	<u>Qty.</u>	<u>Description</u>
1	881825	1	Idler Shaft Assembly Complete (includes illus. nos. 1 through 7) For models mfd. as of December 15, 1997
	390134	1	Drive Shaft Only
2	180037	2	6" Drive Wheel
3	180038	2	1" Taperlock
4	880205	2	1" Pillow Block Bearing
5	152004	4	5/16 - 18 Hex Nut
6	153002	4	5/16" Lock Washer
7	153001	4	5/16" flat Washer
8	859008	2	Bearing Bolt Plate Assembly
9	100704	2	1/4" x 1/4" x 1 3/4" Key

Prior to December 15, 1997

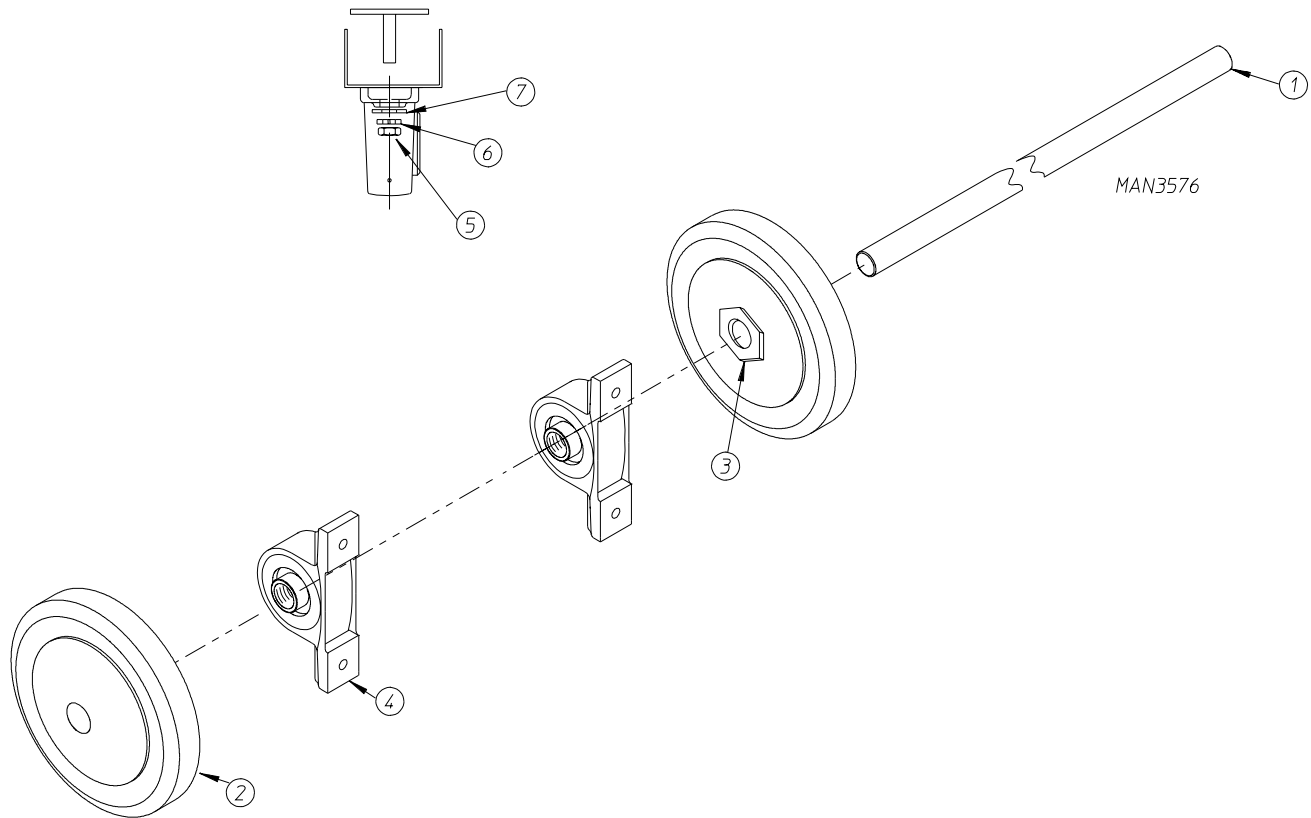

Illus. No.	Part No.	Qty.	Description
1	881718	1	Idler Shaft Assembly Complete (includes illus. nos. 1 through 7) For models mfd. prior to December 15, 1997
	390009	1	Idler Shaft ONLY
2	180039	2	6" Wheel
3	180006	2	1" Trantorque
4	100205	2	1" Pillow Block Bearing
5	152004	4	5/16" Hex Nut
6	153002	4	5/16" Lock Washer
7	153001	4	5/16" Flat Washer



As of December 15, 1997

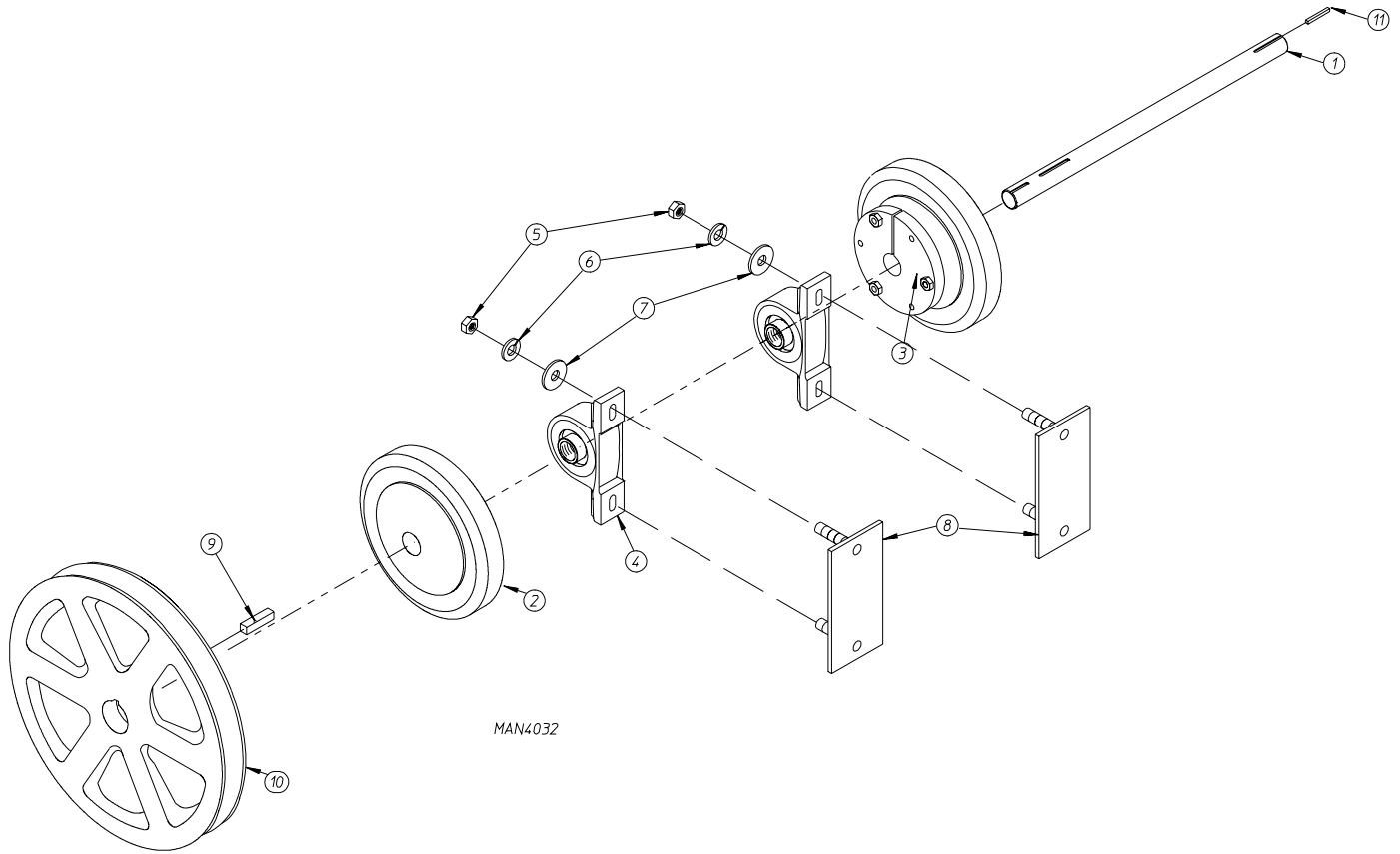

<u>Illus. No.</u>	<u>Part No.</u>	<u>Qty.</u>	<u>Description</u>
1	881826	1	Drive Shaft Assembly Complete (includes illus. nos. 1 through 11)
	390154	1	Drive Shaft Only
2	180037	2	6" Drive Wheel
3	180038	2	1" Taperlock
4	880205	2	1" Pillow Block Bearing
5	152004	4	5/16"-18 Hex Nut
6	153002	4	5/16" Lock Washer
7	153001	4	5/16" Flat Washer
8	859008	2	Bearing Bolt Plate Assembly
9	100700	1	1/4" x 1/4" x 1 1/16" Key
10	101209	1	9" Pulley
11	100704	2	1/4" x 1/4" x 1 3/4" Key

Prior to December 15, 1997

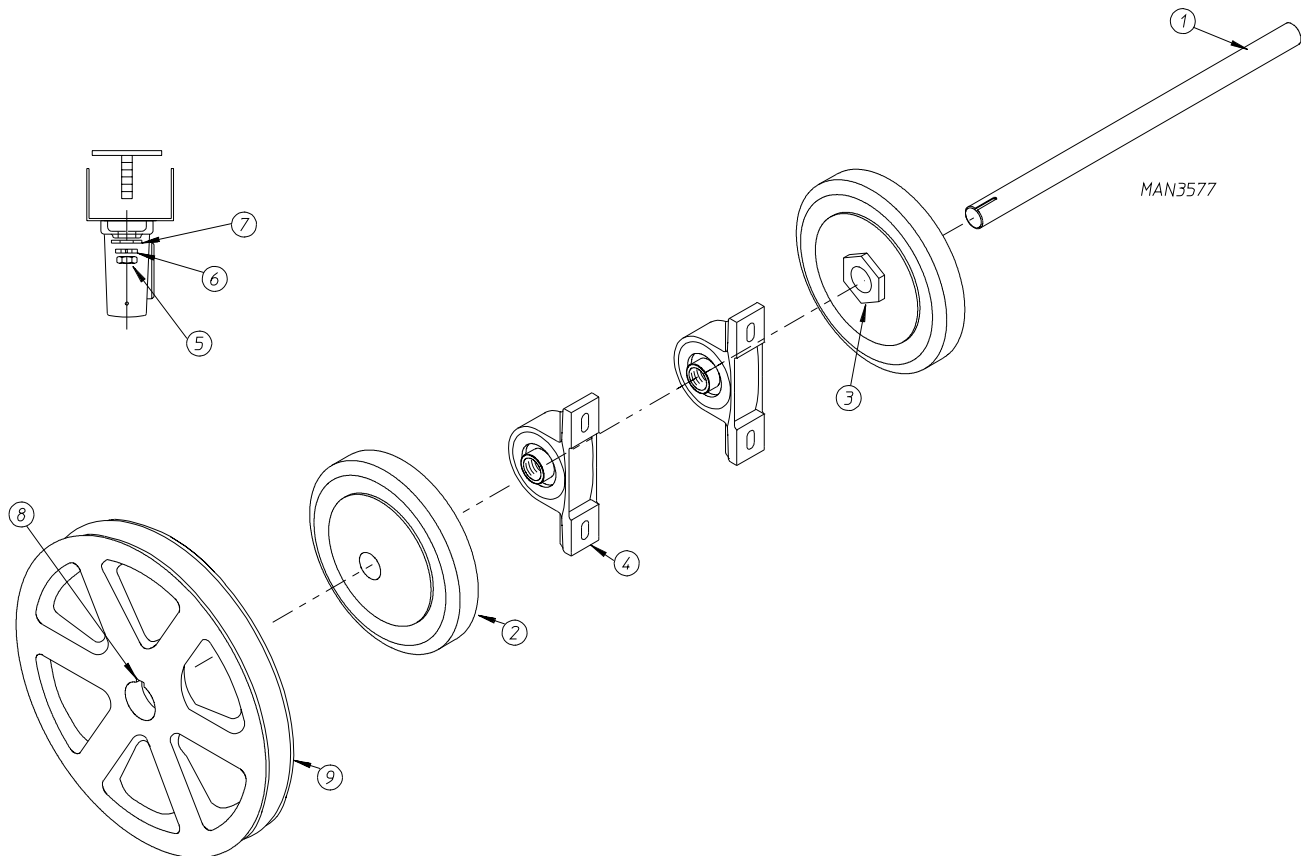

<u>Illus. No.</u>	<u>Part No.</u>	<u>Qty.</u>	<u>Description</u>
1	881717	1	Drive Shaft Assembly Complete (includes illus. nos. 1 through 9) For models mfd. prior to December 15, 1997
	390008	1	Drive Shaft ONLY
2	180039	2	6" Wheel
3	180006	2	1" Trantorque
4	880205	2	1" Pillow Block Bearing
5	152004	4	5/16" Hex Nut
6	153002	4	5/16" Lock Washer
7	153001	4	5/16" Flat Washer
8	100700	1	1/4" x 1/4" x 1-1/16" Key
9	101209	1	9" Pulley

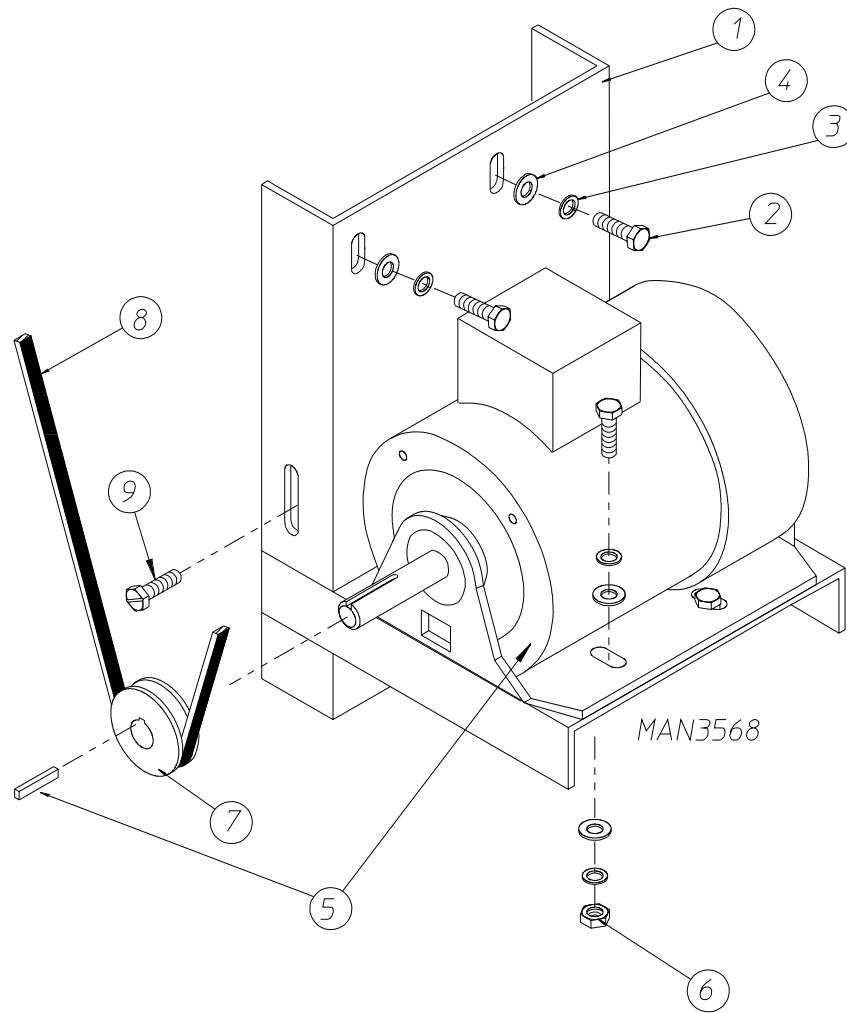

Illus. No.	Part No.	Qty.	Description
1	881715	1	Drive Motor Assembly Complete - 60 Hz (includes illus. nos. 1 through 7 and 9)
	881716	1	Drive Motor Assembly Complete - 50 Hz (includes illus. nos. 1 through 7 and 9)
	859012	1	Drive Motor Mount Assembly ONLY
2	150501	7	5/16-18 x 3/4" Hex Head Machine Bolt
3	153002	11	5/16" Lock Washer
4	153001	11	5/16" Flat Washer
5	181106	1	1/2 HP / 3ø / 50/60 Hz Totally Enclosed, Fan-Cooled (T.E.F.C) Motor
6	152004	4	5/16" Hex Nut
7	101132	1	5/8" Bore x 2" Pulley - 60 Hz
	101130	1	5/8" Bore x 2-1/2" Pulley - 50 Hz
8	100174	1	AX-53 Cogged Belt - 60 Hz (for models mfd. as of August 8, 1997)
	100151	1	AX-54 Cogged Belt - 60 Hz (for models mfd. prior to August 8, 1997)
	100174	1	AX-54 Cogged Belt - 50 Hz (for models mfd. as of May 13, 1998)
	100175	1	AX-55 Cogged Belt - 50 Hz (for models mfd. prior to May 13, 1998)
9	150523	1	1/4-20 x 3/4" Hex Washer TEK Screw

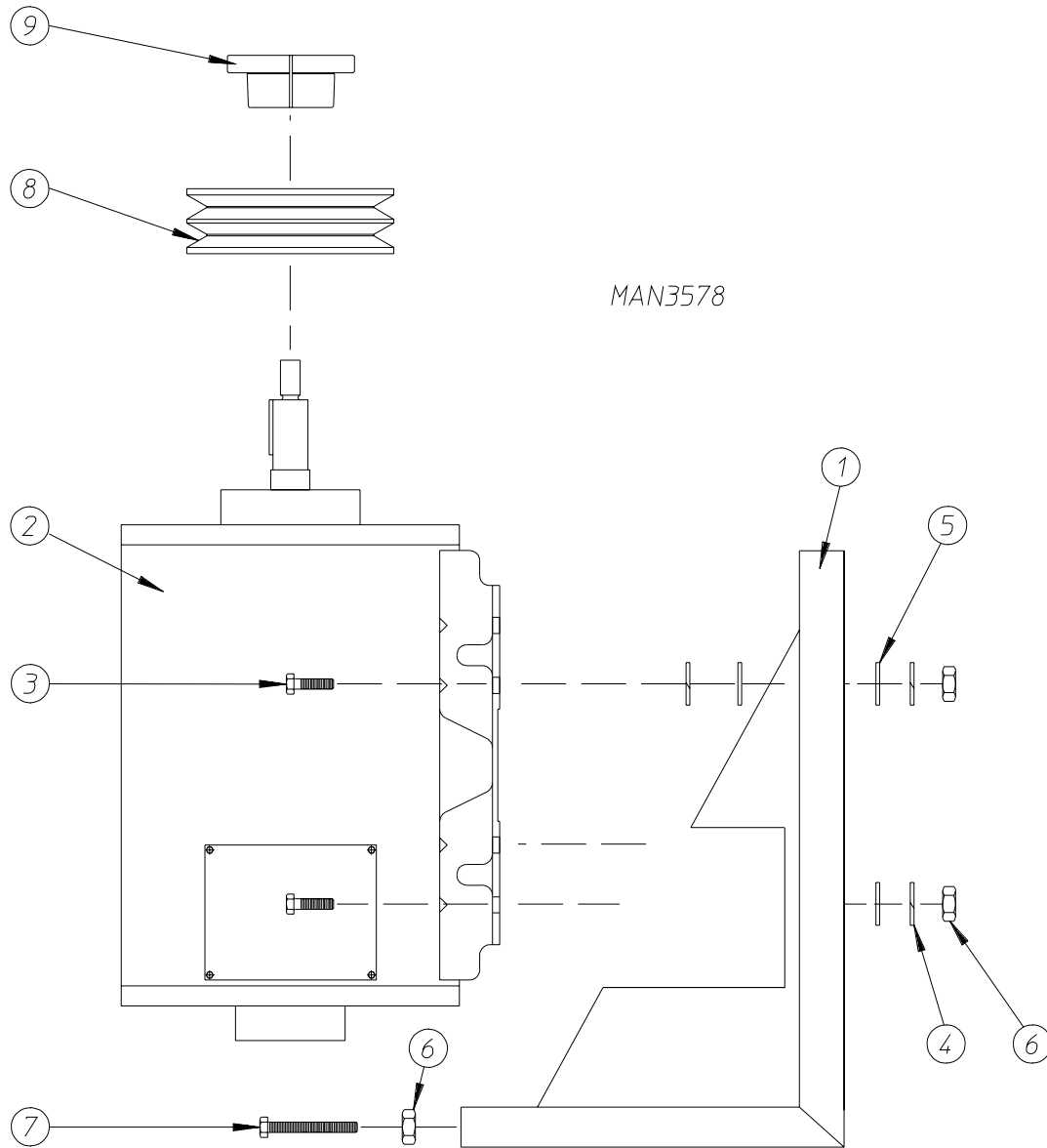

Illus. No.	Part No.	Qty.	Description
1	881713	1	Blower (Fan/Impellor) Motor Assembly Complete - 60 Hz (includes illus. nos. 1 through 9)
	881714	1	Blower (Fan/Impellor) Motor Assembly Complete - 50 Hz (includes illus. nos. 1 through 9)
	859039	1	Blower (Fan/Impellor) Motor Slide Assembly ONLY
2	181105	1	3 HP / 3 $\phi$ / 50/60 Hz Totally Enclosed, Non-Vent (T.E.N.V.) Motor
3	150504	4	5/18-18 x 1" Hex Head Machine Bolt
4	153002	8	5/16" Lock Washer
5	153001	8	5/16" Flat Washer
6	152004	6	5/16" Hex Nut
7	150514	2	5/16-18 X 2-1/4" Hex Bolt
8	101135	1	2B x 5.4 Pulley - 60 Hz
	101185	1	2B x 6.2 Pulley - 50 Hz
9	101194	1	1-3/8" x SDS Bushing

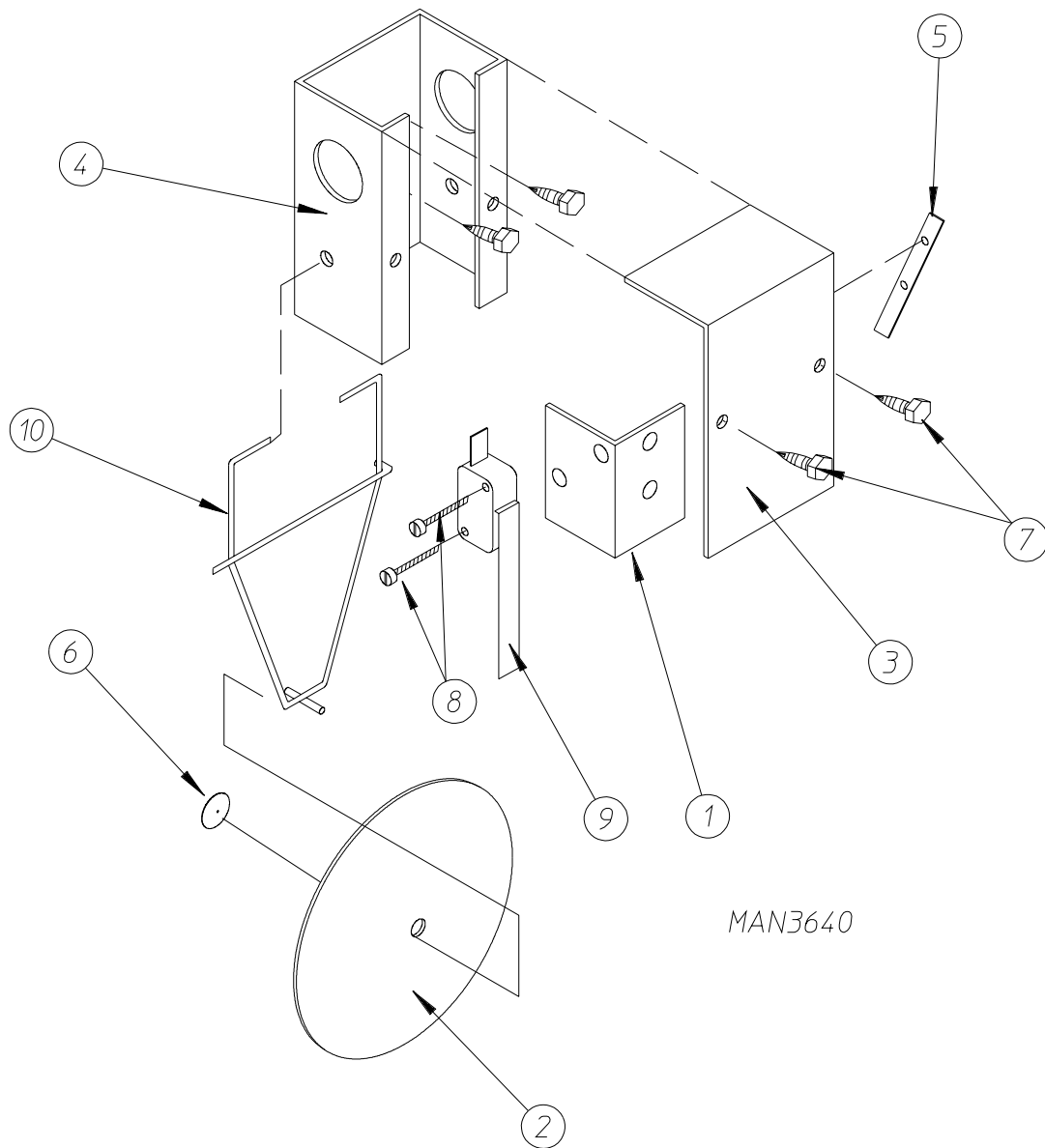

MAN3640

<u>Illus. No.</u>	<u>Part No.</u>	<u>Qty.</u>	<u>Description</u>
1	319203	1	Sail Switch Mounting Bracket
2	319202	1	Sail Switch Damper (flat)
3	319201	1	Sail Switch Box Cover
4	319200	1	Sail Switch Box
5	154004	1	Twin Speed Nut
6	154002	1	1/8" Push-on Fastener
7	150309	4	#10-16 x 1/2" Hex Head TEK Crimptite Screw
8	150303	2	#4 x 3/4" Pan Head "A" Machine Screw
9	122200	1	Sail Switch ONLY
	881706	1	Sail Switch Box Assembly Complete (includes illus. nos. 1 through 10)
10	105500	1	Sail Switch Actuator Rod

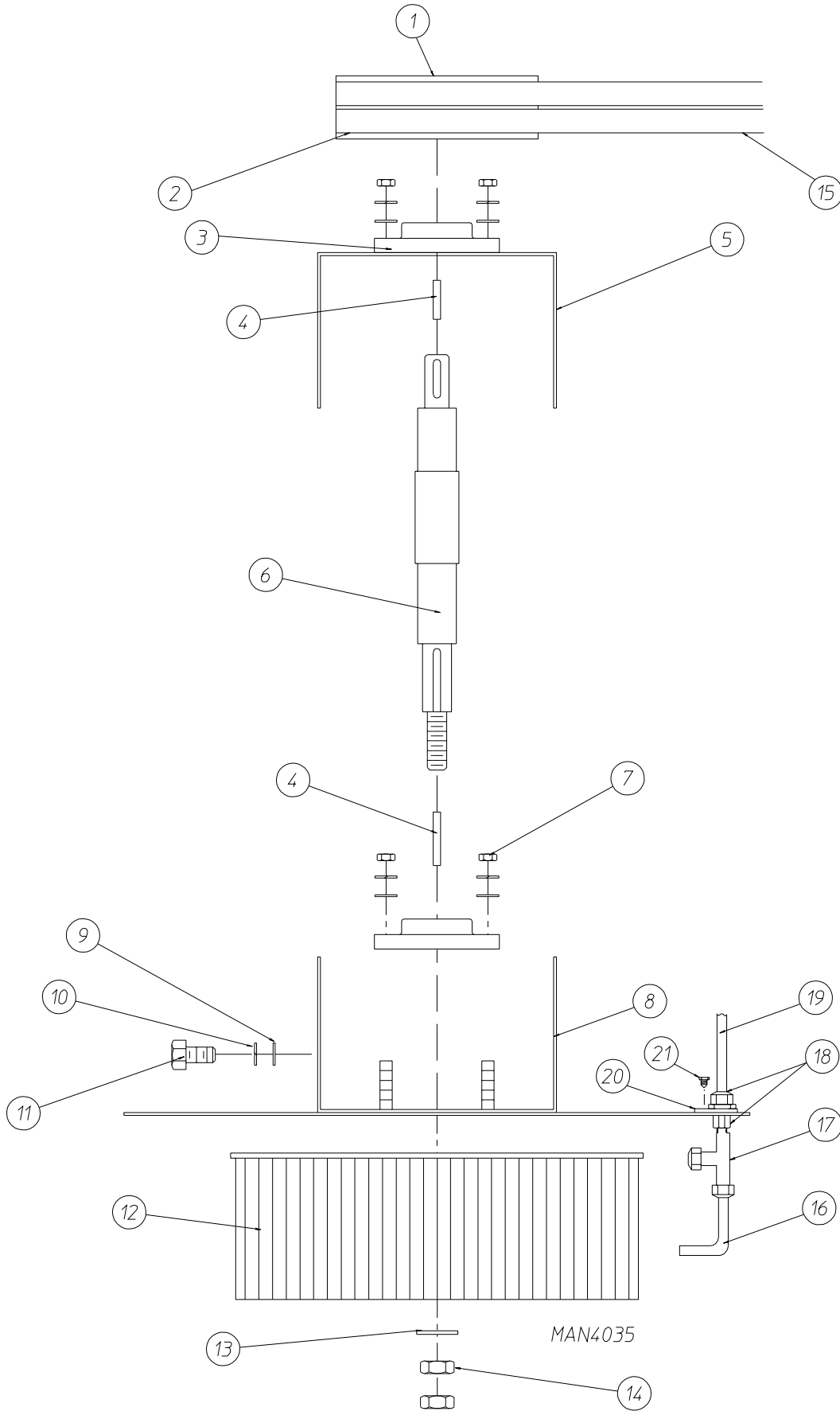

---

**As of July 1, 1998**

<u>Illus. No.</u>	<u>Part No.</u>	<u>Qty.</u>	<u>Description</u>
1	101215	1	5/8" x SH Bushing
2	101216	1	2B x 4.2 Pulley - 50/60 Hz
3	100240	2	1" Flange Bearing
4	100701	2	3/16" x 3/16" x 1" Key
5	859014	1	Idler Mount - Top
6	390053	1	Impellor (Fan/Blower) Shaft
7	152004	8	5/16-18 Hex Nut
8	859013	1	Impellor (Fan/Blower) Cover
9	153001	12	5/16" Flat Washer
10	153002	12	5/16" Lock Washer
11	150501	4	5/16-18 x 3/4" Hex Head Machine Bolt
12	100615	1	9-15/16" x 5" Squirrel Cage Fan (Impellor/Blower)
	881711	1	Blower (Fan/Impellor) Wheel Assembly Complete - 60 Hz (includes illus. nos. 1 through 14)
	881712	1	Blower (Fan/Impellor) Wheel Assembly Complete - 50 Hz (includes illus. nos. 1 through 14)
13	153050	1	1/2" Flat Washer
14	152012	2	1/2-20 Hex Nut
15*	100149	2	BX-44 Cogged Belt - 60 Hz
	100176	2	BX-46 Cogged Belt - 50 Hz
16	143100	2.5"	1/4" Aluminum Tubing
17	143287	1	Tee Fitting
18	143259	2	Bulkhead Fitting
19	143110	9'	1/4" Poly Flo Tubing
20	882101	1	Air Jet Mounting Plate
21	150309	2	#10-16 x 1/2 Hex Head Crimptite Screw

\* Replace in matched sets (both belts).

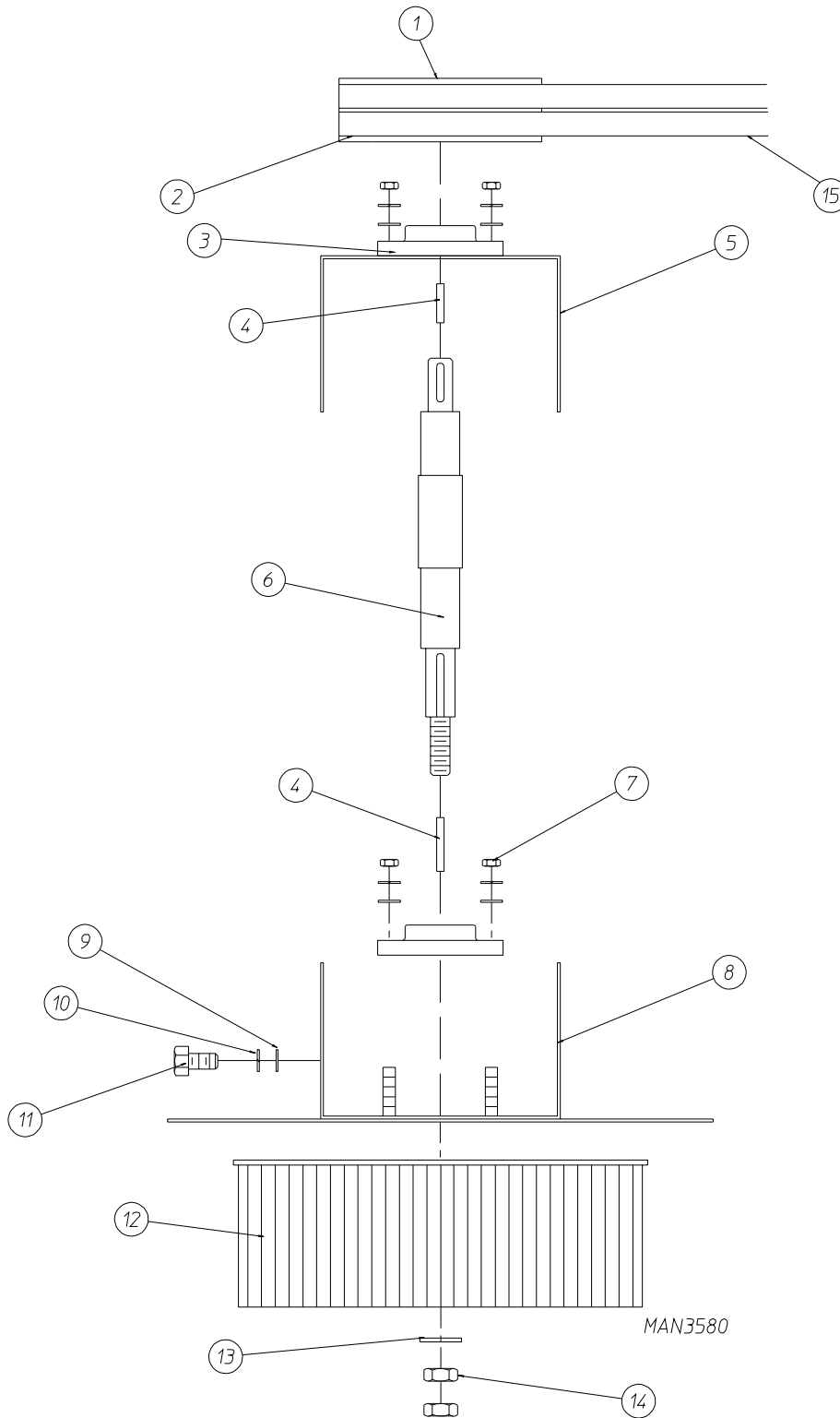



---

**Prior to July 1, 1998**

<u>Illus. No.</u>	<u>Part No.</u>	<u>Qty.</u>	<u>Description</u>
1	101215	1	5/8" x SH Bushing
2	101216	1	2B x 4.2 Pulley - 50/60 Hz
3	100240	2	1" Flange Bearing
4	100701	2	3/16" x 3/16" x 1" Key
5	859014	1	Idler Mount - Top
6	390053	1	Impellor (Fan/Blower) Shaft
7	152004	8	5/16-18 Hex Nut
8	859013	1	Impellor (Fan/Blower) Cover
9	153001	12	5/16" Flat Washer
10	153002	12	5/16" Lock Washer
11	150501	4	5/16-18 x 3/4" Hex Head Machine Bolt
12	100615	1	9-15/16" x 5" Squirrel Cage Fan (Impellor/Blower)
	881711	1	Blower (Fan/Impellor) Wheel Assembly Complete - 60 Hz (includes illus. nos. 1 through 14)
	881712	1	Blower (Fan/Impellor) Wheel Assembly Complete - 50 Hz (includes illus. nos. 1 through 14)
13	153050	1	1/2" Flat Washer
14	152012	2	1/2-20 Hex Nut
15*	100149	2	BX-44 Cogged Belt - 60 Hz
	100176	2	BX-46 Cogged Belt - 50 Hz

\* Replace in matched sets (both belts).

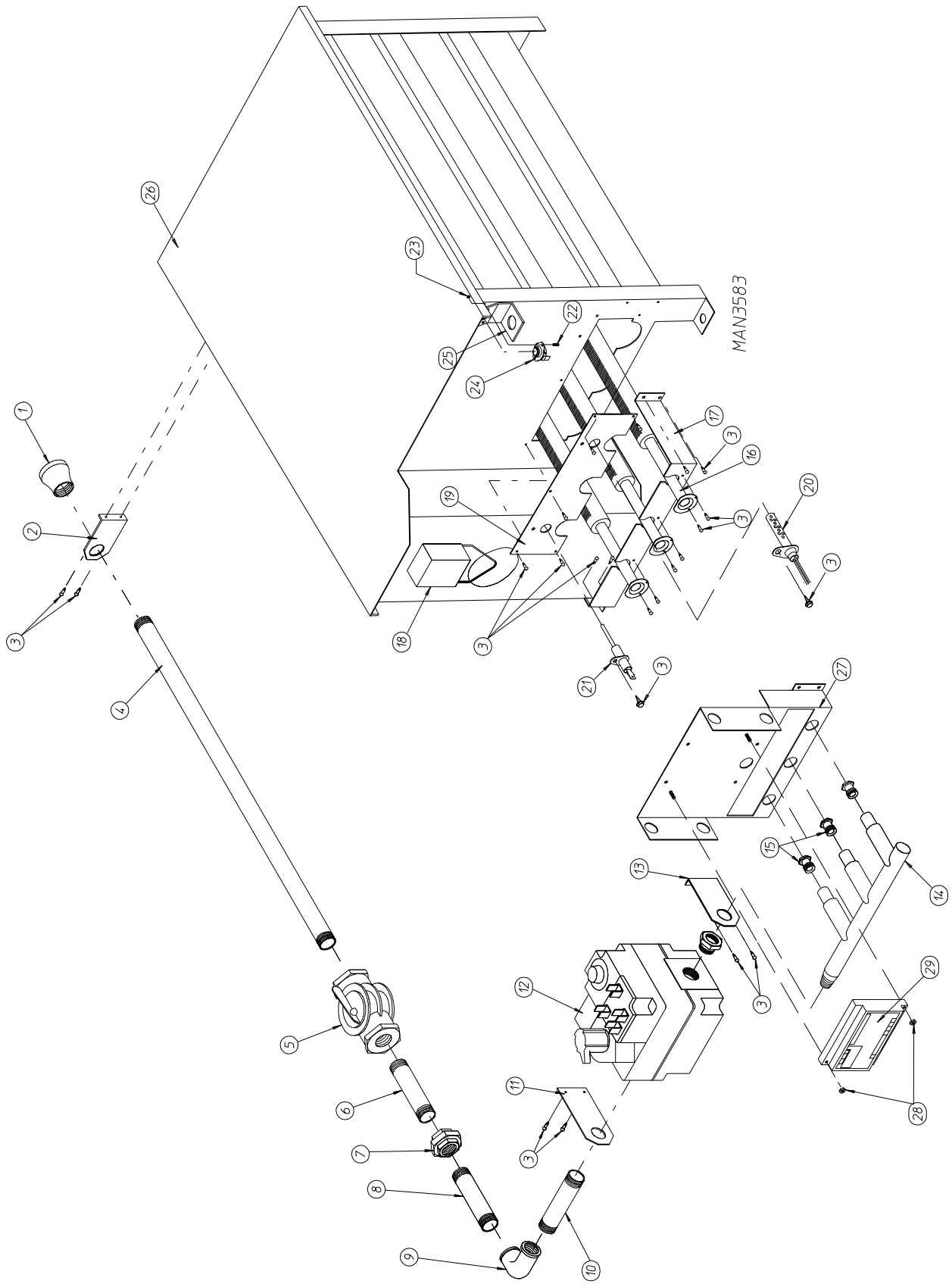

<u>Illus. No.</u>	<u>Part No.</u>	<u>Qty.</u>	<u>Description</u>
1	142924	1	1" to 3/4" Reducing Coupling
2	331291	1	Pipe Bracket
3	150309	20	#10-16 x 1/2" Hex Head TEK Crimptite Screw
4	142829	1	3/4" x 20" Nipple
5	141300	1	3/4" Union Shut-off
6	142701	1	3/4" Closed Nipple
7	142601	1	3/4" Union
8	142710	1	3/4" x 4" Nipple
9	142504	1	3/4" x 90° Elbow
10	142734	1	3/4" x 5-1/2" Nipple
11	390125	1	Pipe Bracket
12	140026	1	3/4" 24 VAC Redundant (natural gas) Gas Valve
	882098	1	3/4" x 24" VAC Redundant (L.P.) Gas Valves
	140411	1	24 VAC Gas Valve L.P. (liquid propane) Conversion Kit
13	331291	1	Pipe Bracket
14	141208	1	3-Port Manifold
15*	140836	3	#10 Burner Orifice (natural gas) ONLY
	140855	3	#33 Burner Orifice (liquid propane gas) ONLY
16	141123	3	Burner Tube ONLY
17	390124	1	Burner Tube Support ONLY
18	-----	1	Sail Switch (refer to <b>Sail Switch Assembly</b> on <b>page 27</b> )
19	390098	1	Burner Box Cover Plate ONLY
20	881597	1	Hot Surface Ignition (HSI) Ignitor
21	128921	1	HSI Flame Sensor
22	150001	2	#6-32 x 1/2" Phillips Round Head Machine Screw
23	151000	2	#6-32 Pal Nut
24	130401	1	330° Hi-Limit ONLY
25	319703	1	Hi-Limit Bracket
26	881709**	1	Natural Gas Burner Assembly Complete (includes illus. nos 1 through 14 and 16 through 29) For models mfd. with Natural Gas ONLY
	881708**	1	L.P. (liquid propane) Gas Burner Assembly Complete (includes illus. nos 1 through 14 and 16 through 29) For models mfd. with L.P. (liquid propane) Gas ONLY
	881707	1	Burner Box ONLY
	881498*	1	Hot Surface Ignition (HSI) L.P. Conversion Kit
27	335031	1	Hot Surface Ignition (HSI) Module Mounting Bracket/Manifold Rest
28	151001	2	#8-32 Pal Nut
29	881797	1	HSI (Hot Surface Ignition) Module II

\* Consult factory for elevations over 2,000 feet.

\*\* Burner assemblies do not include burner orifices, which must be ordered separately.

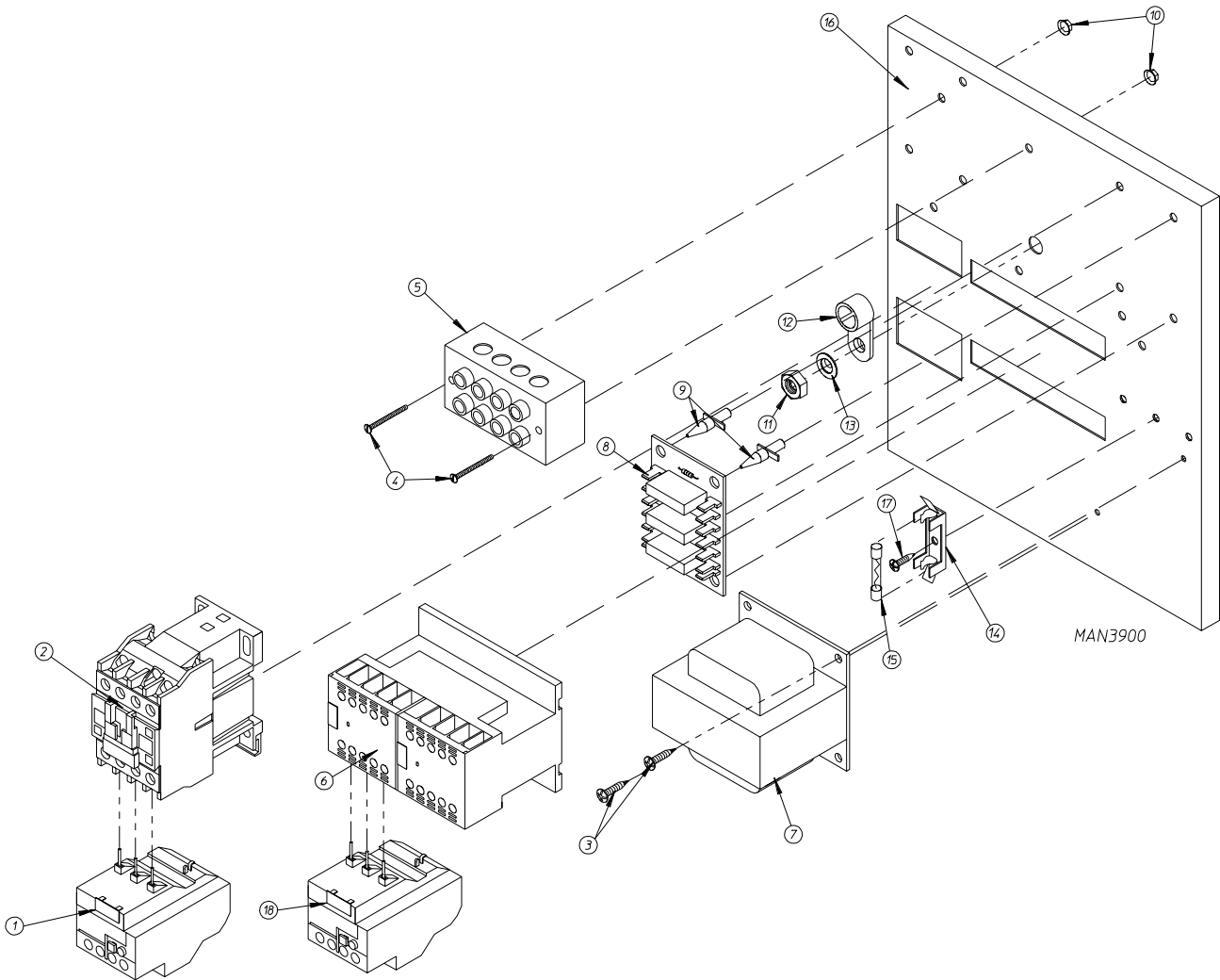

---

**For 208/230/240/380/416 Volt and Models ONLY**

<u>Illus. No.</u>	<u>Part No.</u>	<u>Qty.</u>	<u>Description</u>
1	132467	1	9 - 13 Amp Blower Overload <i>(for 208-230/240 volt models Only)</i>
	132468	1	4 - 6 Amp Blower Overload <i>(for 380/416 volt models Only)</i>
2	132445	1	12-Amp 3ø Contactor - 24 VAC
3	150300	2	#10 x 1/2" Hex Washer TEK Screw
4	150008	2	6-32 x 1-1/4" Phillips Round Head Machine Screw
5	120701	1	4-Position Terminal Block
6	132448	1	Reversing Contactor - 24 VAC
7	132070	1	208-230/240 Volt Transformer ONLY
	132082	1	380/416 Volt Transformer ONLY
	881763	1	ML Transformer Termination Kit
8	137060	1	Arc Suppressor (A.S.) Board
9	137013	4	Nylon Standoff
10	151000	2	#6-32 Pal Nut
11	152004	1	5/16-18 Hex Nut
12	121012	1	Ground Lug
13	153002	1	5/16" Lock Washer
14	136008	1	Fuse Holder ONLY
15	136057	1	1/2-Amp (Slo Blo) Fuse <i>(for 208-230/240 volt models Only)</i>
	136057	2	1/2-Amp (Slo Blo) Fuse <i>(for 380/416 volt models Only)</i>
16	881992	1	Reversing Relay Panel Assembly Complete (includes illus. nos. 1 through 18) <i>For 208 volt models ONLY</i>
	881991	1	Reversing Relay Panel Assembly Complete (includes illus. nos. 1 through 18) <i>For 230/240 volt models ONLY</i>
	881701	1	Reversing Relay Panel Assembly Complete (includes illus. nos. 1 through 18) <i>For 380/416 volt Models ONLY</i>
	323743	1	Relay Panel ONLY
17	150301	1	#8-18 x 7/16" Phillips Pan Head TEK Screw
18	132457	1	2.6 - 3.7-Amp Drive Motor Overload <i>(for 208 volt models Only)</i>
	132456	1	1.8 - 2.6-Amp Drive Motor Overload <i>(for 230/240 volt models Only)</i>
	132454	1	1.2 - 1.8-Amp Drive Motor Overload <i>For 380/416 volt - 50 Hz Models ONLY</i> <i>For 460 volt - 60 Hz Models ONLY</i>



As of September 12, 1997

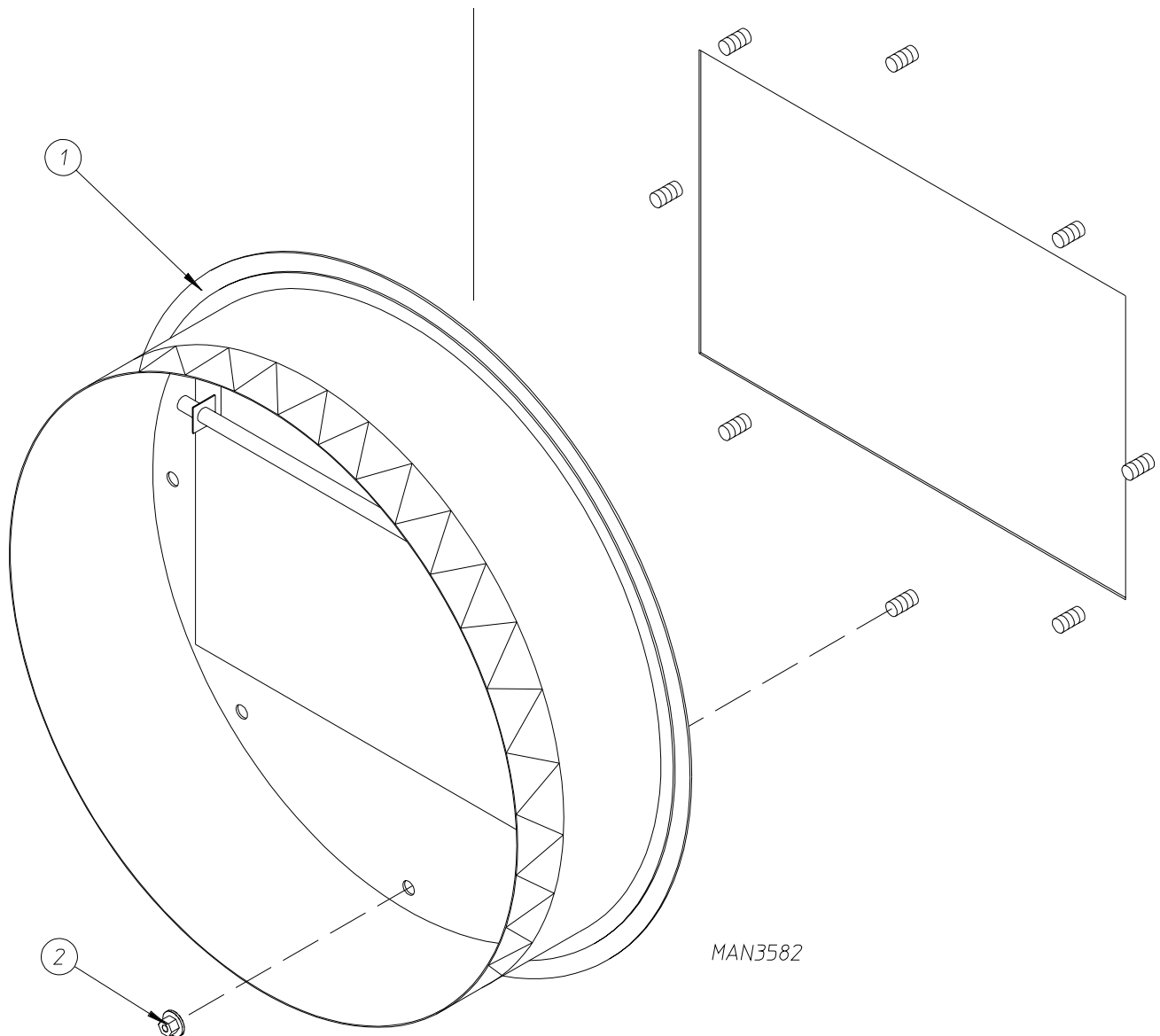

<u>Illus. No.</u>	<u>Part No.</u>	<u>Qty.</u>	<u>Description</u>
1	881705	1	White Transition Piece Assembly with Damper Complete
	881809	1	Blue Transition Piece Assembly with Damper Complete
2	152014	8	1/4-20 Free Spin Wash Nut

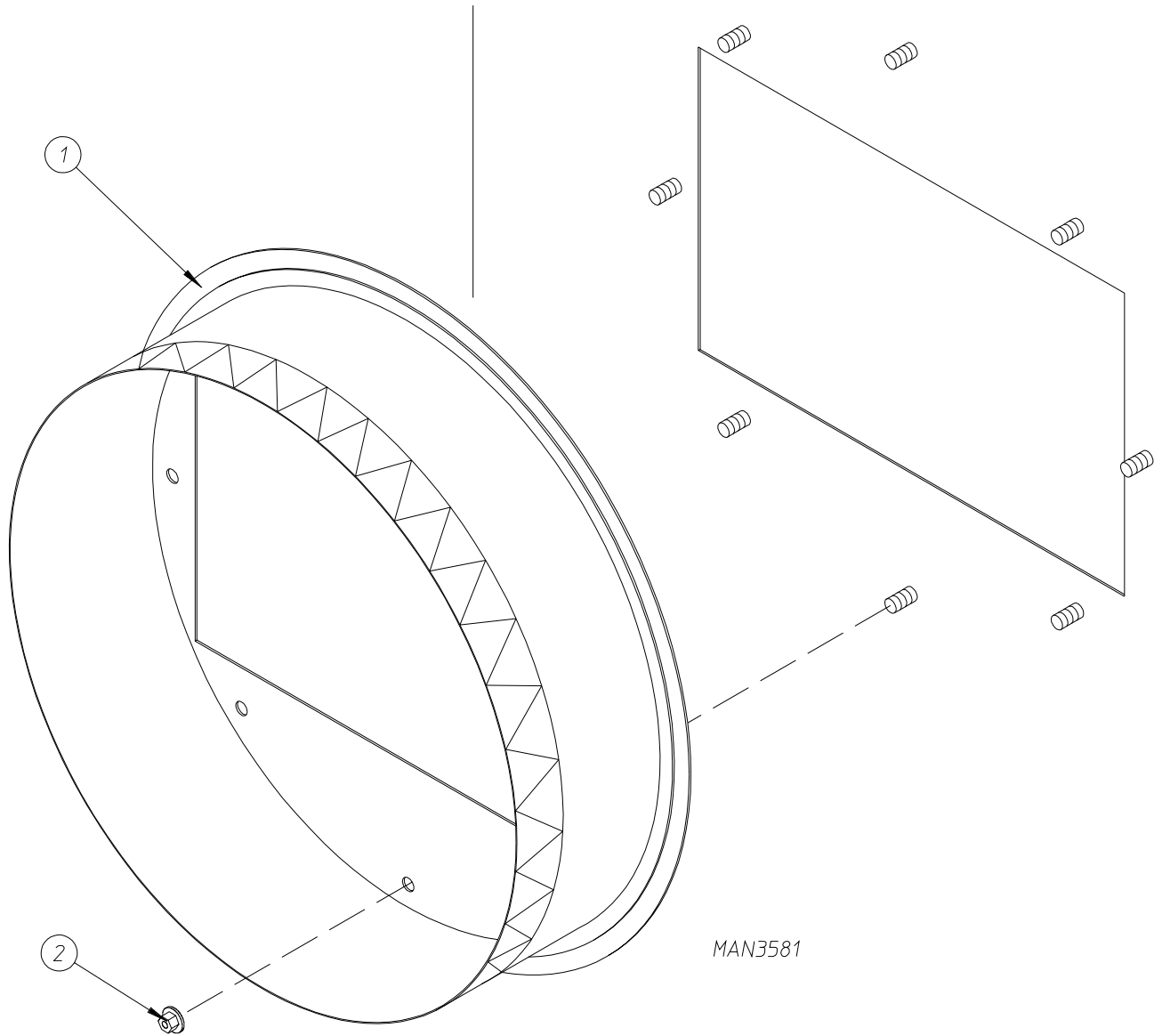

<u>Illus. No.</u>	<u>Part No.</u>	<u>Qty.</u>	<u>Description</u>
1	881704	1	White Exhaust Adapter Assembly <i>without</i> Damper
	881808	1	Blue Exhaust Adapter Assembly <i>without</i> Damper
2	152014	8	1/4-20 Free Spin Wash Nut



As of July 1, 1998

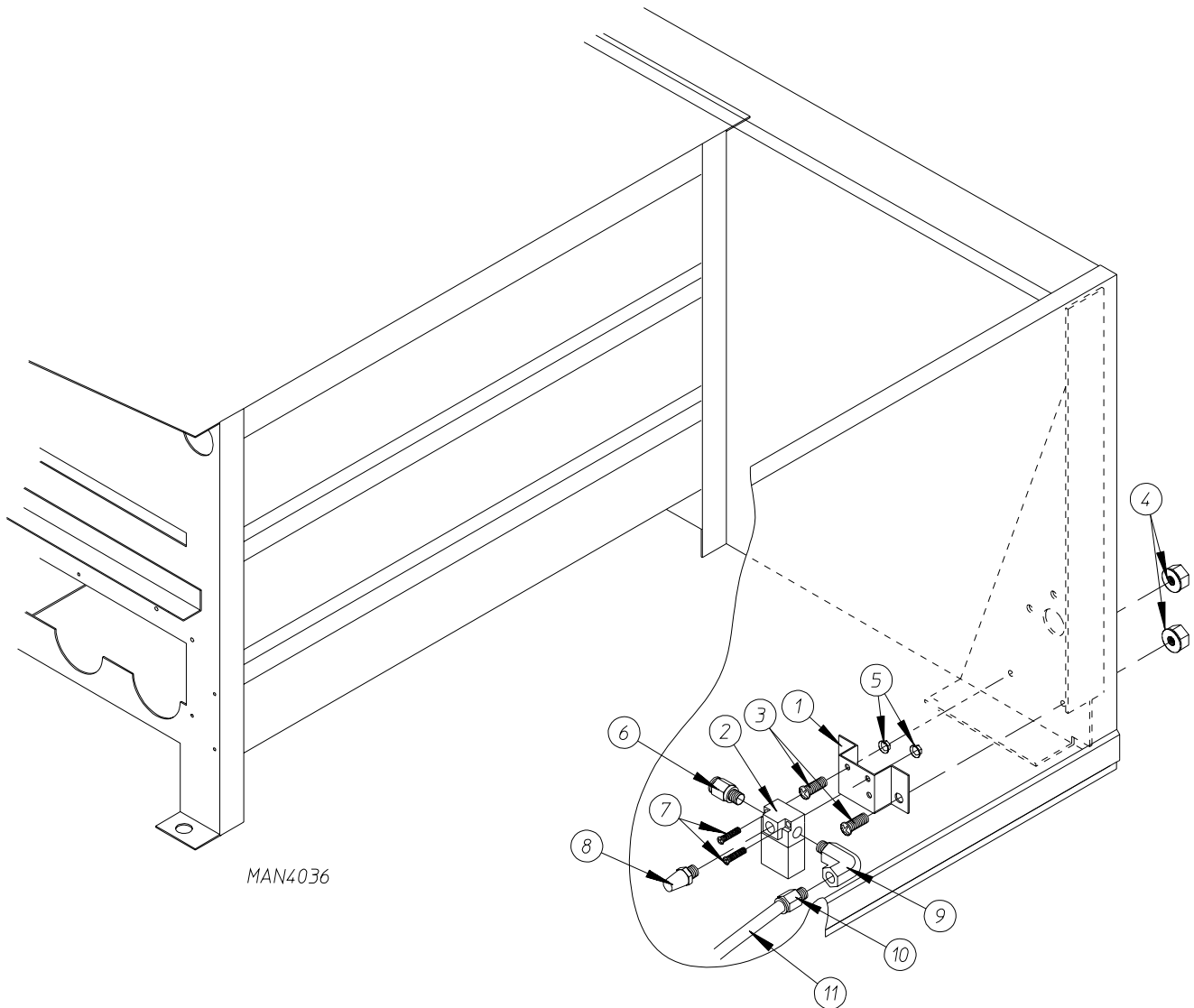

Illus. No.	Part No.	Qty.	Description
1	330987	1	Micro Valve Bracket
2	836002	1	Air Jet Solenoid
3	150111	2	1/4-20 Phillips Machine Screw
4	152014	2	1/4-20 Free Spin Wash Nut
5	151000	2	6-32 Pal Nut
6	100472	1	1/4" x 1/8" Male Connector
7	150002	2	6-32 x 1" Phillips Machine Screw
8	100520	1	1/8" NPT Silencer
9	143268	1	1/8" 90° Brass Straight Elbow
10	100472	1	1/4" x 1/8" Male Connector
11	143110	9'	1/4" Poly Flo Tubing

ADC450155    1- 12/16/97-50    2\* 01/15/98-50    3\* 05/21/98-50  
4\* 08/12/98-50    5\* 12/23/98-50

