



AD-115 Parts Manual 24 VAC Phase 5 1994 thru 1998

American Dryer Corporation

88 Currant Road

Fall River MA 02720-4781

Telephone: (508) 678-9010 / Fax: (508) 678-9447

E-mail: service@amdry.com

071594
071995
060297MFM/tf

ADC Part No. 450145

Retain This Manual In A Safe Place For Future Reference

American Dryer Corporation products embody advanced concepts in engineering, design, and safety. If this product is properly maintained, it will provide many years of safe, efficient, and trouble-free operation.

ONLY properly licensed technicians should service this equipment.

OBSERVE ALL SAFETY PRECAUTIONS displayed on the equipment or specified in the installation/operator's manual included with the dryer.

WARNING: UNDER NO CIRCUMSTANCES should the door switch or the heat circuit devices ever be disabled.

WARNING: The dryer *must never* be operated with any of the back guards, outer tops, or service panels removed. PERSONAL INJURY or FIRE COULD RESULT.

We have tried to make this manual as complete as possible and hope you will find it useful. ADC reserves the right to make changes from time to time, without notice or obligation, in prices, specifications, colors, and material, and to change or discontinue models.

Important

For your convenience, log the following information:

DATE OF PURCHASE _____ MODEL NO. **AD-115** _____
DISTRIBUTORS NAME _____
Serial Number(s) _____

Replacement parts can be obtained from your distributor or the ADC factory. When ordering replacement parts from the factory, you can FAX your order to ADC at (508) 678-9447 or telephone your orders directly to the ADC Parts Department at (508) 678-9010. Please specify the dryer **model number** and **serial number** in addition to the **description** and **part number**, so that your order is processed accurately and promptly.

The illustrations on the following pages may not depict your particular dryer exactly. The illustrations are a composite of the various dryer models. Be sure to check the descriptions of the parts thoroughly before ordering.

INSTRUCTIONS TO BE FOLLOWED IN THE EVENT THE USER SMELLS GAS MUST BE POSTED IN A PROMINENT LOCATION. THE INSTRUCTIONS TO BE POSTED SHALL BE OBTAINED FROM THE LOCAL GAS SUPPLIER.

Table of Contents

AD-115 Control Door Assembly	3
AD-115 Microprocessor Control Panel Assembly	4
AD-115 Control Box Assembly	5
AD-115 Dual Timer Control Panel Assembly	6, 7
AD-115 Dual Timer Control Box Assembly	8, 9
AD-115 Front Panel Main Door Assembly	10, 11
AD-115 Main Door Switch Assembly for models mfd. as of December 15, 1994	12
AD-115 Main Door Switch Assembly for models mfd. prior to December 15, 1994	13
AD-115 Lint Drawer/Lint Drawer Switch Box Assemblies for models mfd. as of March 28, 1995	14
AD-115 Lint Drawer/Lint Drawer Switch Box Assemblies for models mfd. prior to March 28, 1995	15
AD-115 Drop Lint Door Assembly	16
AD-115 Microprocessor Temperature Sensor Bracket Assembly	17
AD-115 Non-Microprocessor Temperature Sensor Bracket Assembly	18, 19
AD-115 Basket (Tumbler) / Support Assemblies	20, 21
AD-115 Tumbler Bearing Mount Assembly	22, 23
AD-115 Idler Bearing Mount Assembly	24, 25
AD-115 Totally Enclosed, Fan-Cooled Basket (Tumbler) Motor Mount Assembly	26, 27
ADG-115 Blower Motor Mount Assembly for Gas Models ONLY	28, 29
ADG-115 Blower Motor Mount Assembly for Electric Models ONLY	30, 31
ADG-115 Blower Motor Mount Assembly for Steam Models ONLY	32, 33
ADG-115 Direct Spark Ignition (DSI) Burner Assembly for Gas Models ONLY	34, 35
AD-115 Direct Spark Ignition (DSI) Module Mount Assembly	36
Sail Switch Assembly	37
AD-115 Electric Oven Assembly	38, 39
ADE-115 Electric Oven Relay Box Assembly 208/240 VAC - 50/60 Hz - 3Ø	40
ADE-115 Electric Oven Relay Box Assembly 380/416/480 VAC - 50/60 Hz - 3Ø	41
ADS-115 Steam Damper Assembly	42, 43
AD-115 Microprocessor Reversing Control Box Assembly for Gas and Steam Models, and for Electric Models mfd. prior to March 29, 1995	44
ADE-115 Microprocessor Reversing Contactor Mounting Panel Assembly for Electric Models mfd. as of March 29, 1995	45
AD-115 Dual Timer Reversing Control Box Assembly for Gas and Steam Models, and for Electric Models mfd. prior to March 29, 1995	46
ADE-115 Dual Timer Reversing Relay Mounting Panel Assembly for Electric Models mfd. as of March 29, 1995	47
AD-115 Extended Back Guard Assembly for ALL 60 Hz Models mfd. as of January 26, 1995 for ALL 50 Hz Models mfd. as of January 9, 1995	48
ADE-115 Back Guard Assembly for ALL 60 Hz Models mfd. prior to January 26, 1995 for ALL 50 Hz Models mfd. prior to January 9, 1995	49

AD-115 Step Down Transformer Usage Listing	50
ADE-115 Direct Spark Ignition (DSI) Burner Assembly Specifications	51
ADE-115 60 Kw Electric Oven Component Application Charts	52
ADE-115 72 Kw and 80 Kw Electric Oven Component Application Charts	53
ADE-115 Electric Oven Power Distribution	
for 60 Kw 208/240 VAC Microprocessor models mfd. as of April 11, 1995	54
ADE-115 Electric Oven Power Distribution	
for 60 Kw 380/416/480 VAC Microprocessor models mfd. as of April 11, 1995	55
ADE-115 Electric Oven Power Distribution	
for 60 Kw 208/240 VAC Dual Timer models mfd. as of April 11, 1995	56
ADE-115 Electric Oven Power Distribution	
for 60 Kw 380/416/480 VAC Dual Timer models mfd. as of April 11, 1995	57
ADE-115 Electric Oven Power Distribution	
for 60 Kw 208/240 VAC models mfd. prior to April 11, 1995	58
ADE-115 Electric Oven Power Distribution	
for 60 Kw 380/416/480 VAC models mfd. prior to April 11, 1995	59
ADE-115 Electric Oven Power Distribution	
for 72 Kw 208/240 VAC Microprocessor models mfd. as of April 11, 1995	60
ADE-115 Electric Oven Power Distribution	
for 72 Kw 600VAC Microprocessor	61
ADE-115 Electric Oven Power Distribution	
for 72 Kw 600 VAC Microprocessor models	62
ADE-115 Electric Oven Power Distribution	
for 72 Kw 380/416/480 VAC Microprocessor models mfd. as of April 11, 1995	63
ADE-115 Electric Oven Power Distribution	
for 72 Kw 208/240 VAC Dual Timer models mfd. as of April 11, 1995	64
ADE-115 Electric Oven Power Distribution	
for 72 Kw 380/416/480 VAC Dual Timer models mfd. as of April 11, 1995	65
ADE-115 Electric Oven Power Distribution	
for 72 Kw 208/240 VAC models mfd. prior to April 11, 1995	66
ADE-115 Electric Oven Power Distribution	
for 72 Kw 380/416/480 VAC models mfd. prior to April 11, 1995	67
ADE-115 Electric Oven Power Distribution	
for 80 Kw 208/240 VAC Microprocessor models mfd. as of April 11, 1995	68
ADE-115 Electric Oven Power Distribution	
for 80 Kw 380/416/480 VAC Microprocessor models mfd. as of April 11, 1995	69
ADE-115 Electric Oven Power Distribution	
for 80 Kw 208/240 VAC Dual Timer models mfd. as of April 11, 1995	70
ADE-115 Electric Oven Power Distribution	
for 80 Kw 380/416/480 VAC Dual Timer models mfd. as of April 11, 1995	71
ADE-115 Electric Oven Power Distribution	
for 80 Kw 208/240 VAC models mfd. prior to April 11, 1995	72
ADE-115 Electric Oven Power Distribution	
for 80 Kw 380/416/480 VAC models mfd. prior to April 11, 1995	73
ADE-115 Electric Oven Wiring	
for ALL 208/240 VAC models mfd. as of April 11, 1995	74
ADE-115 Electric Oven Wiring	
for ALL 380/416/480 VAC models mfd. as of April 11, 1995	75
ADE-115 Electric Oven Element Structure	
for 60 Kw 208/240 VAC models mfd. prior to April 11, 1995	76
ADE-115 Electric Oven Element Structure	
for 60 Kw 380/416/480 VAC models mfd. prior to April 11, 1995	77
Additional Parts Available	78

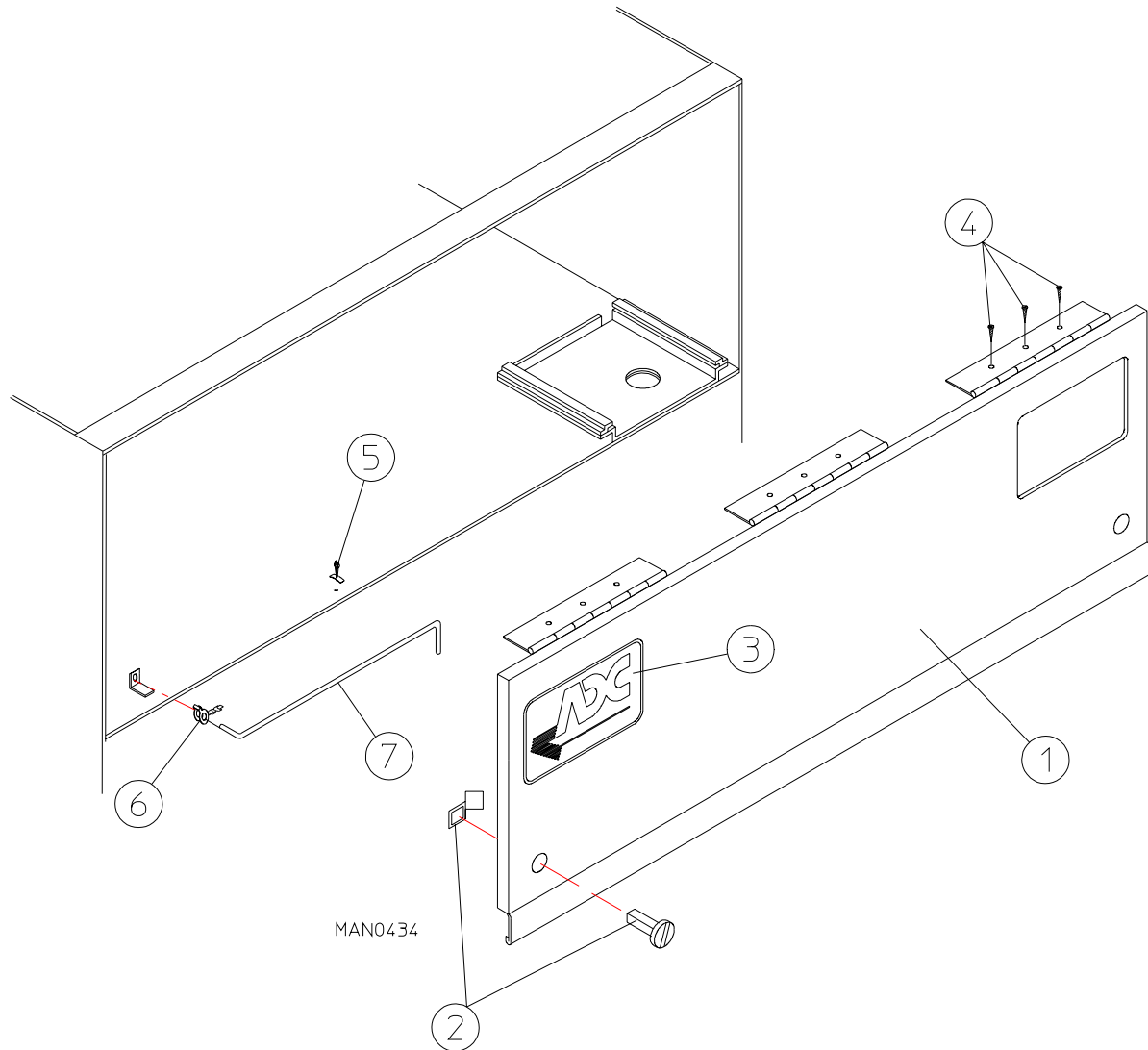

Illus. No.	Part No.	Qty.	Description
1	850491*	1	AD-115 Control Door Assembly ONLY (for Gas Models and Electric Models ONLY)
	850492	1	AD-115 Stainless Steel Control Door Assembly ONLY (for Gas Models and Electric Models ONLY)
	850489*	1	ADS-115 Short Control Door ONLY (for Steam Models ONLY)
	850490	1	ADS-115 Stainless Steel Short Control Door ONLY (for Steam Models ONLY)
2	160005	2	Spring Turn Latch (2-piece)
3	112360	1	ADC Logo ONLY
	870011	1	Logo Double Tape Kit
4	150309	9	#10-16 x 1/2" Hex Head TEK Crimptite Screw
5	102600	1	Control Door Support Rod Catch
6	102601	1	Control Door Rod Retainer Clip
7	102505	1	AD-115 Control Door Support Rod

* Specify color when ordering.

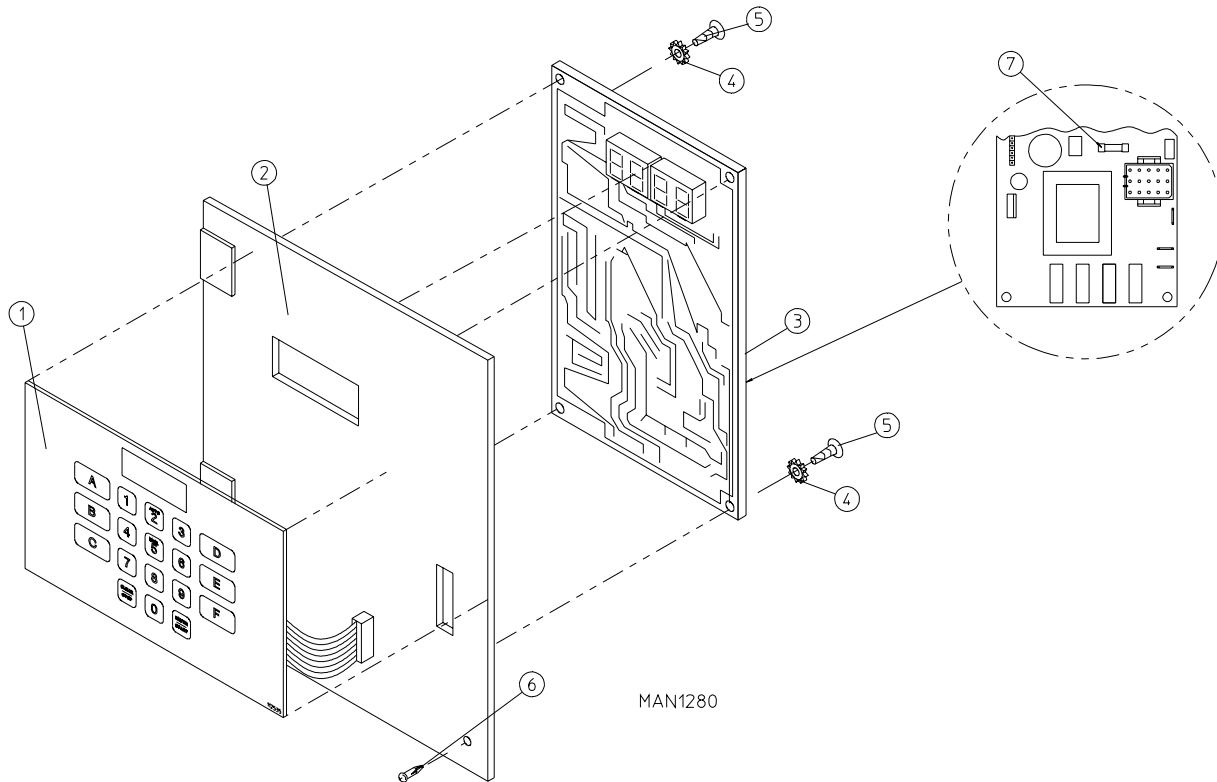

Illus. No.	Part No.	Qty.	Description
1	112535	1	OPL English Keyboard Label Assembly
	112276	1	OPL Stick-on Labels (English Only) ... Not Illustrated
	112275	1	OPL Stick-on Labels (Spanish, Italian, and Hebrew) ... Not Illustrated
	112277	1	3-Language OPL Stick-on Labels (English, Spanish, and Hebrew) ... Not Illustrated
	112278	1	5-Language OPL Stick-on Labels (Italian, Dutch, French, German, and Chinese) ... Not Illustrated
2	880836	1	AD-115 Microprocessor Control Panel ONLY
	801260	1	AD-115 Microprocessor Control Panel Only with Battery Bracket
	801215	1	AD-115 Microprocessor Control Panel Assembly Complete (includes illus. nos. 1 through 5 and 7)
	801214	1	AD-115 Microprocessor Control Panel Assembly Complete with Battery Option (includes illus. nos. 1 through 5 and 7)
3	137231	1	Phase 5 OPL Reversing Controller ONLY
	824998	1	Phase 5 Battery Clip
4	153010	2	#6 Star Washer
5	150005	2	#6-32 x 3/4" Phillips Round Head Machine Screw
6	150309	1	#10-16 x 1/2" Hex Head TEK Crimpite Screw (for models mfd. as of March 1, 1994)
	160005	1	Spring Turn Latch (2-piece) For models mfd. prior to March 1, 1994
7	136048	1	1/8-Amp (Slo Blo) Fuse ONLY

IMPORTANT: Check label on computer chip to verify correct part number for controller.

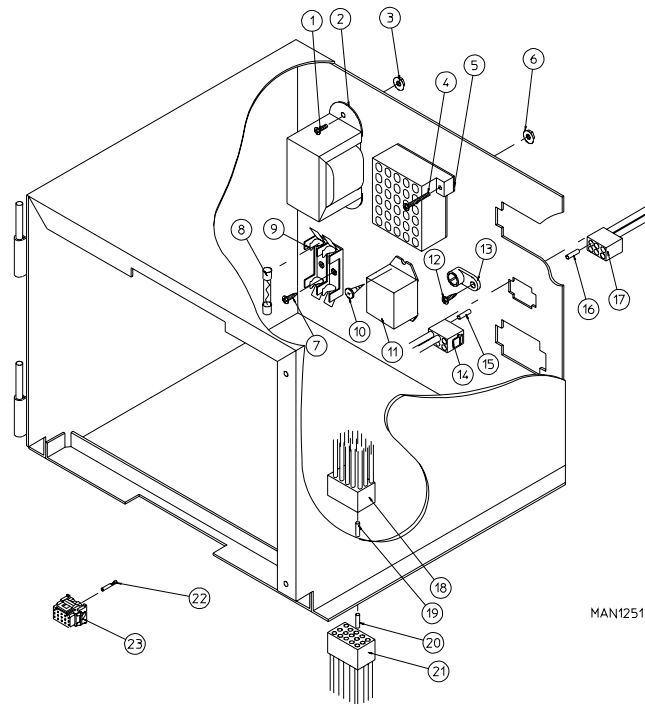

Illus. No.	Part No.	Qty.	Description
1	150100	2	#8-32 x 1/2" Round Head Machine Screw
2	141403	1	24 VAC Transformer - 50/60 Hz
3	151001	2	#8-32 Pal Nut
4	150002	2	#6-32 x 1" Round Head Machine Screw
5	120715	1	30-Position Terminal Block
6	151000	2	#6-32 Pal Nut
7	150102	2or3	#8 x 3/8" Phillips Pan Head TK Screw
8	136057	2	1/2-Amp (Slo Blo) Fuse ONLY
	182453	1	6-Amp Fuse (<i>for Electric Models ONLY</i>)
9	136008	2or3	Fuse Block/Strip ONLY
10	150309	2	#10-16 x 1/2" Hex Head TEK Crimptite Screw
11	131932	1	24 VAC Relay (<i>for Electric Models ONLY</i>)
12	150309	1	#10-16 x 1/2" Hex Head TEK Crimptite Screw
13	121010	1	L-70 Ground Lug
14	122631	1	6-Pin Connector ONLY
15	122705	*	Socket Terminal ONLY
16	122704	*	Pin Terminal ONLY
17	122630	1	6-Pin Connector ONLY
	137025	1	6/15 Position Strain Relief ... Not Illustrated
18	122625	1	15-Pin Connector ONLY
19	122704	12	Pin Terminal ONLY
20	122705	12	Socket Terminal ONLY
21	122626	1	15-Pin Socket Connector ONLY
22	122706	11	Microprocessor Socket ONLY
23	122641	1	15-Pin Microprocessor Connector ONLY
--	122800	1	Microprocessor (female) Pin Extraction Tool
--	122801	1	Pin/Socket Extraction Tool

* As required (either 2 or 3).

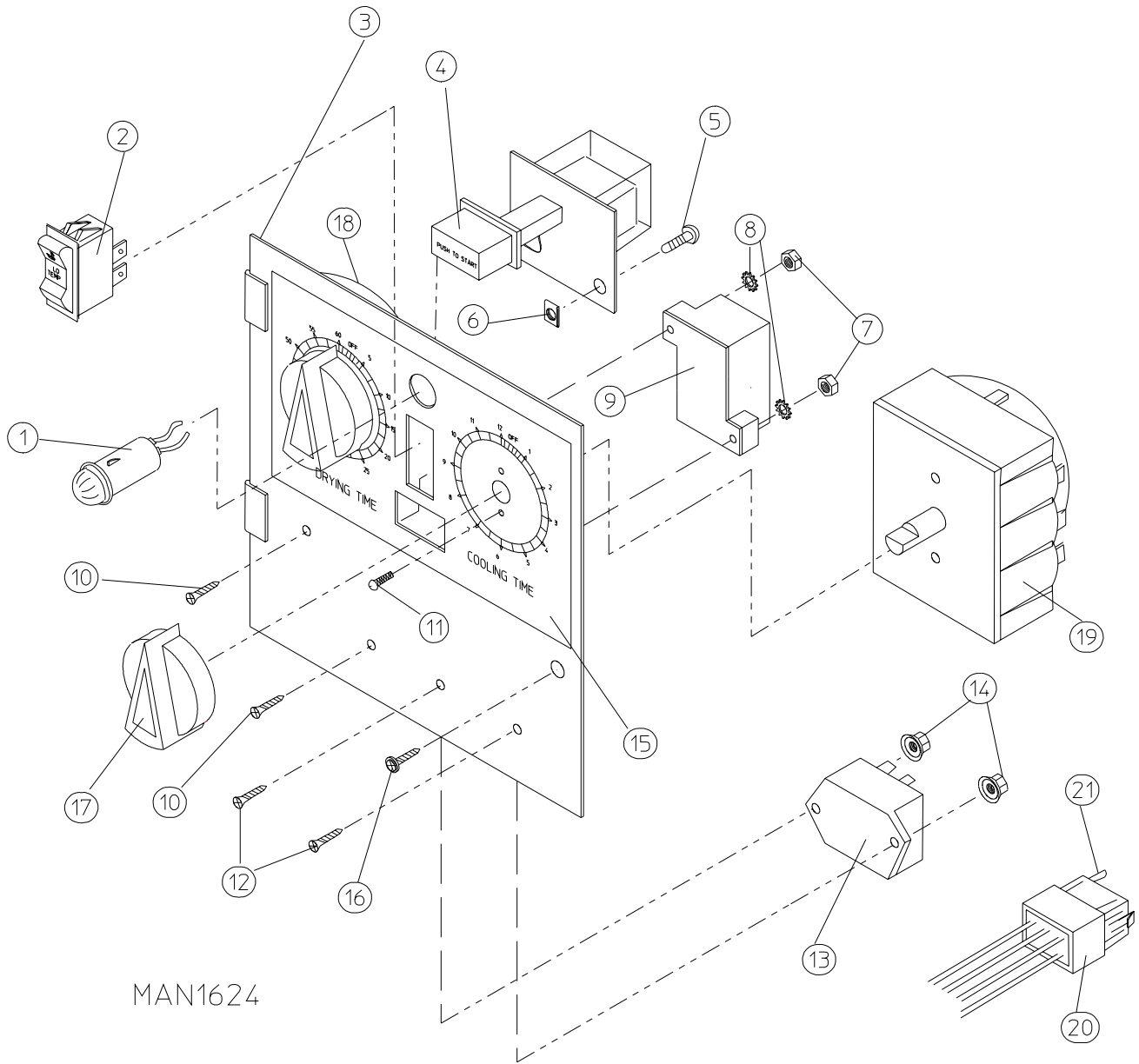

MAN1624

Illus. No.	Part No.	Qty.	Description
1	123005	1	Red Indicator Light - 24 VAC
2	122400	1	Rocker Heat Selector Switch
3	880838	1	AD-115 Dual Timer Control Panel Assembly Complete - 24 VAC (includes illus. nos. 1 through 15 and 17 through 21)
	880837	1	AD-115 Dual Timer Control Panel ONLY
4	131917	1	Push to Start Relay -24 VAC
5	150207	2	#10-24 x 1/2" Round Head Machine Screw
6	154001	2	#10-24 Speed Nut
7	152000	2	#6-32 Hex Nut
8	153010	2	#6 Star Washer
9	120730	1	30-Position Terminal Block (for models mfd. as of May 2, 1993)
	120713	1	18-Position Terminal Block (for models mfd. prior to May 2, 1993)
10	153565	2	#6-32 x 1" Clinch Stud
11	150110	4	#8-32 x 1/4" Phillips Round Head Machine Screw
12	153560	2	#6-32 x 1/2" Clinch Stud
13	131931	1	Dual Timer Relay - 24 VAC
14	151000	2	#6-32 Pal Nut
15	112050	1	Dual Timer Label ONLY
16	150309	1	#10-16 x 1/2" Hex Head TEK Crimptite Screw (for models mfd. as of March 1, 1994)
	160005	1	Spring Turn Latch (2-piece) For models mfd. prior to March 1, 1994
17	124103	2	Arrow Timer Knob
18	124025	1	60 Minute Timer - 24 VAC
19	124030	1	15 Minute Timer - 24 VAC
20	122602	1	9-Pin Connector ONLY
21	122700	7	Pin Terminal ONLY
--	122801	1	Pin/Socket Extraction Tool

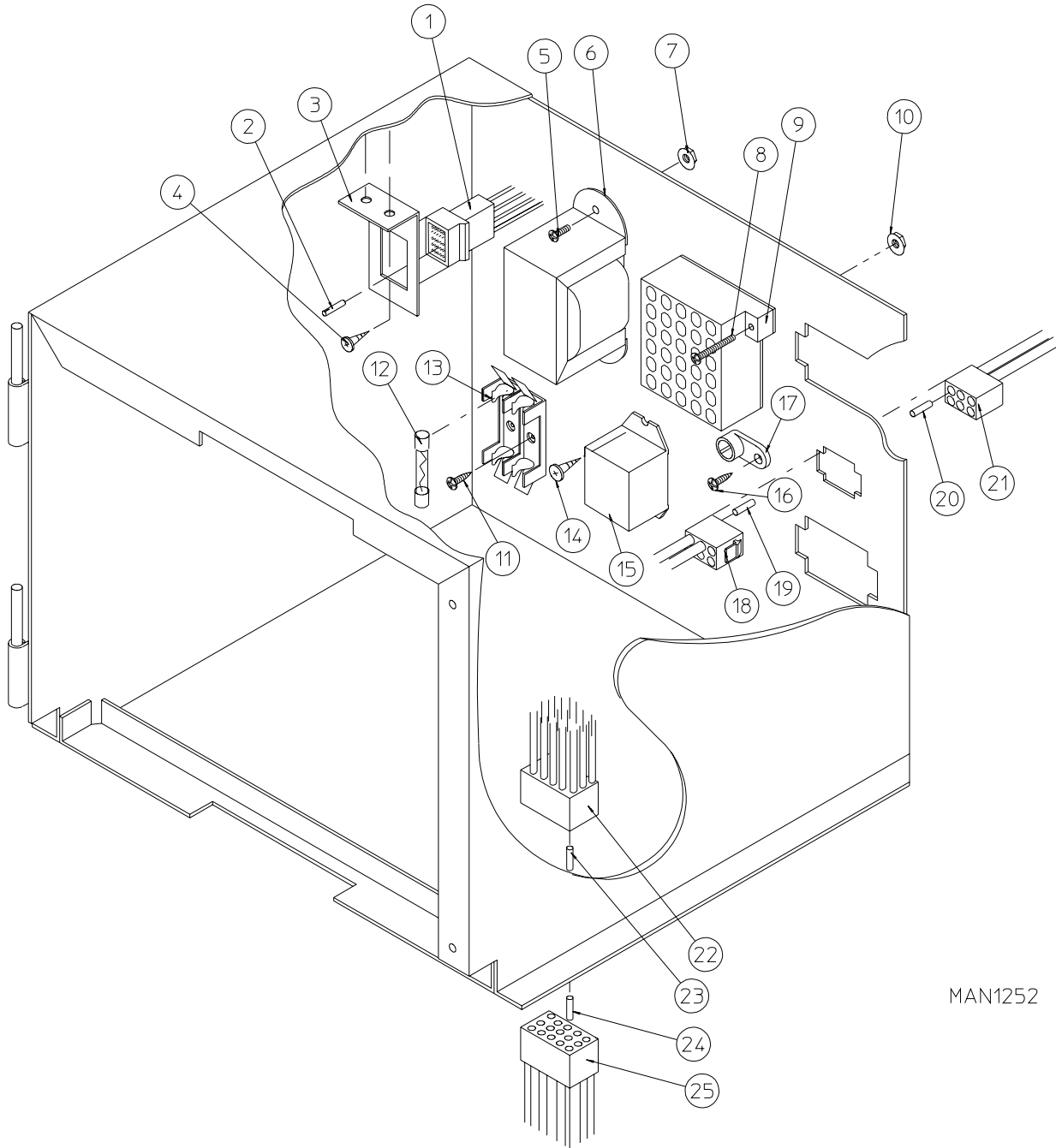

MAN1252

Illus. No.	Part No.	Qty.	Description
1	122603	1	9-Pin Socket Connector
2	122701	7	Socket Terminal ONLY
	122801	1	Pin/Socket Extraction Tool
3	315010	1	9-Pin Connector Bracket
4	150300	2	#10 x 1/2" Hex Washer TEK Screw
5	150100	2	#8-32 x 1/2" Round Head Machine Screw
6	141403	1	24 VAC Transformer - 50/60 Hz
7	151001	2	#8-32 Pal Nut
8	150002	2	#6-32 x 1" Round Head Machine Screw
9	120715	1	30-Position Terminal Block
10	151000	2	#6-32 Pal Nut
11	150301	2or3	#8-18 x 7/16" Phillips Pan Head TEK Screw
12	136057	2	1/2-Amp (Slo Blo) Fuse ONLY
	182453	1	6-Amp Fuse (for Electric Models ONLY)
13	136008	2or3	Fuse Block/Strip
14	150309	2	#10-16 x 1/2" Hex Head TEK Crimptite Screw
15	131932	1	24 VAC Relay (for Electric Models ONLY)
16	150309	1	#10-16 x 1/2" Hex Head TEK Crimptite Screw
17	121010	1	L-70 Ground Lug
18	122631	1	6-Pin Socket Connector ONLY
19	122705	2	Socket Terminal ONLY
20	122704	2	Pin Terminal ONLY
21	122630	1	6-Pin Connector ONLY
	137025	1	6/15 Position Strain Relief ... Not Illustrated
22	122625	1	15-Pin Connector ONLY
23	122704	10	Pin Terminal ONLY
24	122705	10	Socket Terminal ONLY
25	122626	1	15-Pin Socket Connector ONLY
--	122801	1	Pin/Socket Extraction Tool

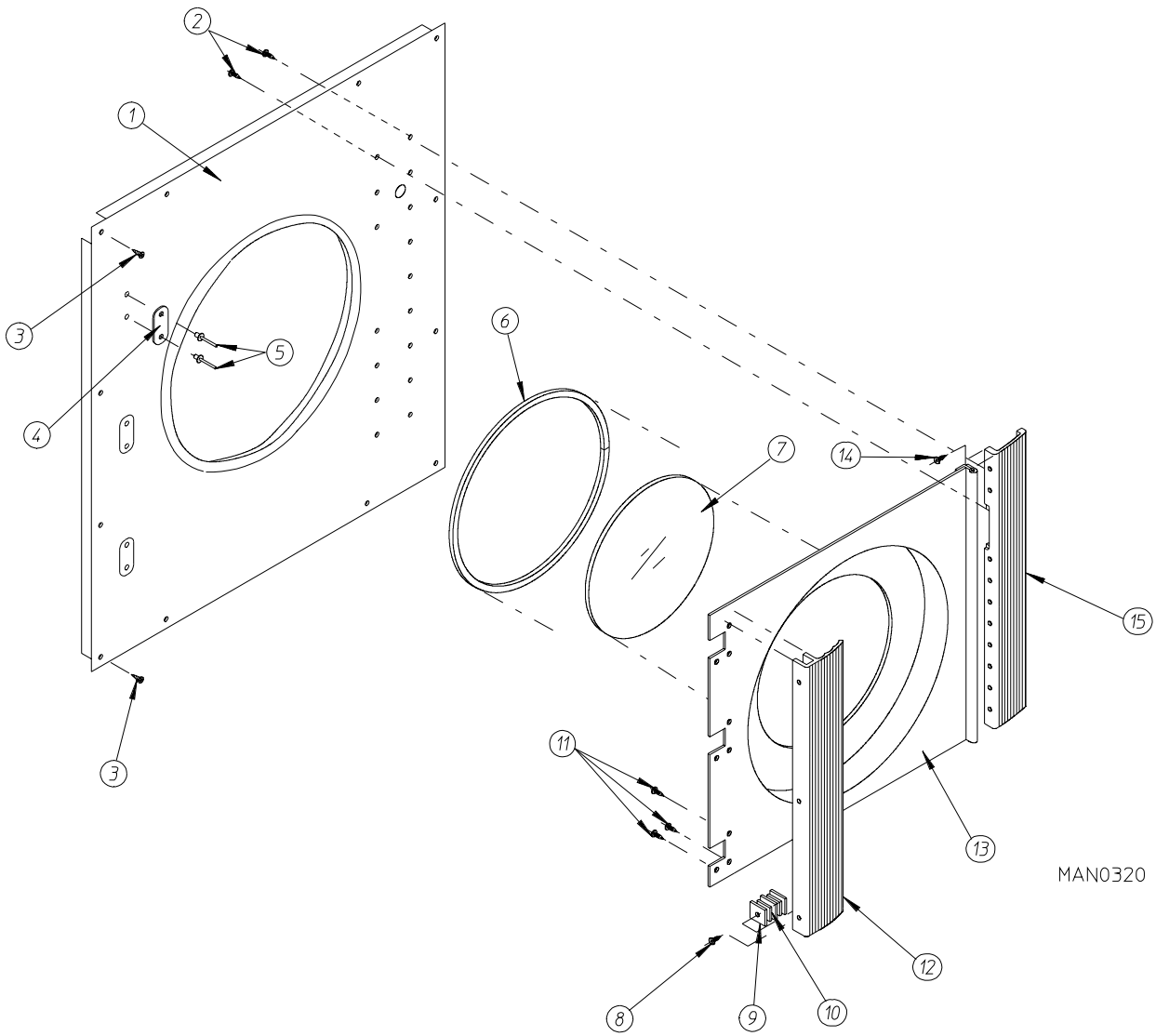

Illus. No.	Part No.	Qty.	Description
1	800349*	1	AD-115 Right Hand Front Panel Assembly (includes illus. nos. 1, 4, and 5)
	850751	1	AD-115 Stainless Steel Right Hand Front Panel Assembly (includes illus. nos. 1, 4, and 5)
2	150309	15	#10-16 x 1/2" Hex Head TEK Crimptite Screw
3	150412	12	#10-16 x 3/4" Phillips Round Head Crimptite Screw
4	170340	3	3-1/2" Stainless Steel Striker Pad
5	154200	6	5/32" Pop Rivet
6	102308	1	AD-115 Door Gasket ONLY (94" length)
7	102210	1	20-7/16" Door Glass ONLY
	170730	1	Glass Adhesive (10.3 oz. cartridge)
8	150401	3	#10-24 x 1-1/4" Phillips Taptite Screw
9	306801	6	Magnet Keeper ONLY
10	102100	6	1" x 1" x 1/4" Main Door Magnet ONLY
11	150309	9	#10-16 x 1/2" Hex Head TEK Crimptite Screw
12	180151	1	35" Granite Main Door Handle ONLY
13	800265*	1	AD-115 Main Door Assembly Complete with Granite Handle (includes illus. nos. 6 through 13)
	800266	1	AD-115 Stainless Steel Main Door Assembly Complete with Granite Handle (includes illus. nos. 6 through 13)
	800122*	1	AD-115 Main Door Assembly with Glass Gasket ONLY (includes illus. nos. 6, 7, and 13)
	800123	1	AD-115 Stainless Steel Main Door Assembly with Glass Gasket ONLY (includes illus. nos. 6, 7, and 13)
14	150430	10	#10 x 1/2" Phillips Self Drilling Screw
15	180156	1	35" Granite Main Door Hinge Block ONLY

* Specify color when ordering.

for models mfd. as of December 15, 1994

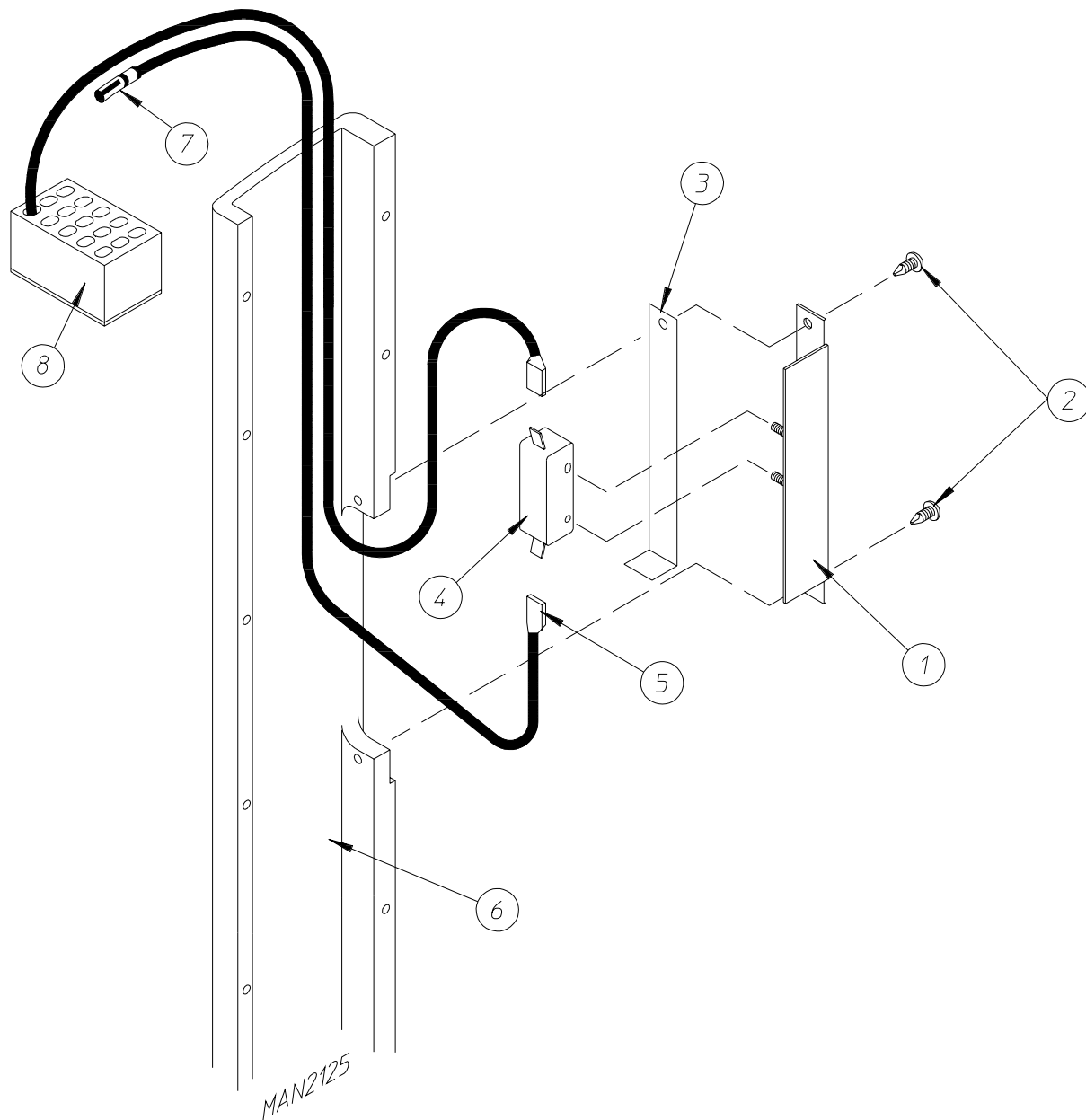

Illus. No.	Part No.	Qty.	Description
1	821098	1	AD-115 Main Door Switch Assembly Complete (includes illus. nos. 1 through 4 and 6)
	821097	1	Main Door Switch Bracket Assembly ONLY
	102405	1	Main Door Switch Actuator ONLY
2	150309	2	#10-16 x 1/2" Hex Head TEK Crimptite Screw
3	102405	1	Main Door Switch Actuator
4	137005	1	Main Door Switch ONLY
5	121028	2	1/4" x .032 Insulated Terminal ONLY
6	180156	1	35" Granite Main Door Hinge Block ONLY
7	122705	2	Socket Mate to Split Pin
8	122626	1	15-Pin Cap Housing ONLY (M/L)

for models mfd. prior to December 15, 1994

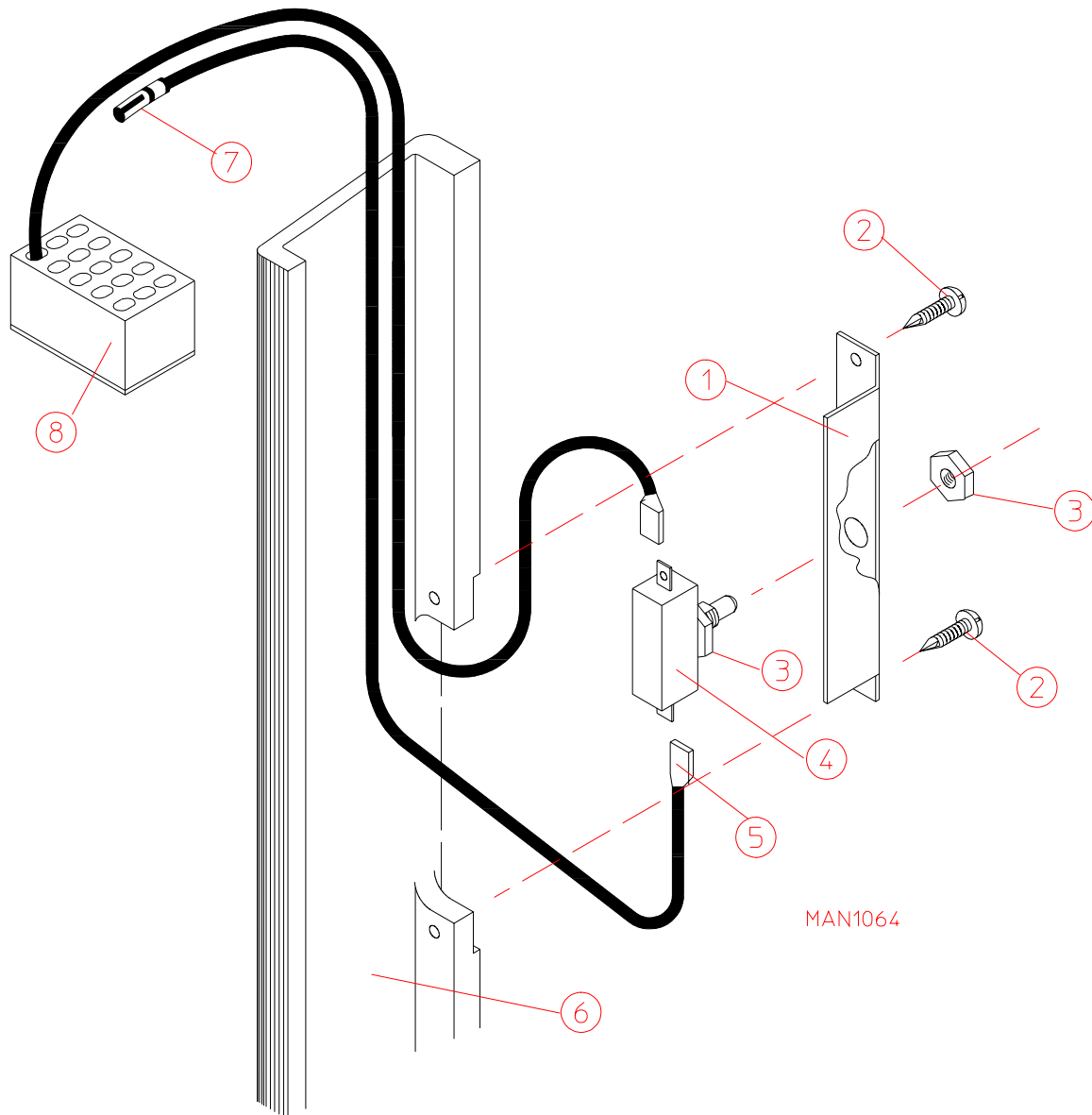

Illus. No.	Part No.	Qty.	Description
1	313208	1	Main Door Switch Bracket ONLY
2	150309	2	#10-16 x 1/2" Hex Head TEK Crimptite Screw
3	152003	2	3/8-32 x 1/2" x 1/16" Door Switch Nut
4	136995	1	Door Switch ONLY
			(for models mfd. as of June 26, 1992)
	137006	1	Door Switch ONLY
			(for models mfd. prior to June 26, 1992)
5	121028	2	1/4" x .032 Insulated Terminal ONLY
6	180156	1	35" Granite Main Door Hinge Block ONLY
			(for models mfd. as of March 8, 1993)
	180155	1	35" Gray Main Door Hinge Block ONLY
			(models mfd. prior to March 8, 1993)
7	122705	2	Socket Mate to Split Pin
8	122626	1	15-Pin Cap Housing ONLY (M/L)

for models mfd. as of March 28, 1995

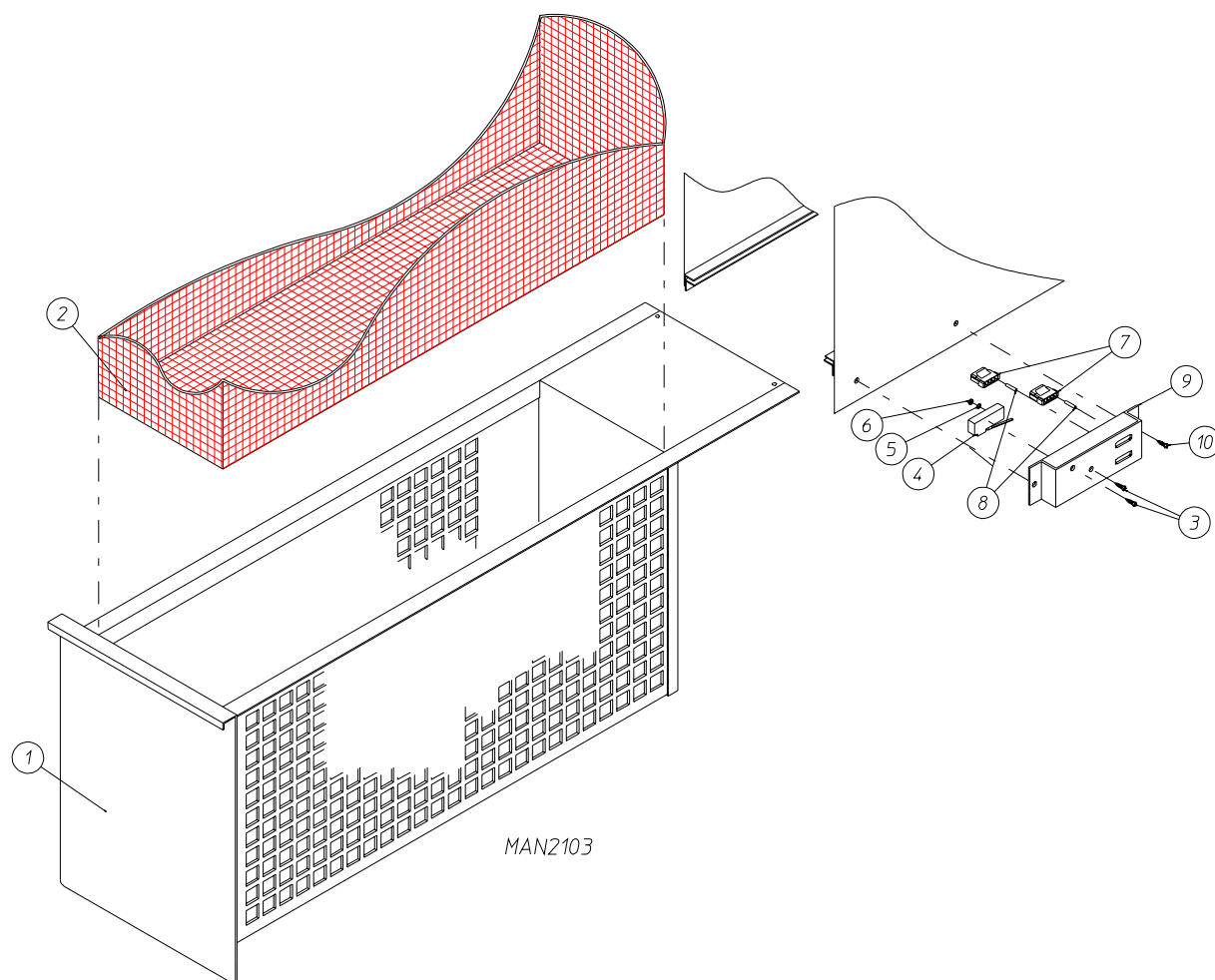

Illus. No.	Part No.	Qty.	Description
1	850597*	1	AD-115 Lint Drawer Assembly with Safety Switch Acatuator Complete
	850598	1	AD-115 Stainless Steel Lint Drawer Assembly with Safety Switch Actuator Complete
2	820017	1	AD-115 Lint Screen Assembly ONLY
3	153562	2	#8-32 x 3/4" Clinch Stud
4	821119	1	Lint Drawer Switch Assembly Complete (includes illus. nos. 3 through 9)
	821116	1	Lint Drawer Switch Mounting Bracket Assembly ONLY (includes illus. no. 3 and 4)
	332348	1	Lint Drawer Switch Mounting Bracket ONLY
5	136992	1	AD-115 Lint Drawer Switch ONLY
6	153000	2	#8 Steel Burr
7	152001	2	#8-32 Hex Nut
8	122605	2	4-Pin Socket Connector ONLY
9	122701	4	Socket Terminal ONLY
	122801	1	Pin/Socket Extraction Tool
10	150309	2	#10-16 x 1/2" Hex Head TEK Crimptite Screw

* Specify color when ordering.

for models mfd. prior to March 28, 1995

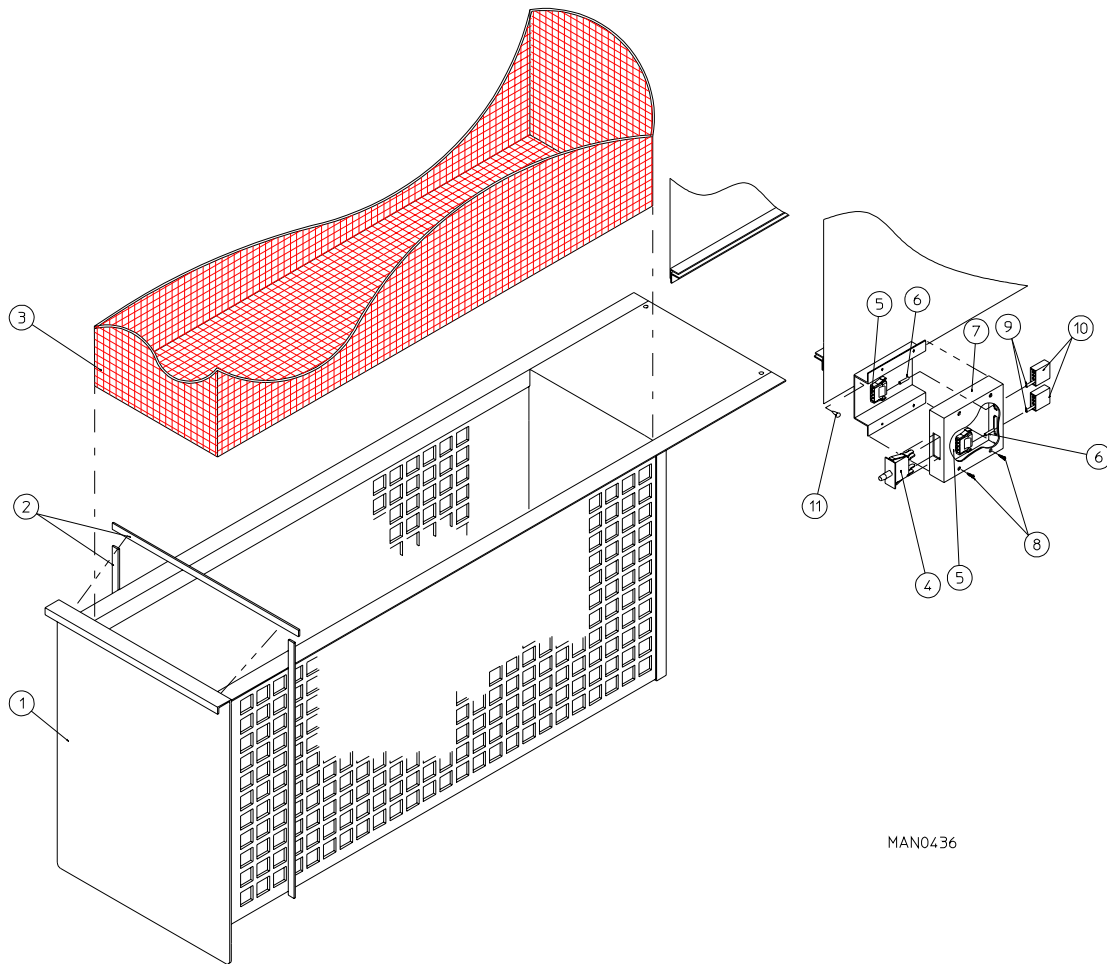

MAN0436

Illus. No.	Part No.	Qty.	Description
1*	880871	1	AD-115 Lint Drawer Assembly Complete (includes illus. nos. 1 and 2)
2	117602	5	Gasket (sold in feet)
3	820017	1	AD-115 Lint Screen Assembly ONLY
4	122116	1	Lint Drawer Switch ONLY
5	122605	2	4-Pin Socket Connector ONLY
6	122701	4	Socket Terminal ONLY
	122801	1	Pin/Socket Extraction Tool
7	800264	1	Lint Drawer Switch Box Assembly Complete (includes illus. nos. 4 through 7)
	304034	1	Lint Drawer Switch Box ONLY
8	150301	2	#8-18 x 7/16" Phillips Pan Head TEK Screw
9	122700	4	Pin Terminal ONLY
10	122604	2	4-Pin Connector ONLY
11	150301	2	#8-18 x 7/16" Phillips Pan Head TEK Screw

* Specify color when ordering.

NOTE: Gasket used on models mfd. prior to December 1, 1994. For current gasket placement refer to AD-115 Drop Lint Door Assembly on **page 16**.

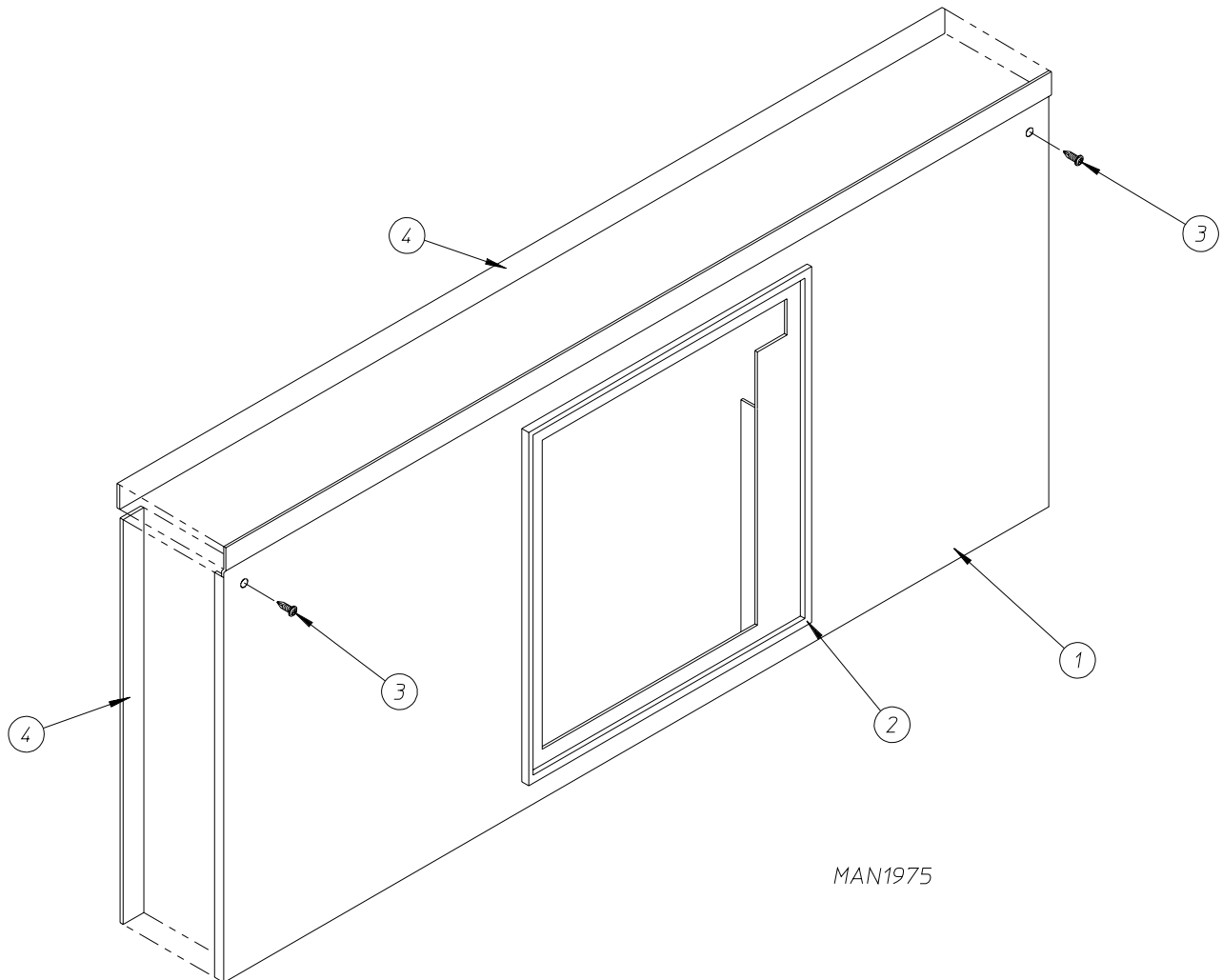

Illus. No.	Part No.	Qty.	Description
1	880870*	1	AD-115 Drop Lint Door Assembly (includes illus. nos. 1, 2, and 4)
	880872	1	AD-115 Stainless Steel Drop Lint Door Assembly (includes illus. nos. 1, 2, and 4)
2	117602	5	Gasket (sold in feet)
3	150309	5	#10-16 x 1/2" Hex Head TEK Crimptite Screw
4	117600	5	Noise Suppressor Tape (sold in feet)

* Specify color when ordering.

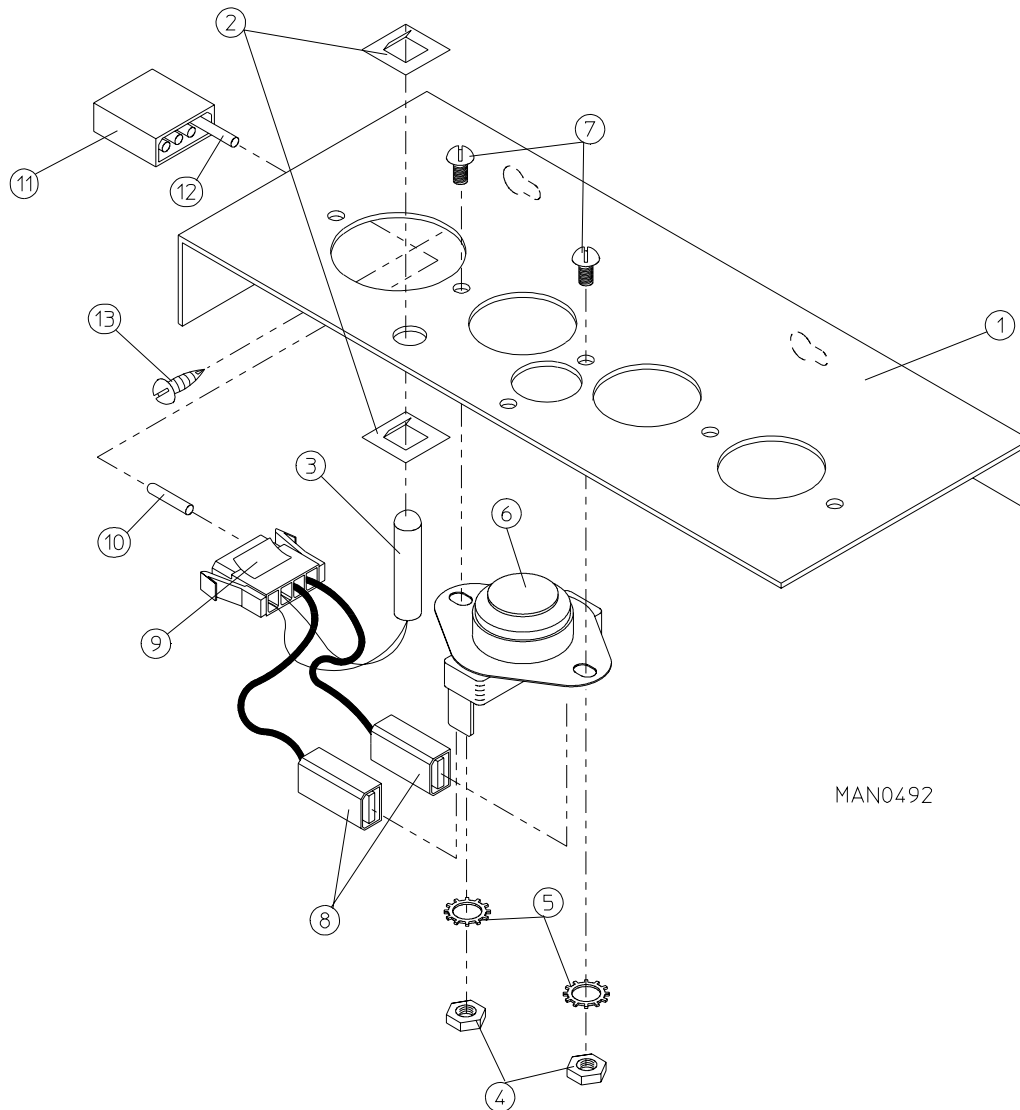

Illus. No.	Part No.	Qty.	Description
1	820022	1	AD-115 Temperature Sensor Bracket Assembly Complete (includes illus. nos. 1 through 10)
	331295	1	AD-115 Temperature Sensor Bracket ONLY
2	154007	2	1/4" Tinnerman Push-On Fastener
3	880251	1	1/4" Temperature Sensor Probe Assembly (includes illus. nos. 2, 3, 8, 9, and 10)
4	152000	2	#6-32 Hex Nut
5	153010	2	#6 Star Washer
6	130112	1	225° Large Automatic Reset Thermostat ONLY
7	150005	2	#6-32 x 1/4" Round Head Machine Screw
8	121028	2	Insulated Terminal ONLY
9	122605	1	4-Pin Socket Connector ONLY
10	122701	4	Socket Terminal ONLY
11	122604	1	4-Pin Connector ONLY
12	122700	4	Pin Terminal ONLY
	122801	1	Pin/Socket Extraction Tool
13	150301	2	#8-18 x 7/16" Phillips Pan Head TEK Screw

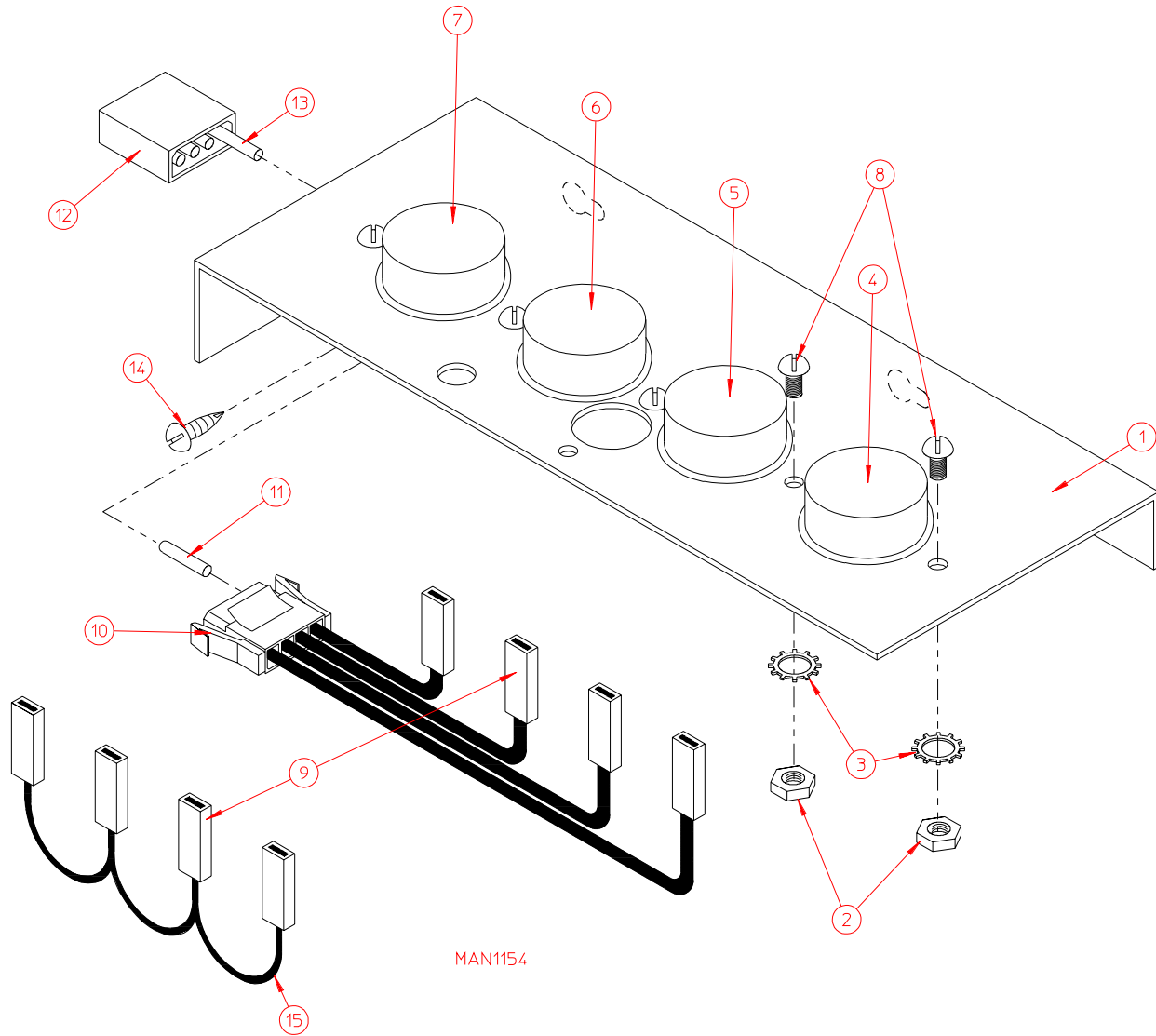

Illus. No.	Part No.	Qty.	Description
1	801404	1	AD-115 Non-Microprocessor Sensor Bracket Assembly Complete (includes illus. nos. 1 through 11 and 15) For Gas and Electric Models ONLY
	880839	1	ADS-115 Non-Microprocessor Sensor Bracket Assembly Complete (includes illus. nos. 1 through 11 and 15) For Steam Models ONLY
	331295	1	Universal Sensor Bracket ONLY
2	152000	5	#6-32 Hex Nut
3	153010	5	#6 Star Washer
4	130101	1	180° Large Thermostat (for Gas and Electric Models ONLY)
	130104	1	215° Large Thermostat (for Steam Models ONLY)
5	130109	1	140° Large Thermostat (for Gas and Electric Models ONLY)
	130100	1	150° Large Thermostat (for Steam Models ONLY)
6	130107	1	160° Large Thermostat (for Gas and Electric Models ONLY)
	130101	1	180° Large Thermostat (for Steam Models ONLY)
7	130112	1	225° Large Thermostat (for ALL models)
8	150005	5	#6-32 x 1/4" Round Head Machine Screw
9	121028	8	Insulated Terminal ONLY
10	122605	1	4-Pin Socket (female) Connector ONLY
	840062	1	Sensor (4) Bracket Harness Assembly (includes illus. nos. 9, 10, and 11)
11	122701	4	Socket Terminal ONLY
12	122604	1	4-Pin Connector ONLY
13	122700	4	Pin Terminal ONLY
	122801	1	Pin/Socket Extraction Tool
14	150301	2	#8-18 x 7/16" Phillips Pan Head TEK Screw
15	831701	1	AD-115 Sensor Jumper (4) ONLY

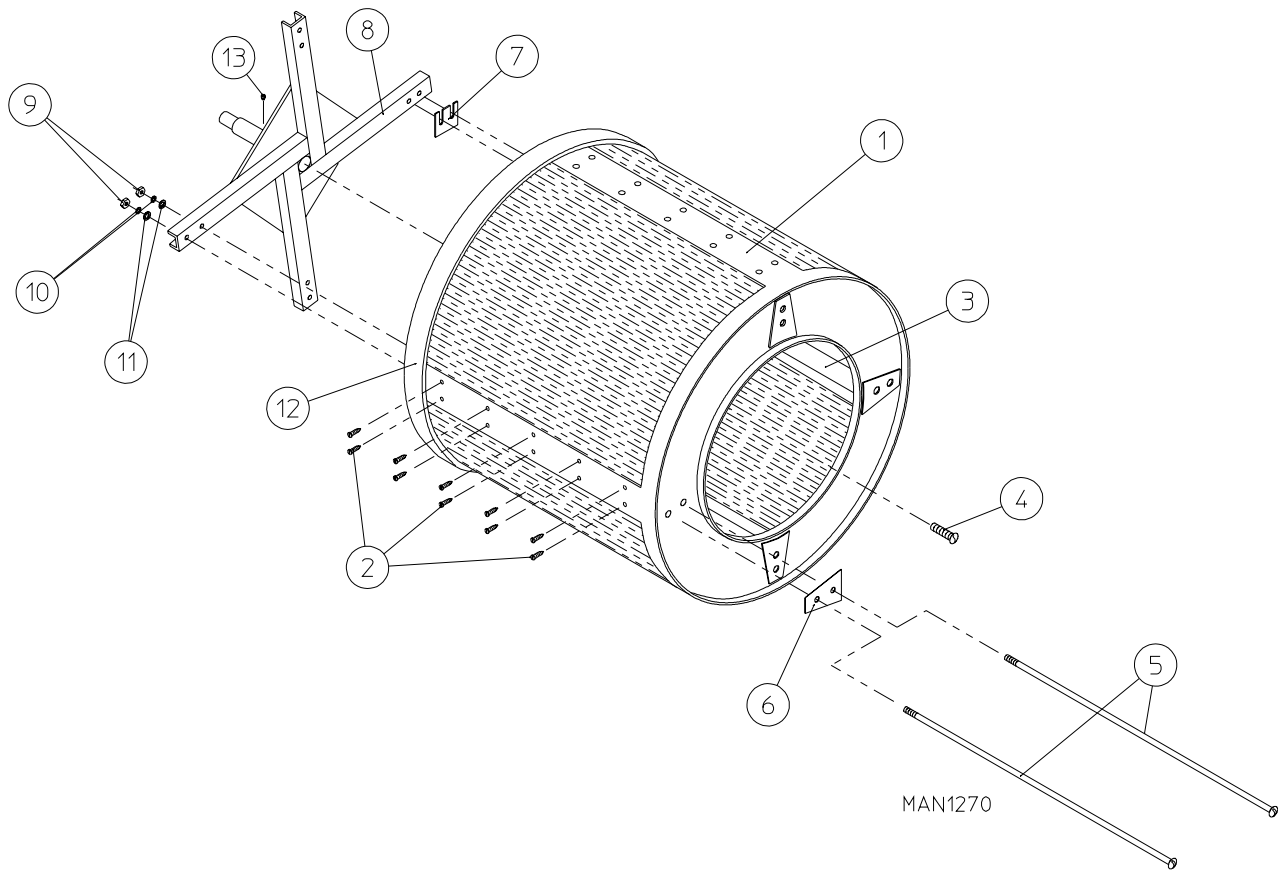

Illus. No.	Part No.	Qty.	Description
1	800707*	1	AD-115 Basket ONLY
	800858*	1	AD-115 Stainless Steel Basket ONLY
	800807	1	AD-115 Basket and Support Assembly Complete (includes illus. nos. 1 through 12)
	820054**	1	AD-115 Basket and Support Assembly Complete (includes illus. nos. 1 through 12) For Models with Rotation Sensor ONLY
	800868	1	AD-115 Stainless Steel Basket and Support Assembly Complete (includes illus. nos. 1 through 12)
	820053**	1	AD-115 Stainless Steel Basket and Support Assembly Complete (includes illus. nos. 1 through 12) For models with Rotation Sensor ONLY
2	150309	40	#10-16 x 1/2" Hex Head TEK Crimptite Screw
3	301300	4	AD-115 Basket Rib ONLY
	301400	4	AD-115 Stainless Steel Basket Rib ONLY
4	150500	1	5/16-18 x 3/4" Socket Button Head Screw
5	100909	8	1/2-13 x 43" Tie Rod
6	301700	4	Basket Reinforcing Plate ONLY
7	301701	***	AD-115 Basket Shim ONLY
8	800607	1	AD-115 Basket Support ONLY
	880821	1	AD-115 Basket Support ONLY (for models with Rotation Sensor ONLY)
9	152011	8	1/2-13 Hex Nut
10	153026	16	1/2" Lock Washer
11	153014	8	7/16" Flat Washer
12	116004	1	Felt Collar ONLY
--	401010	1	#847 Adhesive for Felt Collar
13	821002	1	Rotation Magnet Holder Assembly (for microprocessor models with optional Rotation Sensor)

* Felt collar not included and must be ordered separately.

** Rotation Sensor Magnet Holder Assembly (Illus. no. 13) **must be** purchased separately.

*** As required.

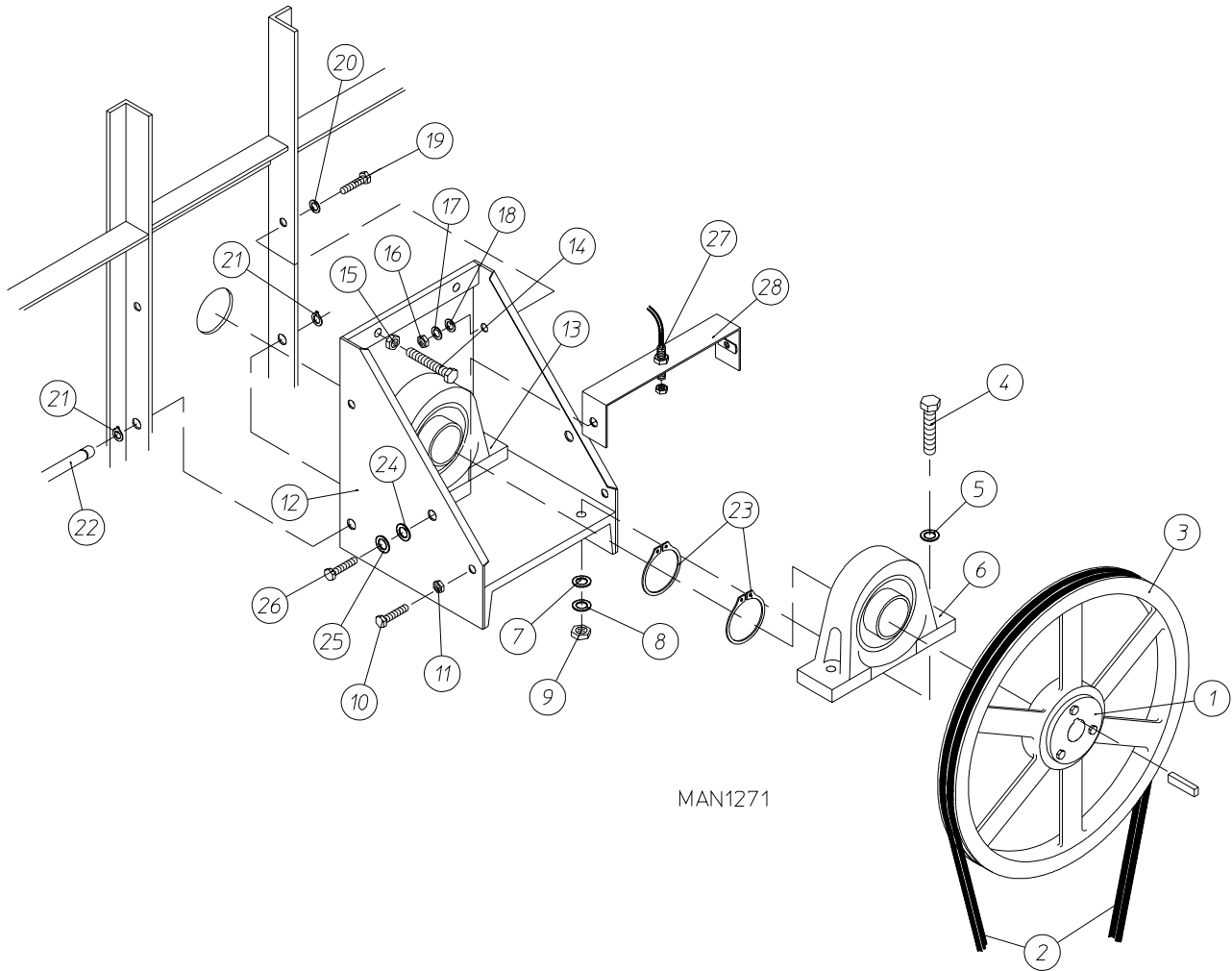

Illus. No.	Part No.	Qty.	Description
1	101108	1	2-1/4" SK Bushing
2*	100104	2	A68 "V" Belt
3	101111	1	AD-115 18" Basket (Tumbler) Pulley
4	150602	4	5/8-11 x 3" Hex Head Machine Bolt
5	153016	4	5/8" Flat Washer
6	100204	1	2-1/4" Pillow Block Bearing ONLY
7	153016	4	5/8" Flat Washer
8	153015	4	5/8" Lock Washer
9	152010	4	5/8-11 Hex Nut
10	150600	2	3/8-16 x 1-1/2" Hex Head Machine Bolt
11	152005	2	3/8-16 Hex Nut
12	801102	1	AD-115 Tumbler Bearing Mount Assembly (includes illus. nos. 4 through 13)
13	100204	1	2-1/4" Pillow Block Bearing ONLY
14	150603	2	1/2-13 x 3" Square Head Machine Bolt
15	152011	2	1/2-13 Hex Nut
16	152005	2	3/8-16 Hex Nut
17	153005	2	3/8" Lock Washer
18	153004	4	3/8" Flat Washer
19	150600	2	3/8-16 x 1-1/2" Hex Head Machine Bolt
20	153004	2	3/8" Flat Washer
21	100801	2	5/8" Retaining Ring
22	301810	1	AD-115 (5/8") Hinge Pin
23	100811	2	2-1/4" Retaining Ring
24	153018	2	1/4" Flat Washer
25	153007	2	1/4" Split Lock Washer
26	150512	2	1/4-20 x 1/2" Hex Head Machine Bolt
27	824807	1	Rotational Sensor Assembly
28	880841	1	Rotational Sensor Mounting Bracket

* Replace in matched sets (both belts).

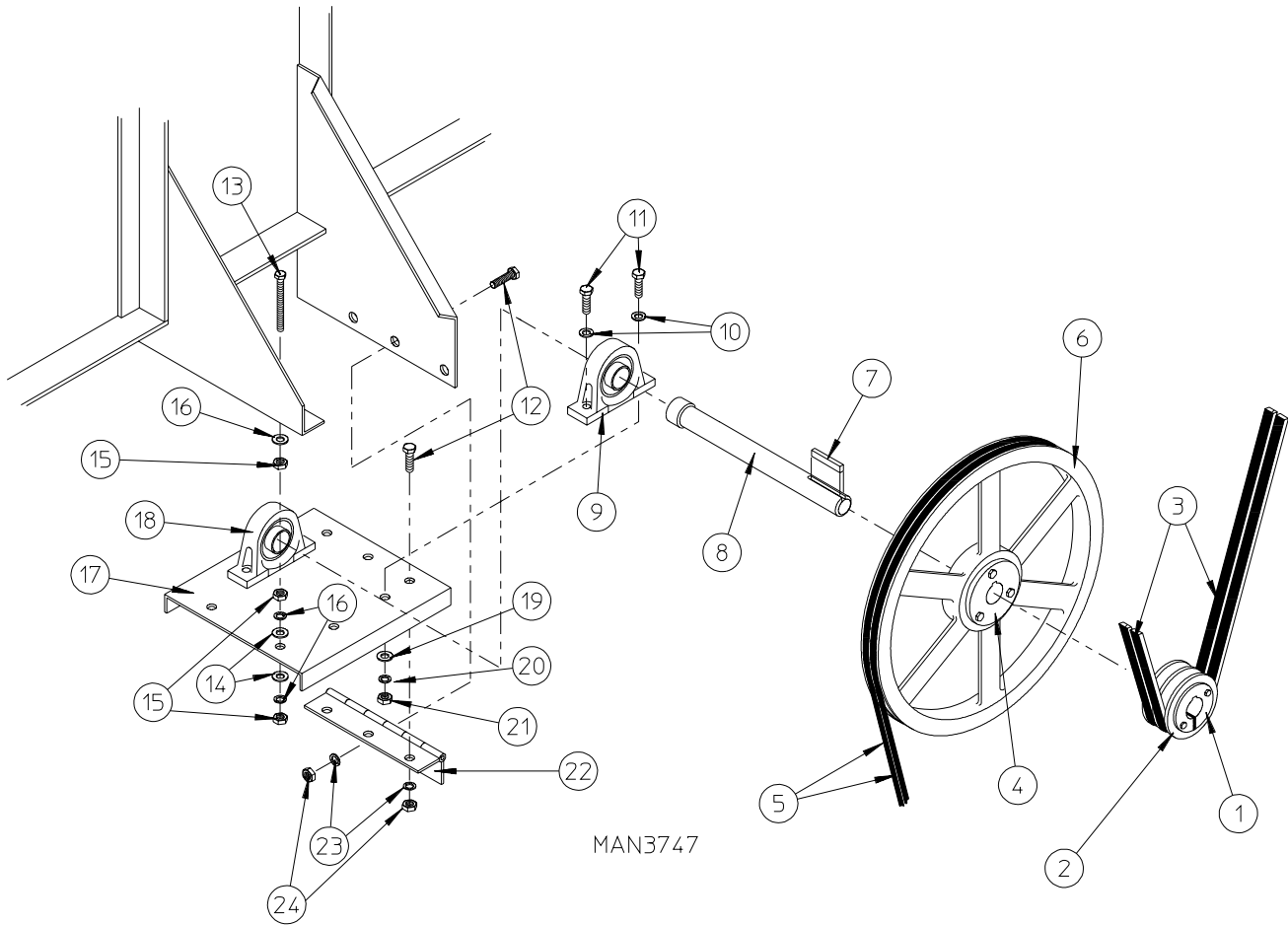

Illus. No.	Part No.	Qty.	Description
1	101110	1	1" Bushing
2	101113	1	2A3.0 Pulley
3*	100104	2	A68 "V" Belt
4	101107	1	1" SK Bushing
5*	100102	2	3V 740 "V" Belt
6	101112	1	19" Idler Pulley
7	100715	1	1/4" x 1/4" x 4-5/8" Key
8	301852	1	AD-115 (1") Idler Shaft ONLY
9	100205	1	1" Pillow Block Bearing
10	153004	4	3/8" Flat Washer
11	150600	4	3/8-16 x 1-1/2" Hex Head Machine Bolt
12	150512	6	1/4-20 x 1/2" Hex Head Machine Bolt
13	150509	2	5/16-18 x 3" Hex Head Machine Bolt
14	153001	6	5/16" Flat Washer
15	152004	6	5/16-18 Hex Nut
16	153002	4	5/16" Lock Washer
17	801001	1	AD-115 Idler Bearing Mount Assembly Complete (includes illus. nos. 7 through 11 and 17 through 25)
	311401	1	AD-115 Idler Bearing Mount ONLY
18	100205	1	1" Pillow Block Bearing
19	153004	4	3/8" Flat Washer
20	153005	4	3/8" Lock Washer
21	152005	4	3/8-16 Hex Nut
22	103005	1	AD-115 Idler Adjustment Hinge ONLY
23	153007	6	1/4" Lock Washer
24	152002	6	1/4-20 Hex Nut

* Replace in matched sets (both belts).

26 AD-115 Totally Enclosed, Fan-Cooled Basket (Tumbler) Motor Mount Assembly

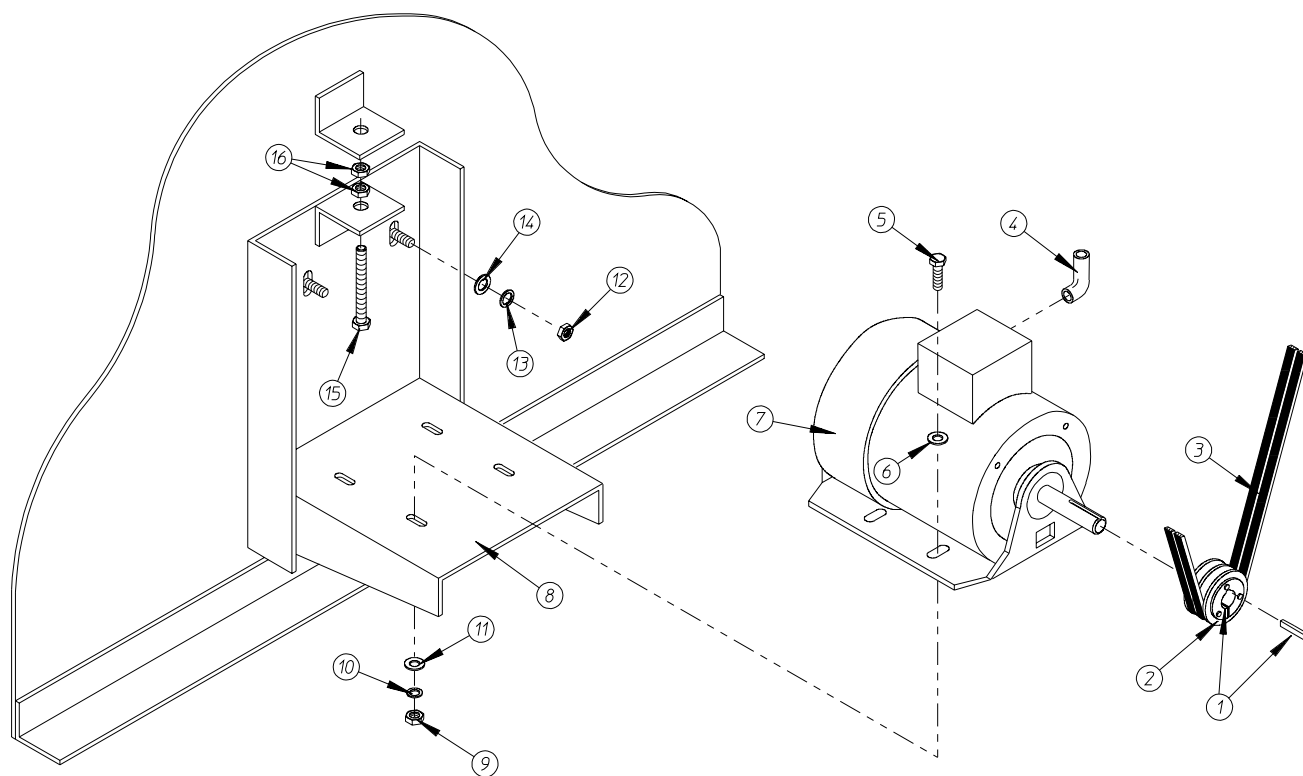

MAN0329

Illus. No.	Part No.	Qty.	Description
1	101121	1	5/8" SK Bushing
2	101114	1	2.65" Pulley (for 60 Hz Models ONLY)
	101120	1	3.15" Pulley (for 50 Hz Models ONLY)
3*	100102	2	3V 740 "V" Belt
4	120200	1	3/8" x 90° Connector
5	150501	4	5/16-18 x 3/4" Hex Head Machine Bolt
6	153001	4	5/16" Flat Washer
7	100029	1	3/4 HP 208/230/280/460v 50/60Hz/3Ø T.E.F.C. Motor (56Z frame)
8	800952	1	AD-115 Basket Motor Mount ONLY (56Z frame)
	800953**	1	AD-115 (60Hz) T.E.F.C. Basket Motor Mount Assembly Complete (includes illus. nos. 1, 2, 5 through 11, 15, and 16) For 60 Hz Models ONLY
	800955**	1	AD-115 (50Hz) T.E.F.C. Basket Motor Mount Assembly Complete (includes illus. nos. 1, 2, 5 through 11, 15, and 16) For 50 Hz Models ONLY
9	152004	4	5/16-18 Hex Nut
10	153002	4	5/16" Lock Washer
11	153001	4	5/16" Flat Washer
12	152004	4	5/16-18 Hex Nut
13	153002	4	5/16" Lock Washer
14	153001	4	5/16" Flat Washer
15	150619	1	3/18-16 x 3" Hex Head Machine Bolt
16	152005	2	3/8-16 Hex Nut

* Replace in matched sets (both belts).

** Specify voltage when ordering.

IMPORTANT: For voltages higher than 460 VAC - 50 Hz, contact the factory for correct part number of motor or motor mount assembly.

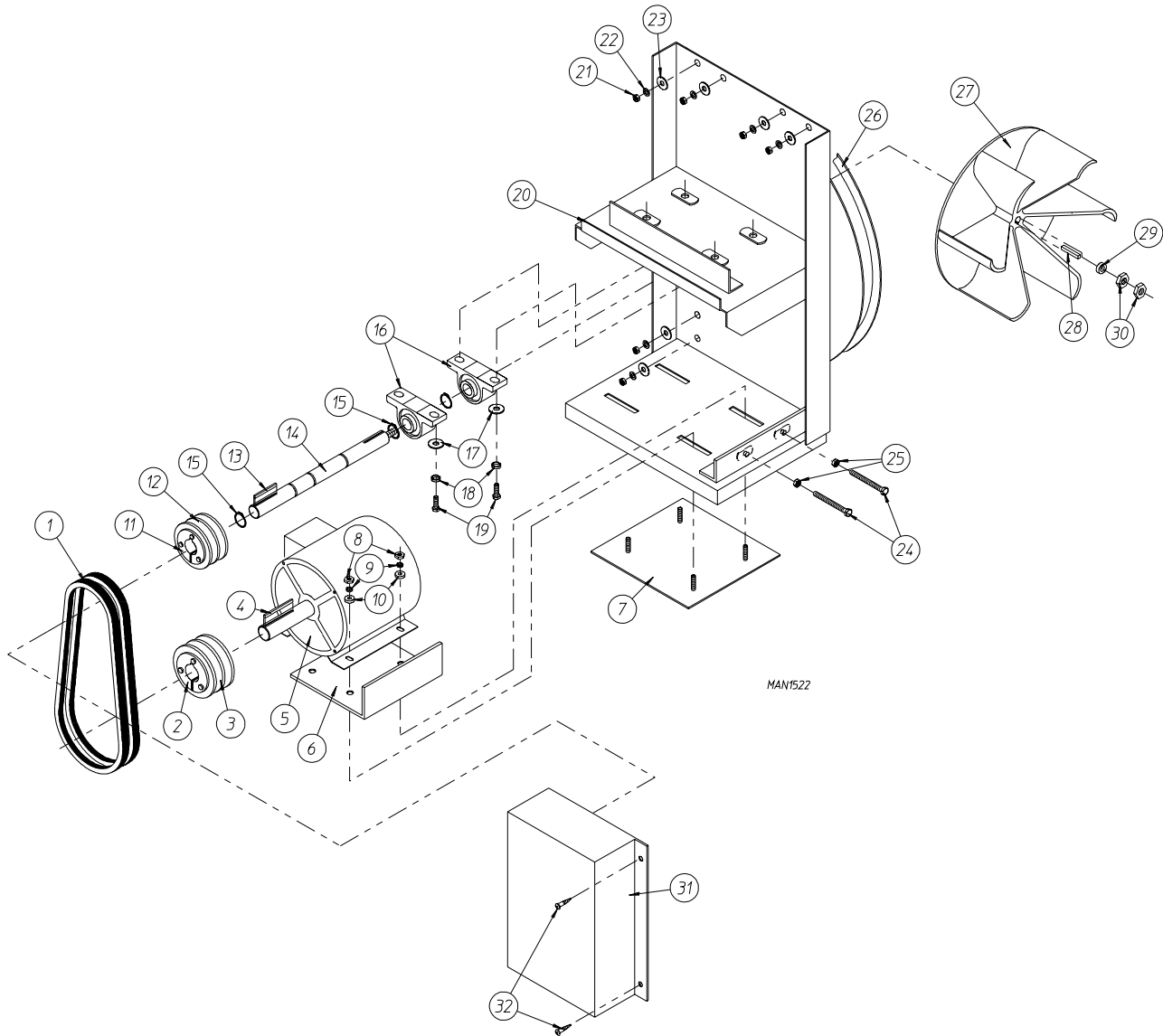

MAN1522

Illus. No.	Part No.	Qty.	Description
1*	100119	2	5L 320 "V" Belt
2	101138	1	SDS x 1-1/8" Bushing
3	101135	1	2B x 5.4 Pulley
4	100706	1	5/16" x 5/16" x 1-3/8" Key
5	100043	1	3 HP 208/230/460v 60Hz and 380/416v 50Hz ONLY 3Ø Motor
	100081	1	3 HP 220v 50Hz 3Ø Motor
6	332198	1	AD-115 Motor Adjustment Plate
7	821012	1	AD115 Motor Bolt Plate Assembly
8	152005	4	#3/8-16 Hex Nut
9	153005	4	3/8" Lock Washer
10	153004	4	3/8" Flat Washer

for Gas Models ONLY

Illus. No.	Part No.	Qty.	Description
11	101194	1	SDS x 1-3/8" Bushing (for 60 Hz Models ONLY)
	101152	1	SH x 1-3/8" Bushing (for 50 Hz Models ONLY)
12	101147	1	2B x 4.8 Pulley (for 60 Hz Models ONLY)
	101148	1	2B x 4.0 Pulley (for 50 Hz Models ONLY)
13	100706	1	5/16" x 5/16" x 1-3/8" Key
14	317400	1	AD-115 Impellor (fan) Shaft
15	100802	2	1-3/8" Retaining Ring
16	880879	2	1-3/8" Pillow Block Bearing with Set Screws and Grease Fitting
	154326	4	5/16 x 3/8" Allen Set Screw ONLY
	170511	2	#1/8-27 N.P.T. Grease Fitting ONLY
17	153004	4	3/8" Flat Washer
18	153005	4	3/8" Lock Washer
19	150601	4	#3/8-16 x 2" Hex Head Machine Bolt
20	850480	1	AD-115 Blower Motor Mount ONLY
	820350*	1	ADG-115 Motor Mount Assembly Complete (includes illus. no. 1 through 20 and 24 through 32) (for 60 Hz Models ONLY)
	820252	1	ADG-115 Motor Mount Assembly Complete (includes illus. no. 1 through 20 and 24 through 32) For 22v 50Hz Models ONLY
	820351*	1	ADG-115 Motor Mount Assembly Complete (includes illus. no. 1 through 20 and 24 through 32) For 380/416v 50Hz Models ONLY
21	152005	8	#3/8-16 Hex Nut
22	153005	8	3/8" Lock Washer
23	153004	8	3/8" Flat Washer
24	150609	2	#1/2-13 x 4-1/2" Hex Head Machine Bolt
25	152011	2	#1/2-13 Hex Nut
26	117600	4	Noise Suppressor Tape (sold in feet)
27	100603	1	16" Impellor with 3/4" Bore
28	100714	1	3/16" x 3/16" x 1-7/8" Key
29	153050	1	1/2" Flat Washer
30	152006	2	#1/2-20 Left Hand Jam Nut
31	820379	1	AD-115 Blower Motor Mount Belt Guard
32	150309	4	#10-16 x 1/2" Hex Head TEK Crimptite Screw

* Replace in matched sets (both belts).

** Specify voltage when ordering.

IMPORTANT: For voltages higher than 460 VAC - 50 Hz, contact the factory for correct part number of motor or motor mount assembly.

for Electric Models ONLY

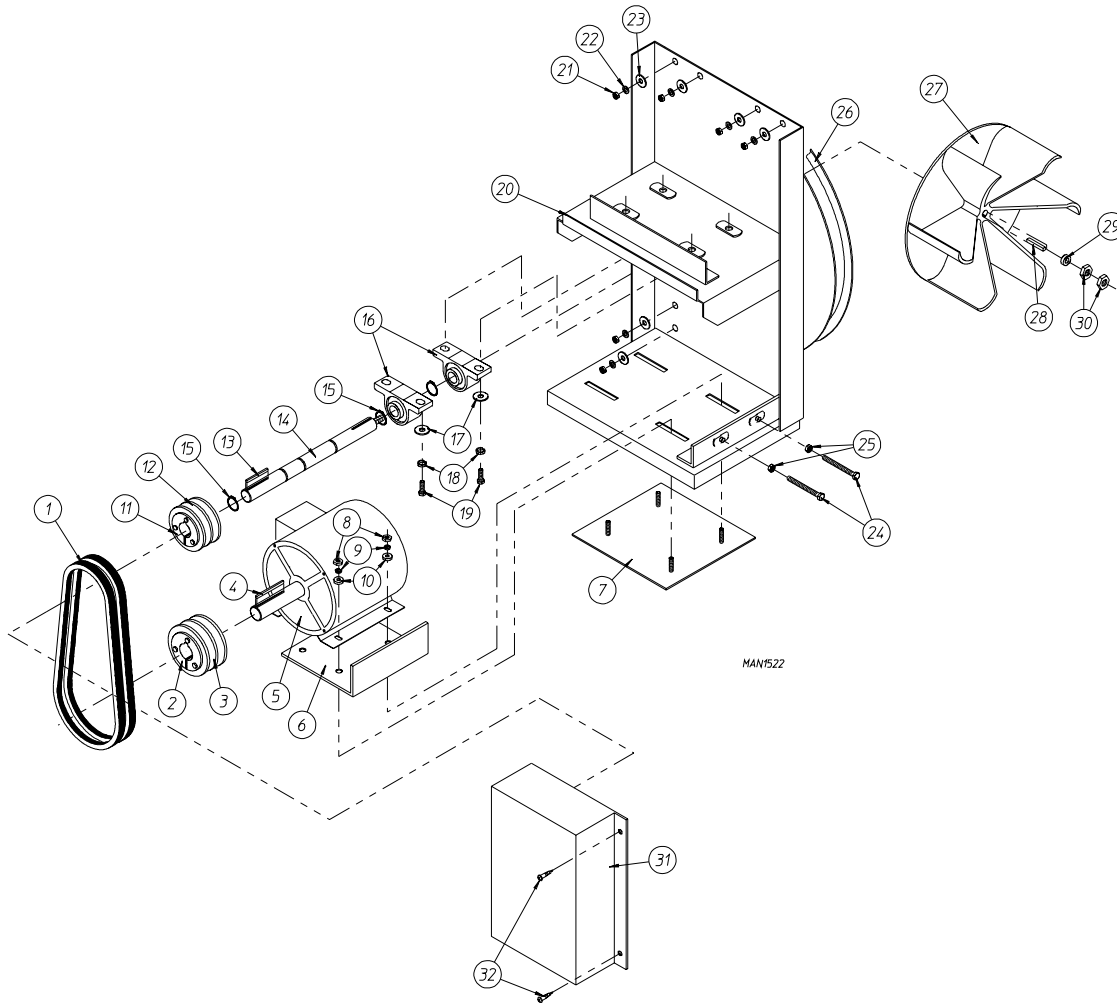

Illus. No.	Part No.	Qty.	Description
1*	100119	2	5L 320 "V" Belt (for 60Hz Models ONLY)
	100118	2	5L 310 "V" Belt (for 50Hz Models ONLY)
2	101138	1	SDS x 1-1/8" Bushing
3	101147	1	2B x 5.4 Pulley
			(for 60 Kw Electric Oven Models ONLY)
	101135	1	2B x 5.4 Pulley
			(for 72 Kw Electric Oven Models ONLY)
	101185	1	2B x 6.2 Pulley
			(for 80 Kw Electric Oven Models ONLY)
4	100706	1	5/16" x 5/16" x 1-3/8" Key
5	100043	1	3 HP 208/230/460v 60Hz and 380/416v 50Hz ONLY 3Ø Motor
	100081	1	3 HP 220v 50Hz 3Ø Motor
6	332198	1	AD-115 Motor Adjustment Plate
7	821012	1	AD115 Motor Bolt Plate Assembly
8	152005	4	#3/8-16 Hex Nut
9	153005	4	3/8" Lock Washer
10	153004	4	3/8" Flat Washer
11	101194	1	SDS x 1-3/8" Bushing (for 60 Hz Models ONLY)
	101152	1	SH x 1-3/8" Bushing (for 50 Hz Models ONLY)
12	101147	1	2B x 4.8 Pulley (for 60 Hz Models ONLY)
	101148	1	2B x 4.0 Pulley (for 50 Hz Models ONLY)

for Electric Models ONLY

Illus. No.	Part No.	Qty.	Description
13	100706	1	5/16" x 5/16" x 1-3/8" Key
14	317400	1	AD-115 Impellor (fan) Shaft
15	100802	2	1-3/8" Retaining Ring
16	880879	2	1-3/8" Pillow Block Bearing with Set Screws and Grease Fitting
	154326	4	5/16 x 3/8" Allen Set Screw ONLY
	170511	2	#1/8-27 N.P.T. Grease Fitting ONLY
17	153004	4	3/8" Flat Washer
18	153005	4	3/8" Lock Washer
19	150601	4	#3/8-16 x 2" Hex Head Machine Bolt
20	850480	1	AD-115 Blower Motor Mount ONLY
	820352**	1	ADE-115 - 60 Kw Motor Mount Assembly Complete (includes illus. no. 1 through 20 and 24 through 32) For 60Hz Models ONLY
	820353**	1	ADE-115 - 60 Kw Motor Mount Assembly Complete (includes illus. no. 1 through 20 and 24 through 32) For 380/416v 50Hz Models ONLY
	820251	1	ADE-115 - 60 Kw Motor Mount Assembly Complete (includes illus. no. 1 through 20 and 24 through 32) For 220v 50Hz Models ONLY
	820350**	1	ADE-115 - 72 Kw Motor Mount Assembly Complete (includes illus. no. 1 through 20 and 24 through 32) For 60Hz Models ONLY
	820351**	1	ADE-115 - 72 Kw Motor Mount Assembly Complete (includes illus. no. 1 through 20 and 24 through 32) For 380/416v 50Hz Models ONLY
	820252	1	ADE-115 - 72 Kw Motor Mount Assembly Complete (includes illus. no. 1 through 20 and 24 through 32) For 220v 50Hz Models ONLY
	800959**	1	ADE-115 - 80 Kw Motor Mount Assembly Complete (includes illus. no. 1 through 20 and 24 through 32) For 60Hz Models ONLY
	800960**	1	ADE-115 - 80 Kw Motor Mount Assembly Complete (includes illus. no. 1 through 20 and 24 through 32) For 380/416v 50Hz Models ONLY
	820254	1	ADE-115 - 80 Kw Motor Mount Assembly Complete (includes illus. no. 1 through 20 and 24 through 32) For 220v 50Hz Models ONLY
21	152005	8	#3/8-16 Hex Nut
22	153005	8	3/8" Lock Washer
23	153004	8	3/8" Flat Washer
24	150609	2	#1/2-13 x 4-1/2" Hex Head Machine Bolt
25	152011	2	#1/2-13 Hex Nut
26	117600	4	Noise Suppressor Tape (sold in feet)
27	100603	1	16" Impellor with 3/4" Bore
28	100714	1	3/16" x 3/16" x 1-7/8" Key
29	153050	1	1/2" Flat Washer
30	152006	2	#1/2-20 Left Hand Jam Nut
31	820379	1	AD-115 Blower Motor Mount Belt Guard
32	150309	4	#10-16 x 1/2" Hex Head TEK Crimptite Screw

* Replace in matched sets (both belts).

** Specify voltage when ordering.

IMPORTANT: For voltages higher than 460 VAC - 50 Hz, contact the factory for correct part number of motor or motor mount assembly.

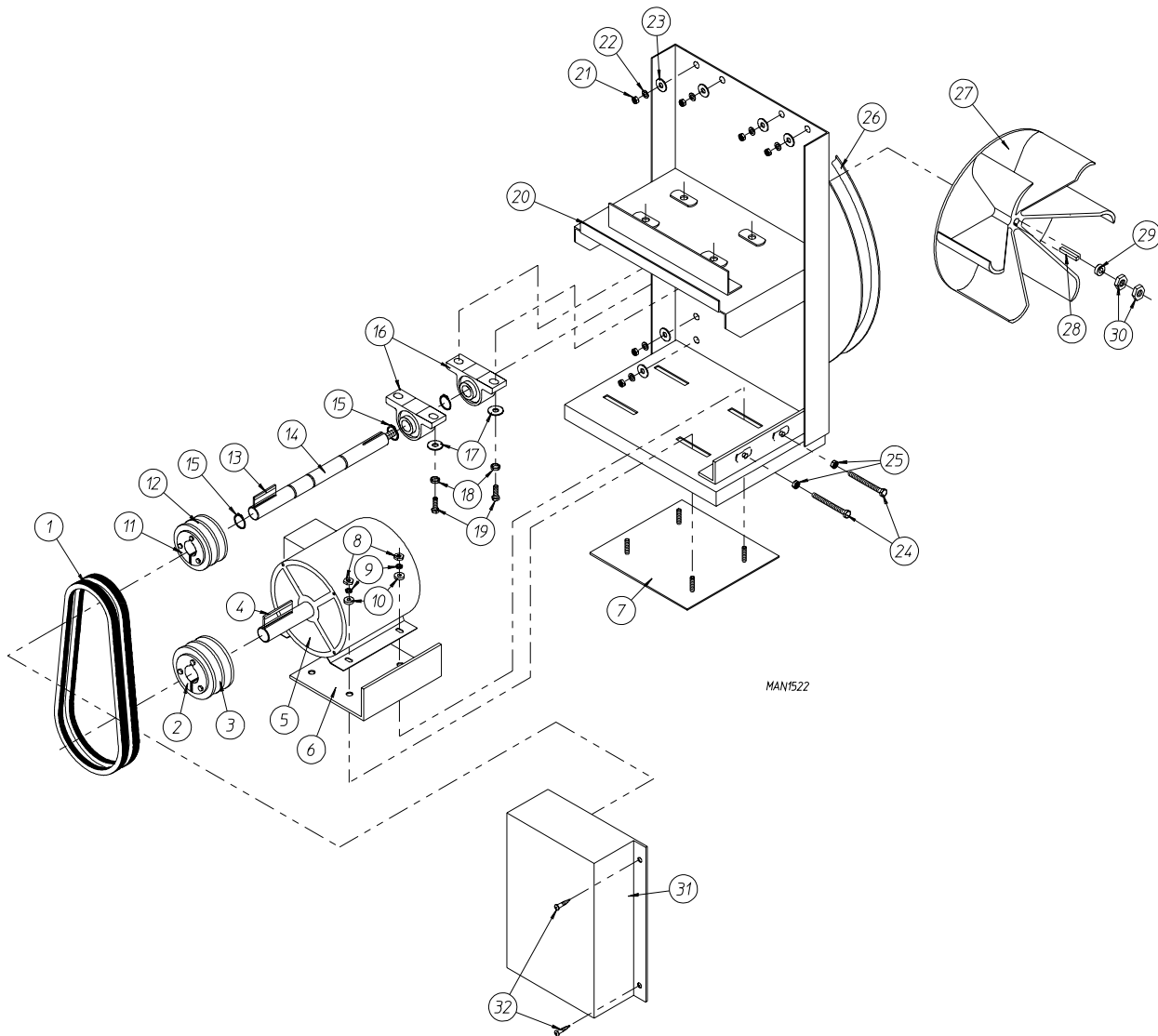

Illus. No.	Part No.	Qty.	Description
1*	100145	2	BX-32 "V" Belt (for 60Hz Models ONLY)
	100119	2	5L 320 "V" Belt (for 50Hz Models ONLY)
2	101138	1	SDS x 1-1/8" Bushing
3	101175	1	2B x 6.8 Pulley
4	100706	1	5/16" x 5/16" x 1-3/8" Key
5	100043	1	3 HP 208/230/460v 60Hz and 380/416v 50Hz ONLY 3Ø Motor
	100081	1	3 HP 220v 50Hz 3Ø Motor
6	332198	1	AD-115 Motor Adjustment Plate
7	821012	1	AD115 Motor Bolt Plate Assembly
8	152005	4	#3/8-16 Hex Nut
9	153005	4	3/8" Lock Washer
10	153004	4	3/8" Flat Washer
11	101194	1	SDS x 1-3/8" Bushing (for 60 Hz Models ONLY)
	101152	1	SH x 1-3/8" Bushing (for 50 Hz Models ONLY)
12	101147	1	2B x 4.8 Pulley (for 60 Hz Models ONLY)
	101148	1	2B x 4.0 Pulley (for 50 Hz Models ONLY)

for Steam Models ONLY

Illus. No.	Part No.	Qty.	Description
13	100706	1	5/16" x 5/16" x 1-3/8" Key
14	317400	1	AD-115 Impellor (fan) Shaft
15	100802	2	1-3/8" Retaining Ring
16	880879	2	1-3/8" Pillow Block Bearing with Set Screws and Grease Fitting
	154326	4	5/16 x 3/8" Allen Set Screw ONLY
	170511	2	#1/8-27 N.P.T. Grease Fitting ONLY
17	153004	4	3/8" Flat Washer
18	153005	4	3/8" Lock Washer
19	150601	4	#3/8-16 x 2" Hex Head Machine Bolt
20	850480	1	AD-115 Blower Motor Mount ONLY
	820383**	1	ADS-115 Motor Mount Assembly Complete (includes illus. no. 1 through 20 and 24 through 32) For 60Hz Models ONLY
	820253	1	ADS-115 Motor Mount Assembly Complete (includes illus. no. 1 through 20 and 24 through 32) For 220v 50Hz Models ONLY
	820384**	1	ADE-115 Motor Mount Assembly Complete (includes illus. no. 1 through 20 and 24 through 32) For 380/416v 50Hz Models ONLY
21	152005	8	#3/8-16 Hex Nut
22	153005	8	3/8" Lock Washer
23	153004	8	3/8" Flat Washer
24	150609	2	#1/2-13 x 4-1/2" Hex Head Machine Bolt
25	152011	2	#1/2-13 Hex Nut
26	117600	4	Noise Suppressor Tape (sold in feet)
27	100603	1	16" Impellor with 3/4" Bore
28	100714	1	3/16" x 3/16" x 1-7/8" Key
29	153050	1	1/2" Flat Washer
30	152006	2	#1/2-20 Left Hand Jam Nut
31	820379	1	AD-115 Blower Motor Mount Belt Guard
32	150309	4	#10-16 x 1/2" Hex Head TEK Crimptite Screw

* Replace in matched sets (both belts).

** Specify voltage when ordering.

IMPORTANT: For voltages higher than 460 VAC - 50 Hz, contact the factory for correct part number of motor or motor mount assembly.

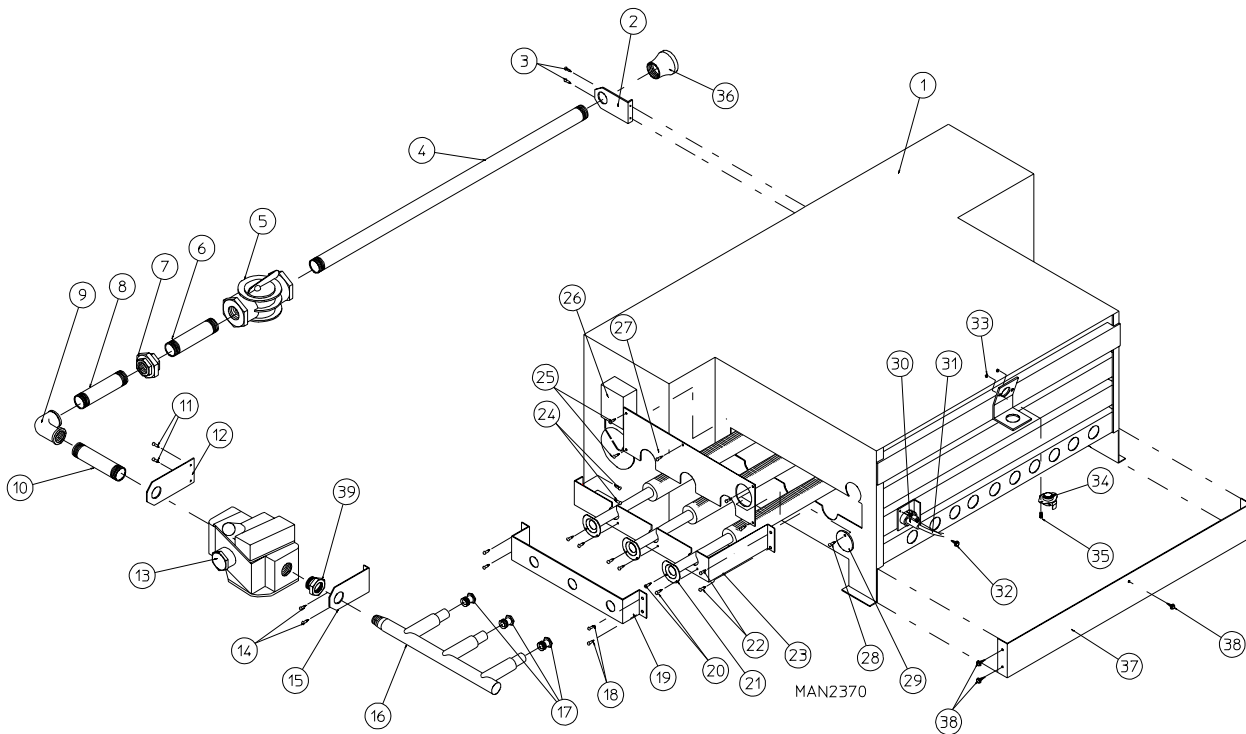

Illus. No.	Part No.	Qty.	Description
1	880874*	1	ADG-115 DSI Natural Gas Burner Assembly Complete Less Orifices (includes illus. nos. 1 through 16, 18 through 36, and 39)
	880875*	1	ADG-115 DSI L.P. Burner Assembly Complete Less Orifices (includes illus. nos. 1 through 16 and 18 through 39)
	820201	1	ADG-115 Burner Box ONLY
2	331291	1	ADG-115 Pipe Bracket (for models mfd. as of February 1, 1995)
	318364	1	ADG-115 Pipe Bracket (for models mfd. prior to February 1, 1995)
3	150309	2	#10-16 x 1/2" Hex Head TEK Crimptite Screw
4	142813	1	3/4" x 33-1/2" Nipple (for models mfd. as of February 1, 1995)
	142821	1	3/4" x 36" Nipple (for models mfd. prior to February 1, 1995)
5	141300	1	3/4" Union Shutoff
6	142701	1	3/4" Close Nipple
7	142601	1	3/4" Union
8	142710	1	3/4" x 4" Nipple (for models mfd. as of February 1, 1995)
	142701	1	3/4" Close Nipple (for models mfd. prior to February 1, 1995)

for Gas Models ONLY

Illus. No.	Part No.	Qty.	Description
9	142504	1	3/4" x 90° Elbow
10	142710	1	3/4" x 4" Nipple (for models mfd. as of February 1, 1995)
	142734	1	3/4" x 5-1/2" Nipple (for models mfd. as of February 1, 1995)
11	150309	2	#10-16 x 1/2" Hex Head TEK Crimptite Screw
12	354030	1	ADG-115 Flat Gas Pipe Bracket
13	140026	1	DSI 3/4" 24 VAC Redundant (natural gas) Gas Valve
	140411	1	24 VAC Gas Valve L.P. (liquid propane) Conversion Kit
14	150309	2	#10-16 x 1/2" Hex Head TEK Crimptite Screw
15	331291	1	ADG-115 Gas Valve Pipe Bracket
16	141208	1	3-Port Manifold
17**	140837	3	#8 Burner Orifice (natural gas) ONLY
	140818	3	#31 Burner Orifice (liquid propane gas) ONLY
18	150309	4	#10-16 x 1/2" Hex Head TEK Crimptite Screw
19	331288	1	ADG-115 Manifold Support ONLY
20	150309	6	#10-16 x 1/2" Hex Head TEK Crimptite Screw
21	141110	3	ADG-115 Burner Tube ONLY
22	150309	2	#10-16 x 1/2" Hex Head TEK Crimptite Screw
23	331287	1	ADG-115 Burner Tube Support ONLY
24	150309	2	#10-16 x 1/2" Hex Head TEK Crimptite Screw
25	150309	6	#10-16 x 1/2" Hex Head TEK Crimptite Screw
26	-----	1	Sail Switch (refer to Sail Switch Assembly on page 37)
27	331289	1	ADG-115 Burner Box Cover Plate ONLY
28	150309	1	#10-16 x 1/2" Hex Head TEK Crimptite Screw
29	331290	1	ADG-115 Ignitor/Flame-Probe Sight Hole Disc ONLY
30	880325	1	ADG-115 Ignitor/Flame-Probe Assembly Kit (includes high voltage [HV] wire and connector)
	305410	1	DSI Ignitor Gap Feeler Gauge ... Not Illustrated
31	880330	1	DSI Ignitor HV Wire/Connector ONLY
32	150309	2	#10-16 x 1/2" Hex Head TEK Crimptite Screw
33	151000	2	#6-32 Pal Nut
34	130401	1	330° Hi-Limit ONLY
35	150001	2	#6-32 x 1/2" Round Head Machine Screw
36	142924	1	1" to 3/4" Reducing Coupling
37	332256	1	L.P. Burner Baffle (for L.P. Models ONLY)
38	150309	5	#10-16 x 1/2" Hex Head TEK Crimptite Screw
---	880876**	1	ADG-115 DSI L.P. Conversion Kit
39	142907	1	3/4" to 1/2" Reducing Bushing

* Orifices are not included and must be ordered separately.

** Consult factory for elevations over 2,000 feet.

for Gas Models ONLY

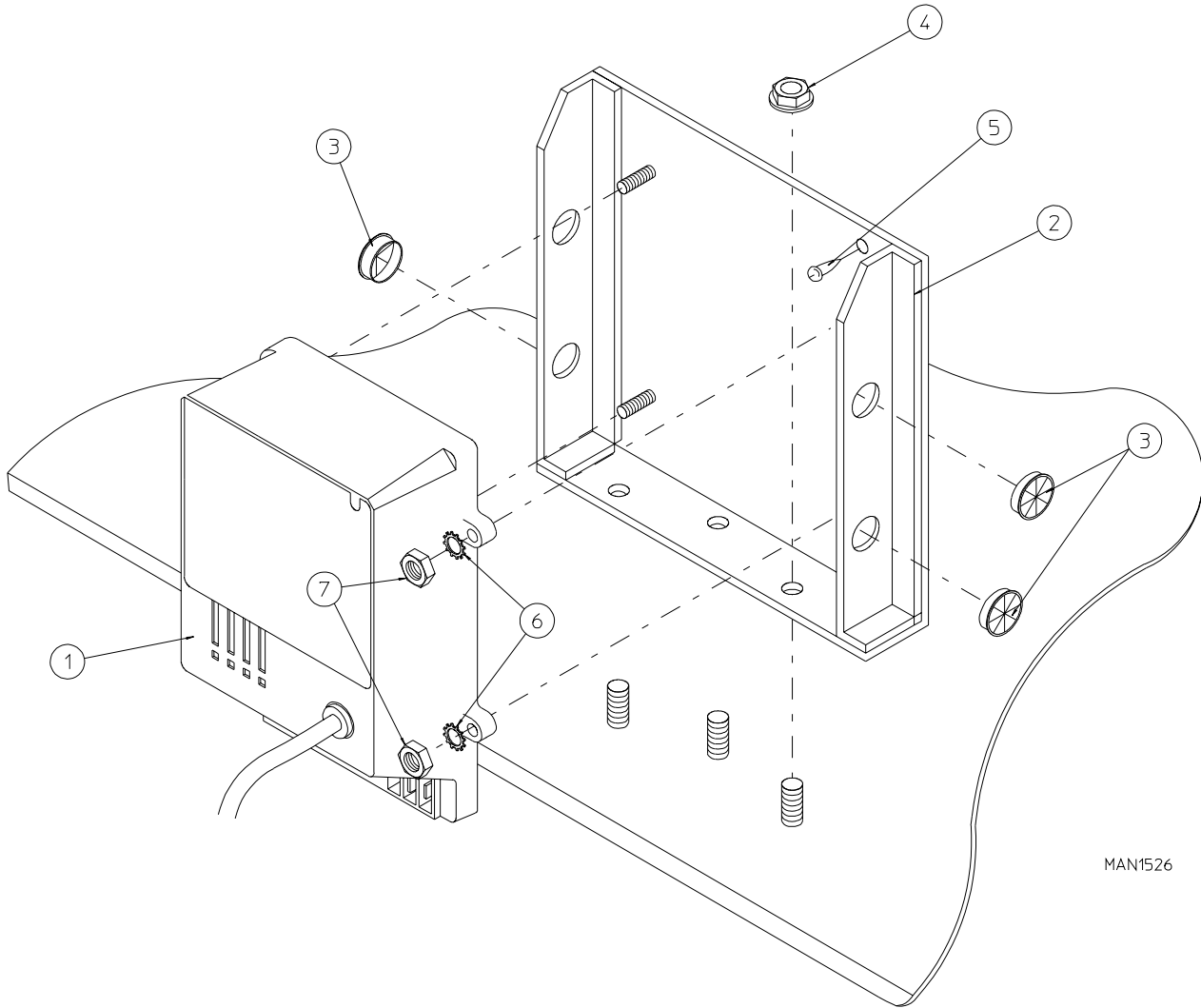

Illus. No.	Part No.	Qty.	Description
1	880815	1	ADC DSI Module ONLY - 50/60 Hz
2	820100	1	ADG-115 DSI Module Mount Assembly ONLY
3	121400	3	Universal Bushing
4	152014	3	1/4-20 Free Spin Wash Nut
5	150301	1	#8-18 x 7/16" Phillips Pan Head TEK Screw
6	153010	4	#6 Star Washer
7	152000	4	#6-32 Hex Nut

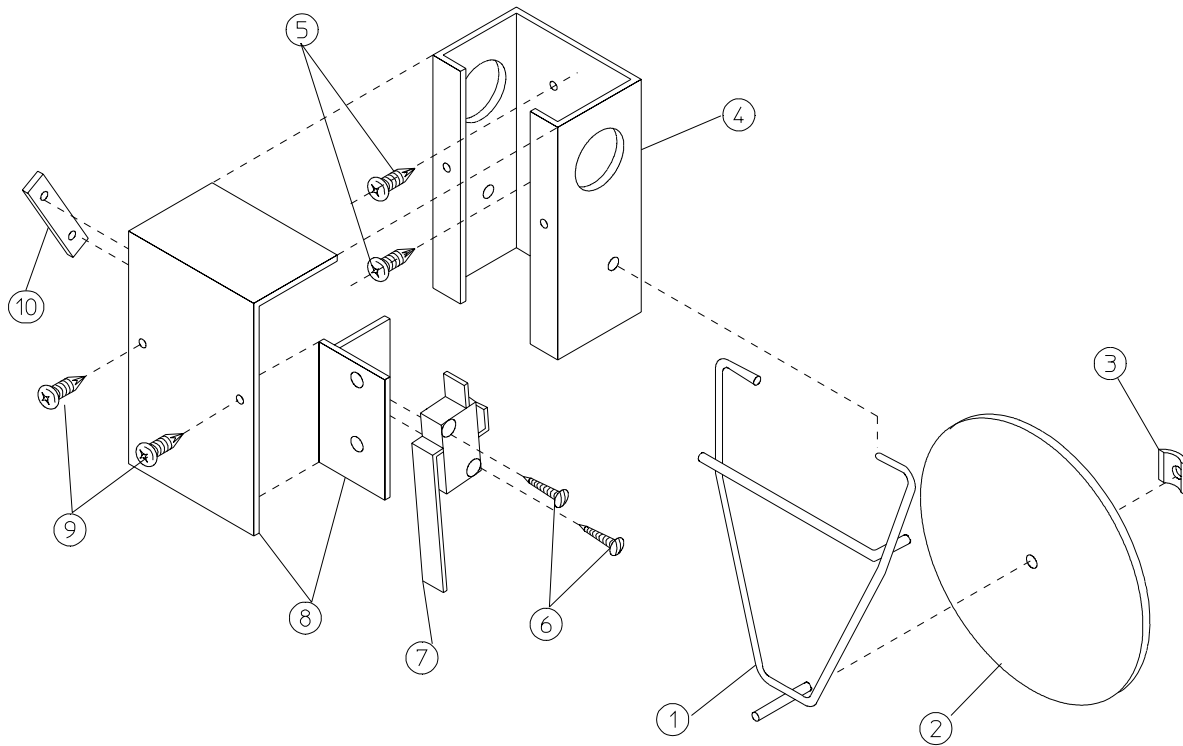

MAN0440

Illus. No.	Part No.	Qty.	Description
1	105500	1	Sail Switch Actuator Rod
2	319202	1	Sail Switch Damper (flat)
3	154002	1	1/8" Push-on Fastener
4	802800	1	Sail Switch Box with Cover and Bracket ONLY
	802801	1	Sail Switch Box Assembly Complete (includes illus. nos. 1 through 4 and 6 through 10)
5	150300	2	#10 x 1/2" Hex Washer TEK Screw
6	150303	2	#4 x 3/4" Pan Head "A" Machine Screw
7	122200	1	Sail Switch ONLY
8	802799	1	Sail Switch Box Cover and Bracket ONLY
9	150309	2	#10-16 X 1/2" Hex Head TEK Crimpite Screw
10	154004	1	Twin Speed Nut

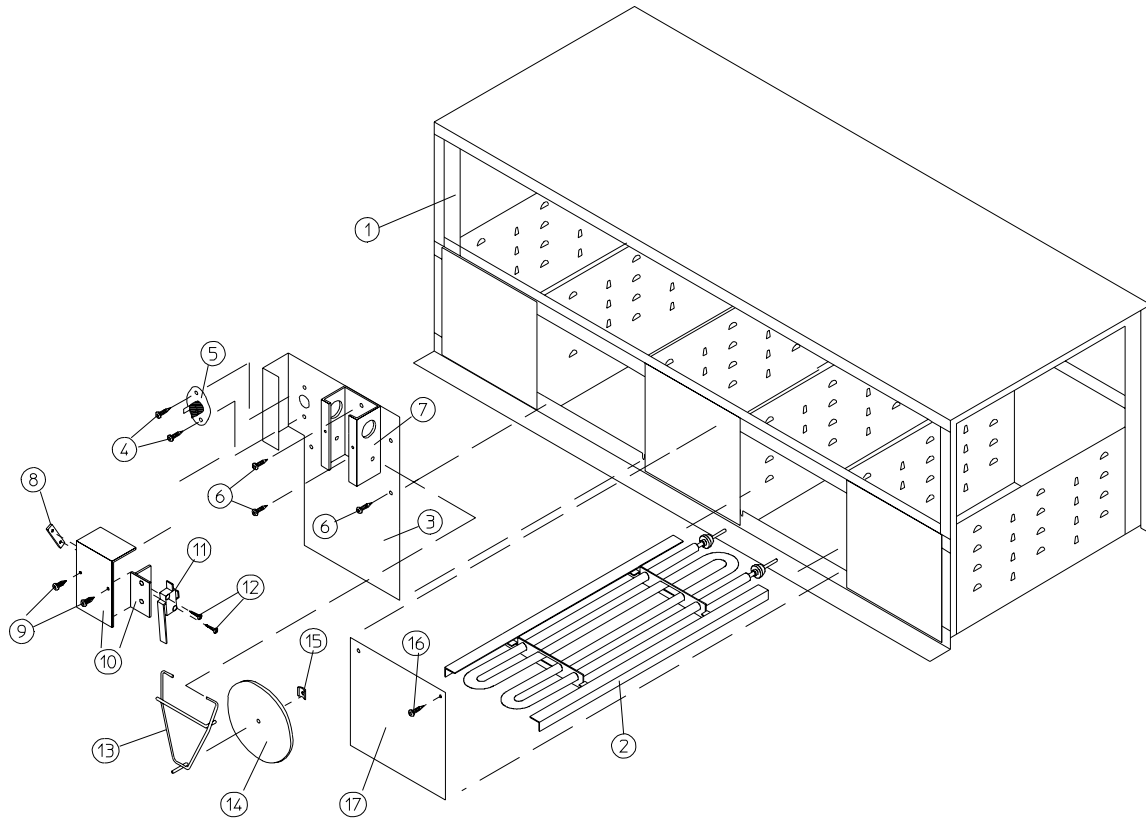

MAN1638

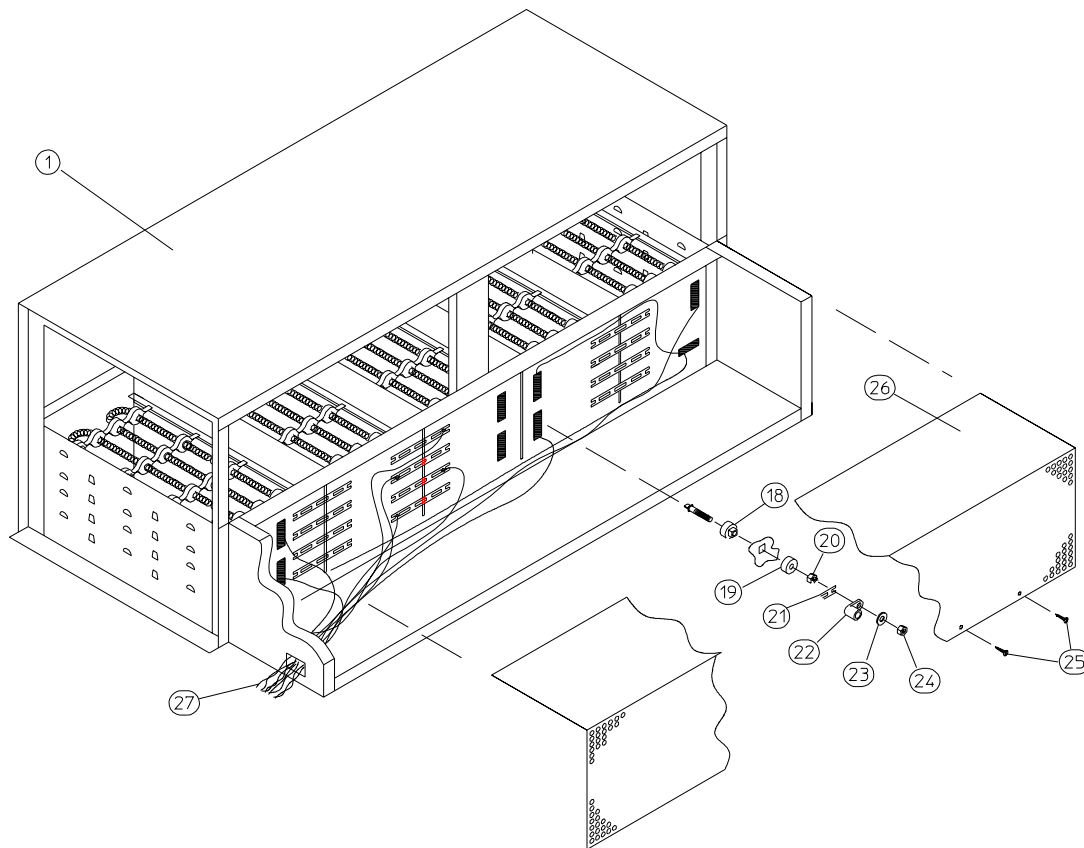

Illus. No.	Part No.	Qty.	Description
1	803015	1	ADE-115 Electric Oven Box ONLY
	-----*	1	Electric Oven Assembly Complete
2	-----*	18	Electric Element
3	802802	1	ADE-115 Safety Control Bracket ONLY
4	150301	2	#8-18 x 7/16" Phillips Pan Head TEK Screw
5	130400	1	290° Hi-Limit ONLY
6	150309	4	#10-16 x 1/2" Hex Head TEK Crimptite Screw
7	802800	1	Sail Switch Box with Cover and Bracket ONLY
	802801	1	Sail Switch Box Assembly Complete (includes illus. nos. 7 through 15)
8	154004	1	Twin Speed Nut
9	150309	2	#10-16 x 1/2" Hex Head TEK Crimptite Screw
10	802799	1	Sail Switch Box Cover and Bracket ONLY
11	122200	1	Sail Switch ONLY
12	150303	2	#4 x 3/4" Pan Head "A" Machine Screw
13	105500	1	Sail Switch Actuator Rod
14	319202	1	Sail Switch Damper (flat)
15	154002	1	1/8" Push-On Fastener
16	150309	8	#10-16 x 1/2" Hex Head TEK Crimptite Screw
17	803101	4	ADE-115 Element Cover ONLY
18	120081	36	Internal Ceramic Insulator
19	120080	36	External Ceramic Insulator
20	152008	36	#10-32 Hex Nut
21	121011*	--	Bus Bar (sold in fet)
22	121010*	--	Terminal Lug
23	153009	36	#10 Star Washer
24	152008	36	#10-32 Hex Nut
25	150309	14	#10-16 x 1/2" Hex Head TEK Crimptite Screw
26	320822	1	ADE-115 Cover ONLY
27	-----*	--	Oven Wire (sold in feet)

* Refer to **ADE-115 60 Kw Electric Oven Component Application Charts** on **page 52**.

Refer to **ADE-115 72 Kw and 80 Kw Electric Oven Component Application Charts** on **page 53**.

208/240 VAC - 50/60 Hz - 3Ø

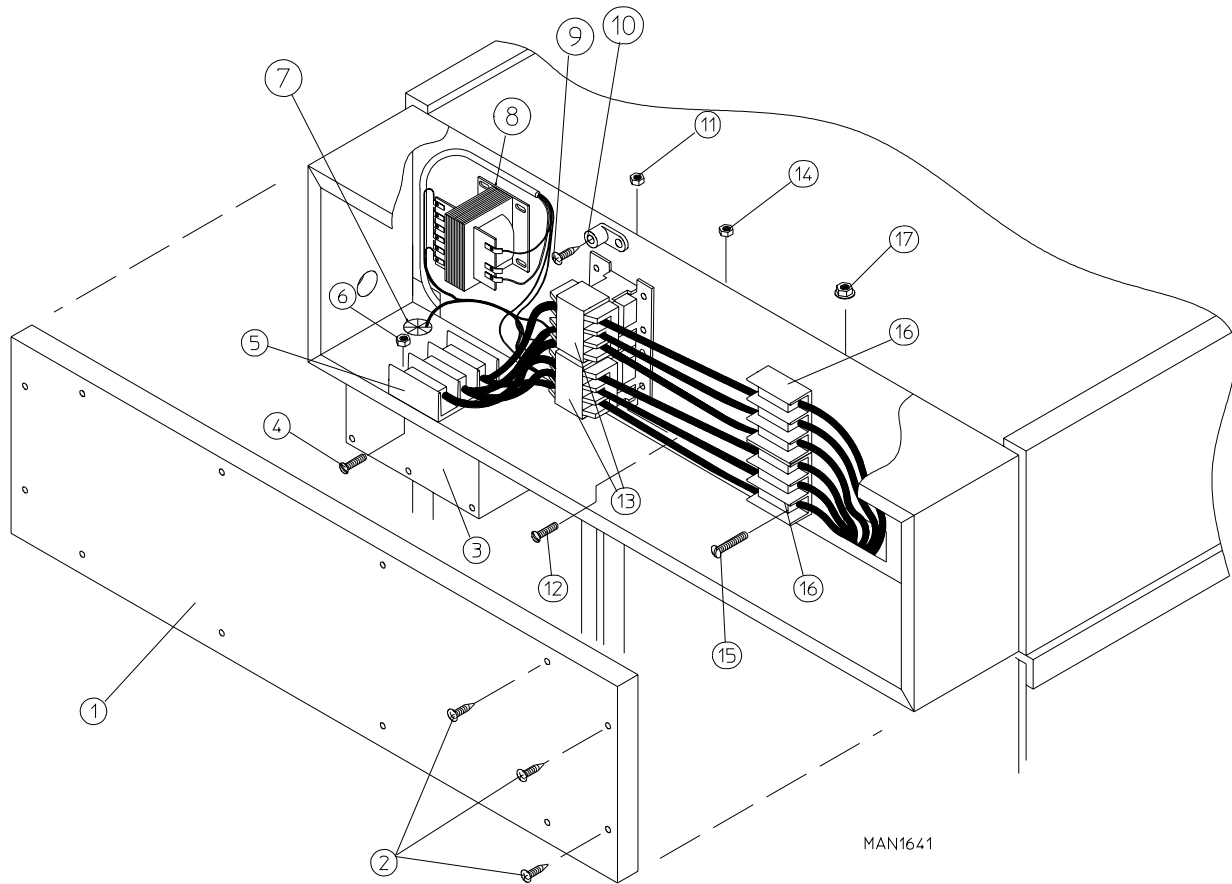

Illus. No.	Part No.	Qty.	Description
1	320902	1	ADE-115 Electric Oven Relay Box Cover
2	150301	12	#8-18 x 7/16" Phillips Pan Head TEK Screw
3	322808	1	Control Box Cover Plate ONLY
4	150108	2	#8-32 x 1/2" Pan Head Machine Screw
5	120710	1	Power Distribution Block
6	151001	2	#8-32 Pal Nut
7	121400	2	Universal Busing
8	132004	1	Transformer (for ALL Microprocessor [computer] Models and Timer Models)
9	150108	1	#8-32 x 1/2" Pan Head Machine Screw
10	121010	1	L-70 Ground Lug
11	151001	1	#8-32 Pal Nut
12	150108	3	#8-32 x 1/2" Pan Head Machine Screw
13	131385	2	TPST 112-Amp, 24 VAC Relay
14	151001	3	#8-32 Pal Nut
15	150521	4	1/4-20 x 2" Carriage Bolt
16	120706	2	Power Distribution Block
17	152014	4	1/4-20 Free Spin Wash Nut

380/416/480 VAC - 50/60 Hz - 3Ø

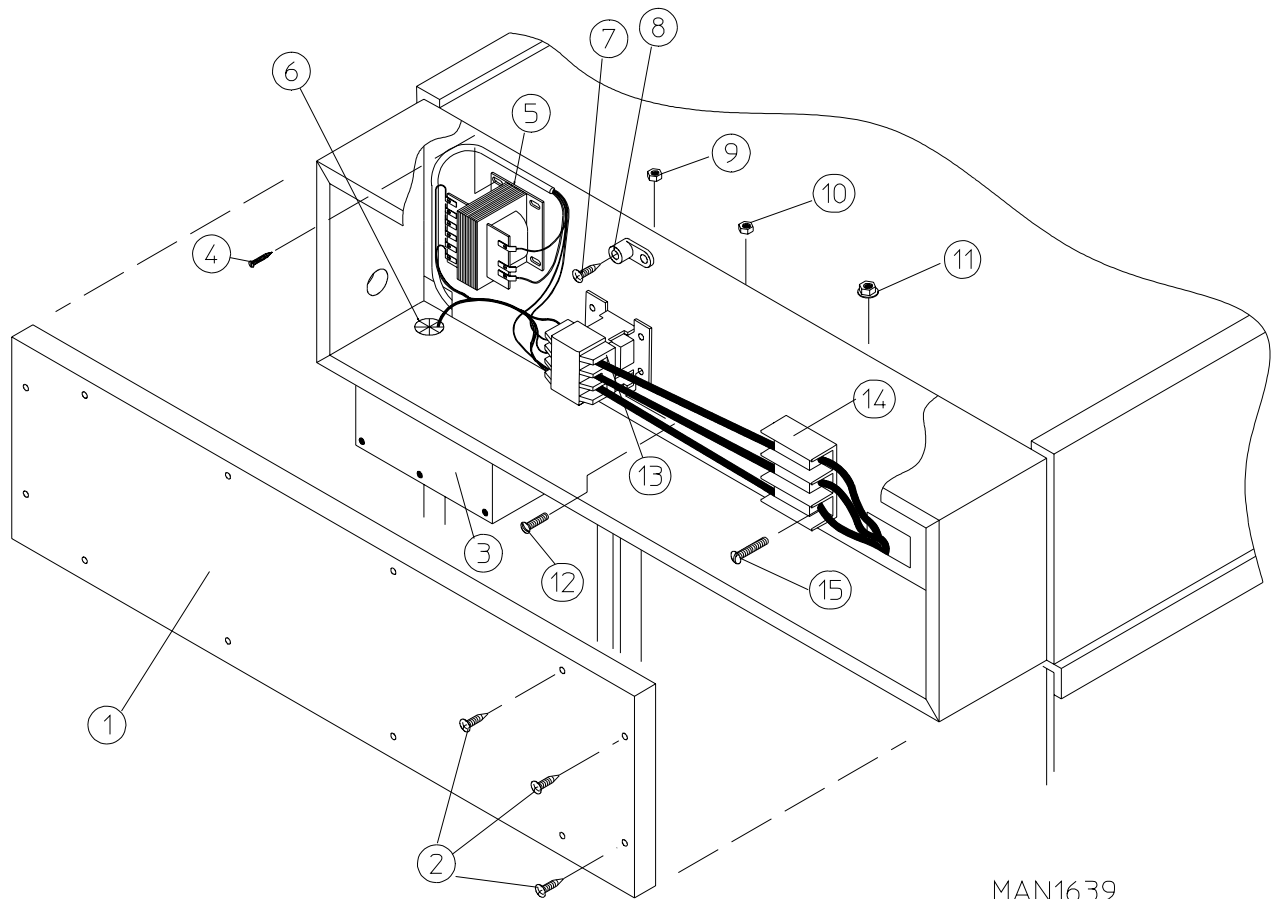

MAN1639

Illus. No.	Part No.	Qty.	Description
1	320902	1	ADE-115 Electric Oven Relay Box Cover
2	150301	12	#8-18 x 7/16" Phillips Pan Head TEK Screw
3	322808	1	Control Box Cover Plate ONLY
4	150300	3	#10 x 1/2" Hex Washer TEK Screw
5	132004	1	Transformer (for ALL Electric Models - 380 VAC thru 480 VAC)
6	121400	2	Universal Bushing
7	150108	3	#8-32 x 1/2" Pan Head Machine Screw
8	121010	1	L-70 Terminal Lug
9	151001	1	#8-32 Pal Nut
10	151001	3	#8-32 Pal Nut
11	152014	2	1/4-20 Free Spin Wash Nut
12	150108	1	#8-32 x 1/2" Pan Head Machine Screw
13	131385	1	TSPT 112-Amp, 24 VAC Relay
14	120706	1	Power Distribution Block
15	150521	2	1/4-20 x 2" Carriage Bolt

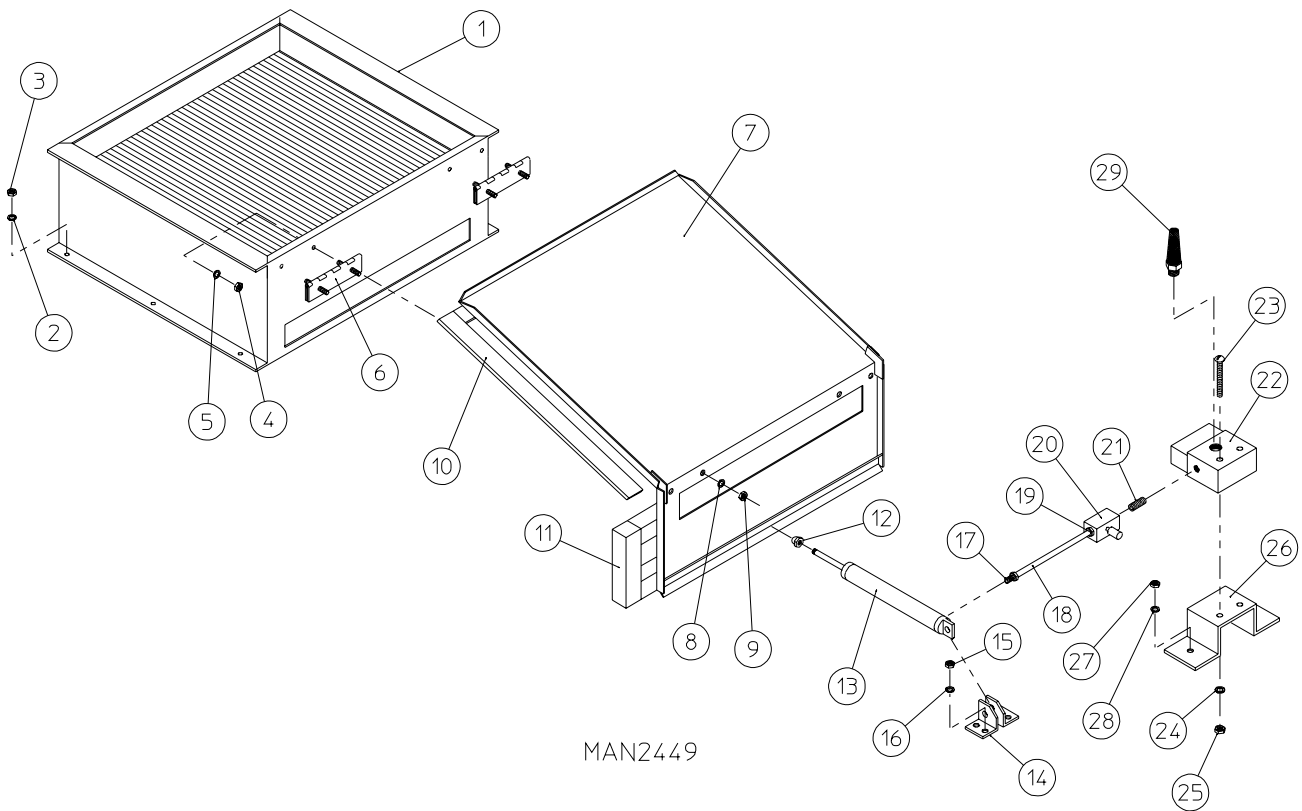

Illus. No.	Part No.	Qty.	Description
1	165012	1	ADS-115 Steam Coil Assembly
	165019	1	ADS-115 Steel Steam Coil Assembly
2	153002	6	5/16" Lock Washer
3	152004	6	5/16-18 Hex Nut
4	152002	4	1/4-20 Hex Nut
5	153007	4	1/4" Lock Washer
6	820321	2	ADS-115 Steam Damper Hinge Assembly
7	820320	1	ADS-115 Steam Damper Assembly (includes illus. nos. 7, 10, and 11)
8	153007	4	1/4" Lock Washer
9	152002	4	1/4-20 Hex Nut
10	115995	84	ADS-115 Steam Damper Gasket (sold by the inch)
11	102350	1	ADS-115 Steam Damper Foam (68-1/2" length)
12	151007	1	7/16-20 Stainless Steel Acorn Nut
13	100499	1	1-1/2" Bore x 3" Stroke Piston
14	100500	1	Piston Support Bracket
15	152002	4	1/4-20 Hex Nut
16	153007	4	1/4" Lock Washer
17	100472	1	1/4" x 1/8" Connector
18	143110	1	1/4" Tubing (sold in feet)
19	100472	1	1/4" x 1/8" Connector
20	100496	1	1/8" Needle Valve
21	143238	1	1/8" Close Nipple
22	100498	1	3-Way Micro Valve - 24 VAC
23	150002	2	#6-32 x 1" Slotted Machine Screw
24	153010	2	#6 Star Washer
25	152000	2	#6-32 Hex Nut
26	330987	1	Micro Valve Support Bracket
27	152002	2	1/4-20 Hex Nut
28	153007	2	1/4" Lock Washer
29	100520	1	1/8" NPT Silencer (muffler)

for Gas and Steam Models, and for Electric Models mfd. prior to March 29, 1995

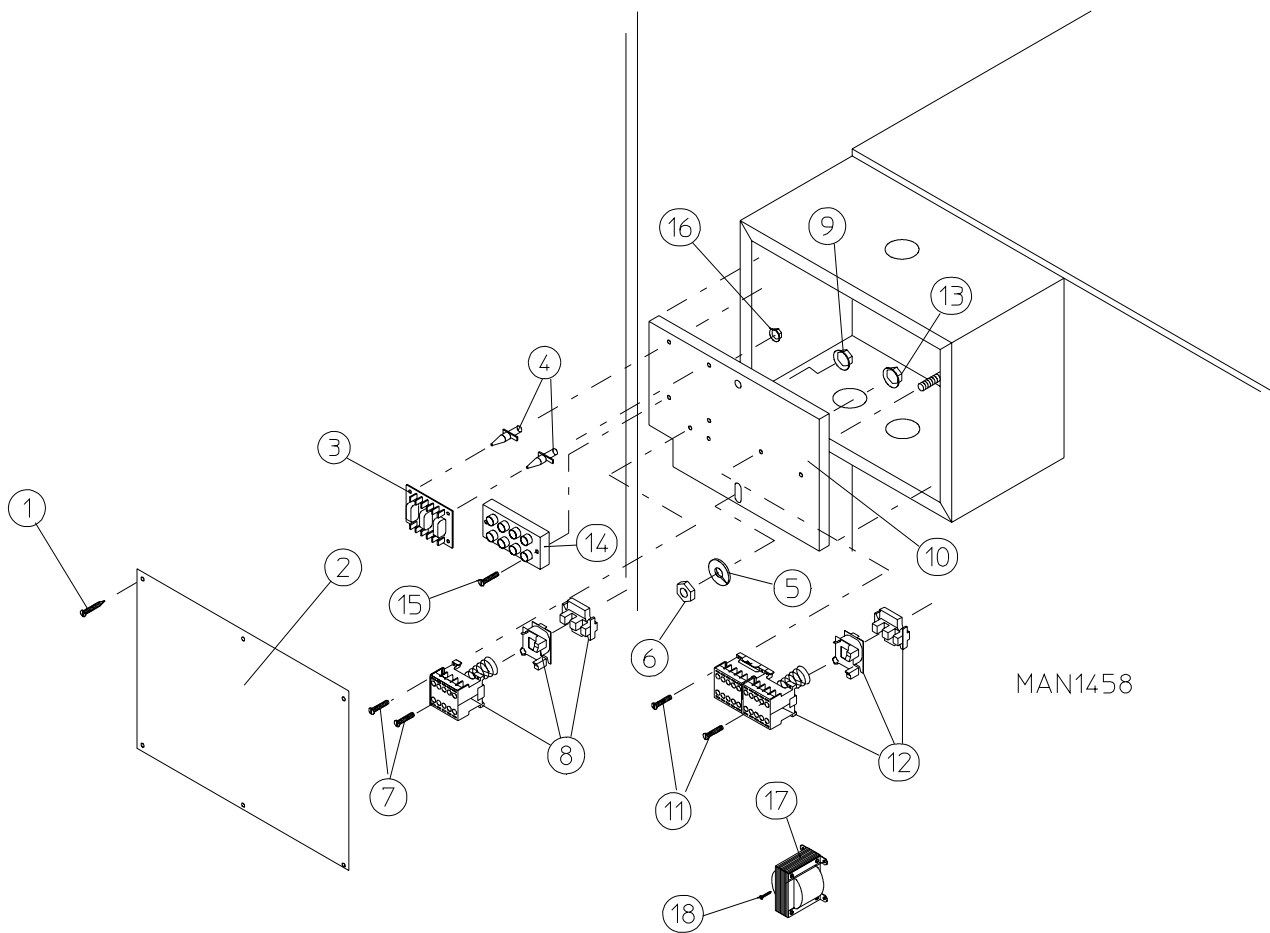

Illus. No.	Part No.	Qty.	Description
1	150301	6	#8-18 x 7/16" Phillips Pan Head TEK Screw
2	322815	1	Control Box Cover Plate ONLY (8-1/2" x 15-1/2")
3	137060	1	Arc Suppressor Board (3)
4	137013	4	Nylon Standoff
5	153002	2	5/16" Lock Washer
6	152004	2	5/16-18 Hex Nut
7	150108	4	#8-32 x 1/2" Pan Head Machine Screw
8	132445	1	3 HP Impellor (fan/blower) Contactor
9	151001	2	#8-32 Pal Nut
10	322816	1	Contactor Mounting Panel ONLY (7" x 15-1/2")
11	150108	4	#8-32 x 1/2" Pan Head Machine Screw
12	132431	1	Reversing (Impellor/Blower/Fan) Contactor -24 VAC
13	132432	1	Contactor Replacement Coil - 24 VAC
14	151001	4	#8-32 Pal Nut
15	120704	1	3-Position Power Distribution Block
16	150108	2	#8-32 x 1/2" Pan Head Machine Screw
17	-----	--	Trnsformer (refer to AD-115 Step Down Transformer Usage Listing on page 50)
18	150300	2	#10 x 1/2" Hex Washer TEK Screw

for Electric Models mfd. as of March 29, 1995

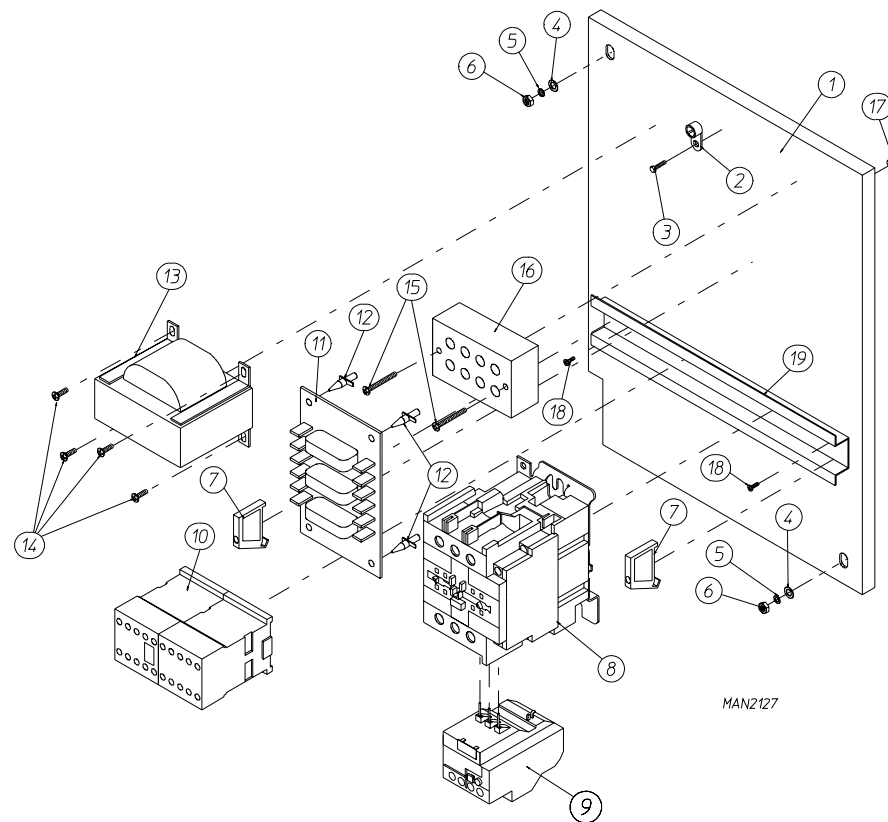

Illus. No.	Part No.	Qty.	Description
1	332344	1	ADE-115 Contactor/Relay Mounting Panel ONLY
2	121010	1	L-70 Ground Lug
3	150108	1	#8-32 x 1/2" Pan Head Machine Screw
4	153001	2	5/16" Flat Washer
5	153002	2	5/16" Lock Washer
6	152004	2	#5/16-18 Hex Nut
7	120765	2	End Stop/Bracket
8	132445	1	3 HP Impellor (Blower/Fan) Contactor
9	132467	1	208 Volt Blower Overload
			(for use on models mfd. for 208/230/240 Volt Electric Service)
	132468	1	380 Volt Blower Overload
			(for use on models mfd. for 380/460/480/575/600 Volt Electric Service)
10	132431	1	Reversing (Impllor/Blower/Fan) Contactor - 24 VAC
	132432	1	Contactor Replacement Coil - 24 VAC
11	137060	1	Arc Suppressor Board (3)
12	137013	4	Nylon Standoff
13	-----	1	Step Down Transformer
			(refer to AD-115 Step Down Transformer Usage Listing on page 50)
14	150300	4	#10 x 1/2" Hex Washer TEK Screw
15	150008	2	#6-32 x 1-1/4" Slotted Round Head Machine Screw
16	120701	1	4-Position Power Distribution Block
17	151000	2	#6-32 Pal Nut
18	150309	2	#10-16 x 1/2" Hex Head TEK Crimptite Screw
19	120768	1	8-1/2" Din Mounting Rail

for Gas and Steam Models, and for Electric Models mfd. prior to March 29, 1995

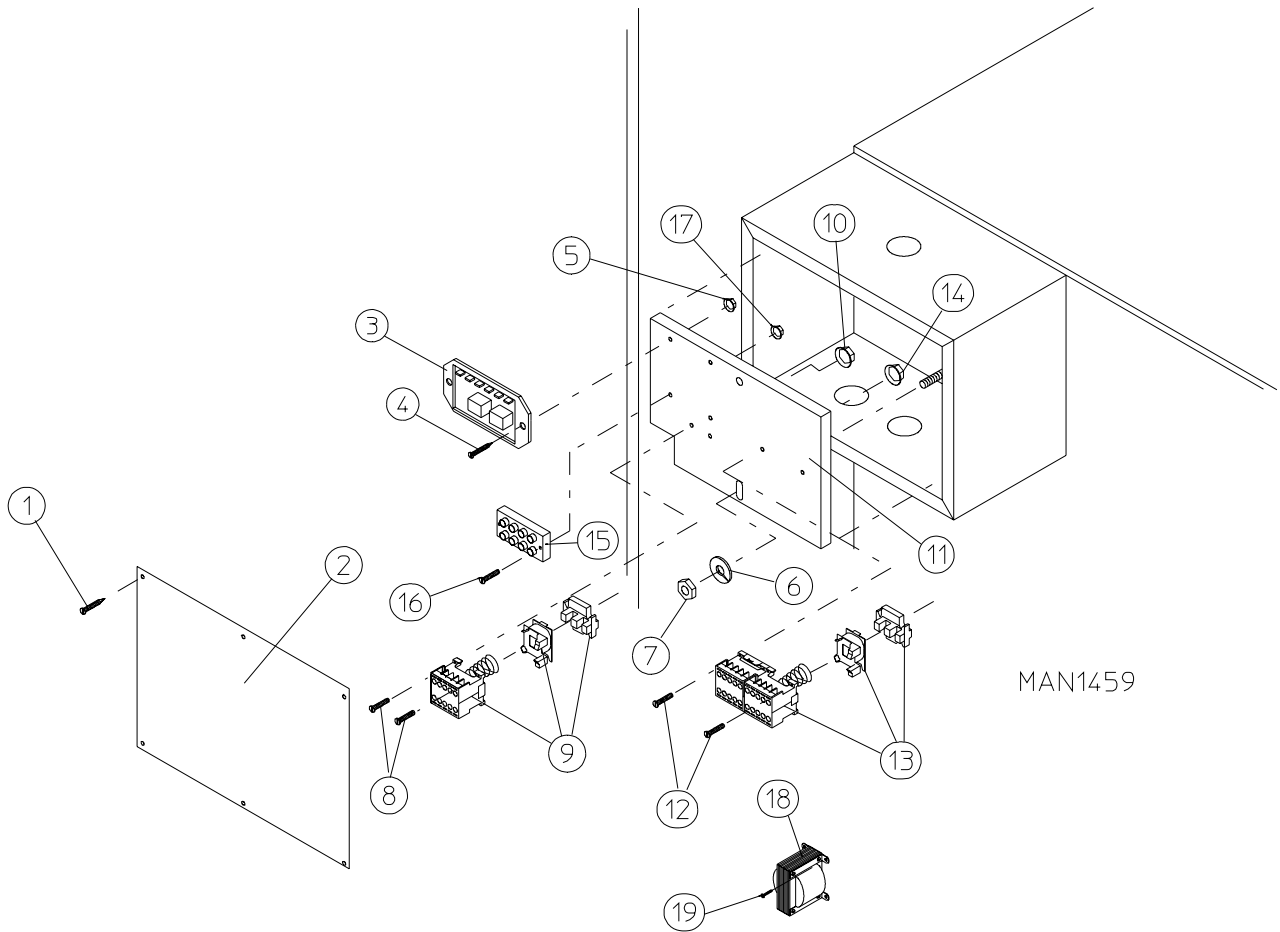

Illus. No.	Part No.	Qty.	Description
1	150301	6	#8-18 x 7/16" Phillips Pan Head TEK Screw
2	322815	1	Control Box Cover Plate ONLY (8-1/2" x 15-1/2")
3	132198	1	Reversing Timer ONLY (50/60 Hz) - 24 VAC
4	150108	2	#8-18 x 1/2" Pan Head Machine Screw
5	151001	2	#8-32 Pal Nut
6	153002	2	5/16" Lock Washer
7	152004	2	5/16-18 Hex Nut
8	150108	4	#8-32 x 1/2" Pan Head Machine Screw
9	132445	1	3 HP Impellor (Blower/Fan) Contactor
10	151001	4	#8-32 Pal Nut
11	322816	1	Contactor Mounting Panel ONLY (7" x 15-1/2")
12	150108	4	#8-32 x 1/2" Pan Head Machine Screw
13	132431	1	Reversing (Impellor/Blower/Fan) Contactor - 24 VAC
	132432	1	Contactor Replacement Coil - 24 VAC
14	151001	4	#8-32 Pal Nut
15	120704	1	3-Position Power Distribution Block
16	150108	2	#8-18 x 1/2" Pan Head Machine Screw
17	151001	2	#8-32 Pal Nut
18	-----	--	Transformer (refer to AD-115 Step Down Transformer Usage Listing on page 50)
19	150300	2	#10 x 1/2" Hex Washer TEK Screw

for Electric Models mfd. as of March 29, 1995

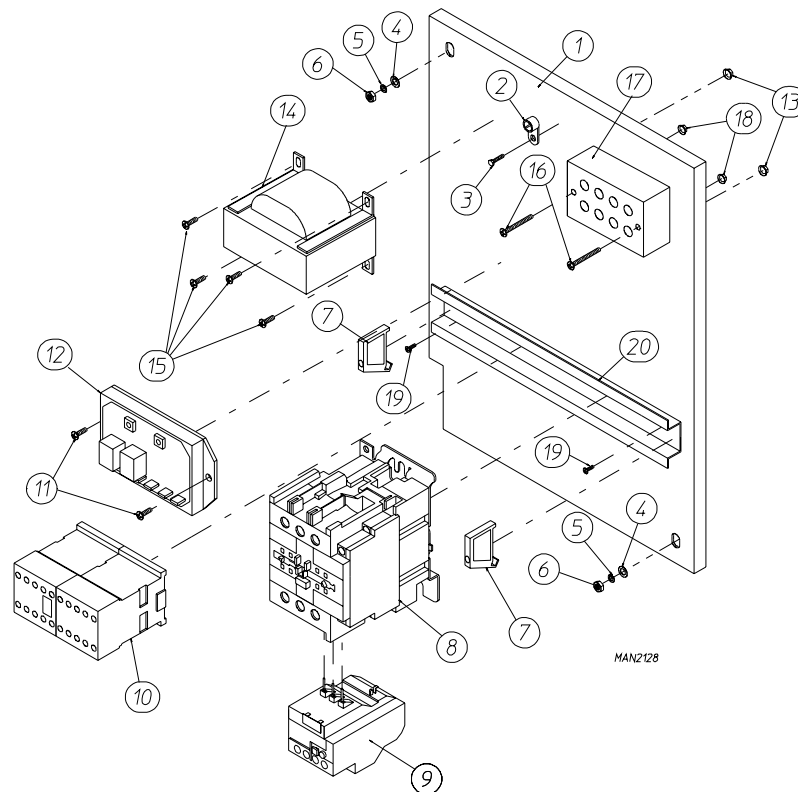

Illus. No.	Part No.	Qty.	Description
1	332344	1	ADE-115 Contactor/Relay Mounting Panel ONLY
2	121010	1	L-70 Ground Lug
3	150108	1	#8-32 x 1/2" Pan Head Machine Screw
4	153001	2	5/16" Flat Washer
5	153002	2	5/16" Lock Washer
6	152004	2	#5/16-18 Hex Nut
7	120765	2	End Stop/Bracket
8	132445	1	3 HP Impellor (Blower/Fan) Contactor
9	132467	1	208 Volt Blower Overload
			(for use on models mfd. for 208/230/240 Volt Electric Service)
	132468	1	380 Volt Blower Overload
			(for use on models mfd. for 380/460/480/575/600 Volt Electric Service)
10	132431	1	Reversing (Impellor/Blower/Fan) Contactor - 24 VAC
	132432	1	Contactor Replacement Coil - 24 VAC
11	150100	2	#8-32 x 1/2" Phillips Round Head Screw
12	132198	1	Reversing Timer ONLY (50/60 Hz) -24 VAC
13	151001	2	#8-32 Pal Nut
14	-----	1	Step Down Transformer
			(refer to AD-115 Step Down Transformer Usage Listing on page 50)
15	150300	4	#10 x 1/2" Hex Washer TEK Screw
16	150008	2	#6-32 x 1-1/4" Slotted Round Head Machine Screw
17	120701	1	4-Position Power Distribution Block
18	151000	2	#6-32 Pal Nut
19	150309	2	#10-16 x 1/2" Hex Head TEK Crimpite Screw
20	120768	1	8-1/2" Din Mounting Rail

for ALL 60 Hz Models mfd. as of January 26, 1995
for ALL 50 Hz Models mfd. as of January 9, 1995

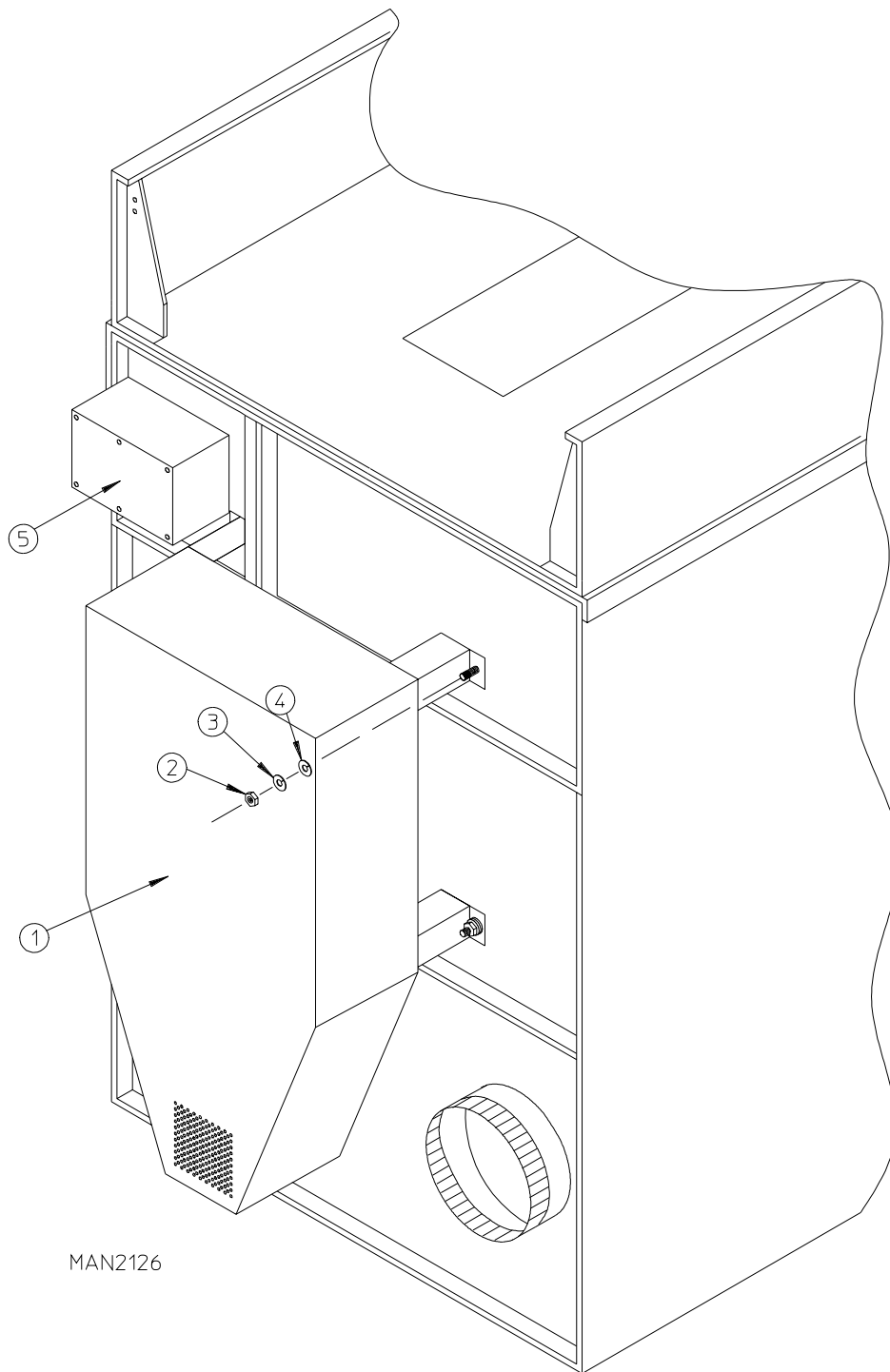

Illus. No.	Part No.	Qty.	Description
1	801510	1	AD-115 Extended Back Guard Assembly
2	152005	4	3/8-16 Hex Nut
3	153005	4	3/8" Lock Washer
4	153004	4	3/8" Flat Washer
5	322815	1	Control Box Cover Plate ONLY (8-1/2" x 15-1/2")

for ALL 60 Hz Models mfd. prior to January 26, 1995

for ALL 50 Hz Models mfd. prior to January 9, 1995

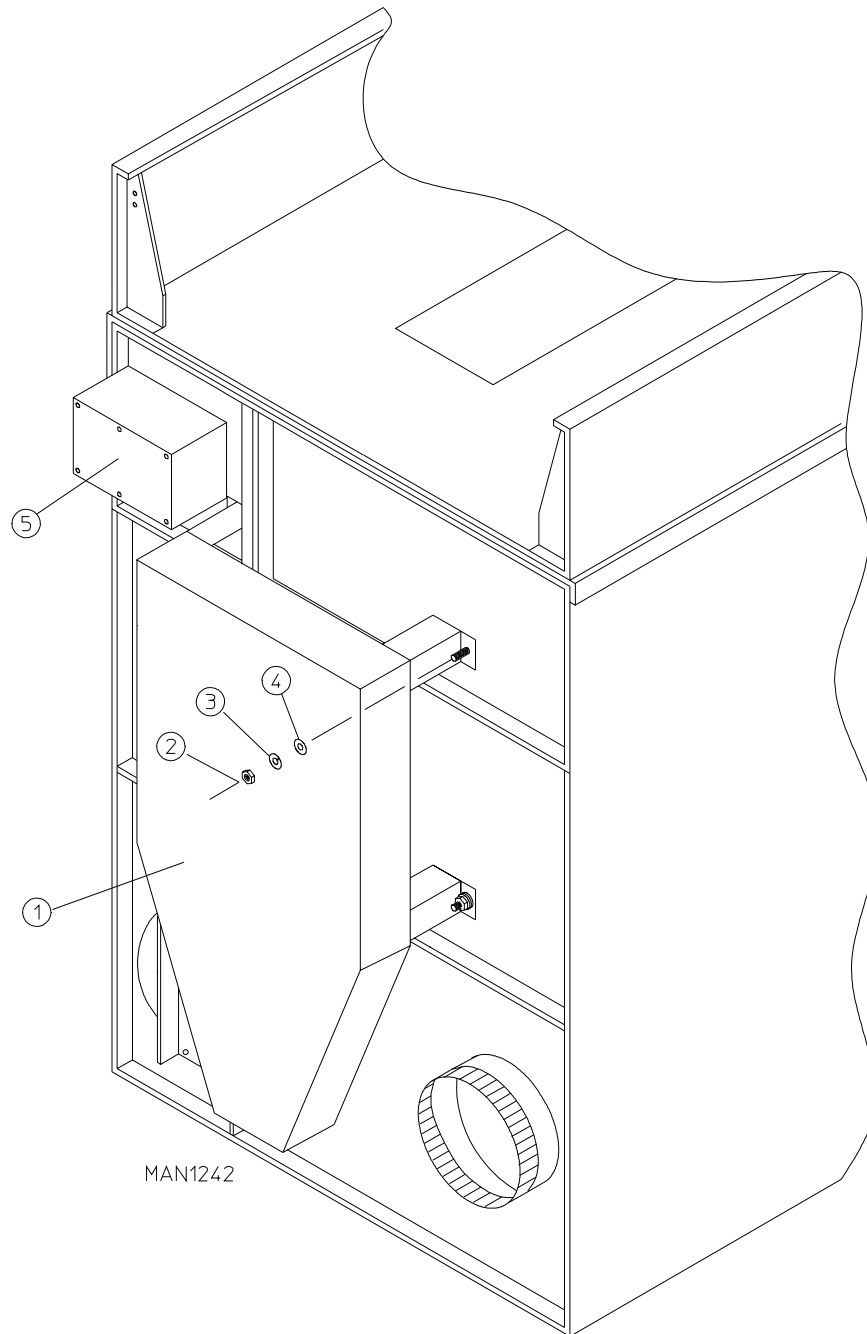

Illus. No.	Part No.	Qty.	Description
1	801509	1	AD-115 Back Guard Assembly
2	162005	4	3/8-16 Hex Nut
3	153005	4	3/8" Lock Washer
4	153004	4	3/8" Flat Washer
5	322815	1	Control Box Cover Plate ONLY (8-1/2" x 15-1/2") (for models mfd. as of January 4, 1993)
	322808	1	Control Box Cover Plate ONLY (8-1/2" x 12") (for models mfd. prior to January 4, 1993)

Step Down Transformer Application Listing (Reversing Relay Box)				
Heat	Voltage	Wire Service	Transformer Part Number	
			Microprocessor Models	Timer Models
Gas / Steam	380	3 or 4	132059	132059
	416	3 or 4	132062	132062
	400	3 or 4	132056	132056
	460/480	3 or 4	132053	132053
	575	3	132050	132050
Electric	380	3 or 4	132059	N/R
	416	3 or 4	132062	N/R
	460/480	3 or 4	132053	N/R
	575	3	N/A	N/A

N/A = Not Available

N/R = Not Required

ADG-115D DSI Burner Orifice Specification*				
Qty.	Natural Gas		L.P. Gas	
	D.M.S.	Part No.	D.M.S.	Part No.
3	#8	140837	#31	140818
* Consult factory for elevations over 2,000 feet.				

ADG-115D DSI Burner Assembly Specification		
Btu/H Rating	Natural Gas	L.P. Gas
343,000	880874	880875
<p>NOTES: 1. Burner assemblies DO NOT include burner orifices. They must be ordered separately.</p> <p>2. When ordering burner assembly, specify model number and serial number of the dryer.</p>		

ADG-115D DSI L.P. Kit Specification*
Kit Part No.
880876
* Consult factory for elevations over 2,000 feet.

for ALLADE-115 with 60 Kw Electric Oven models mfd. as of April 11, 1995

60 Kw Oven	Volts	208		230		380		416		480		
	Phase	3Ø		3Ø		3Ø		3Ø		3Ø		
	Wire	3		3		3 or 4		3 or 4		3 or 4		
	Oven Assy Part No.	815800		815802		815809		815805		815806		
	Elements	Qty.	18		18		18		18		18	
		Size	3.3 Kw		3.3 Kw		3.3 Kw		3.3 Kw		3.3 Kw	
		Part No.	120070		120071		120069		120070		120071	
	Oven Wire	Qty.	51'	9'	51'	9'	22'	8'	22'	8'	22'	8'
		Size	#8	#10	#8	#10	#8	#10	#8	#10	#8	#10
		Part No.	133100	133000	133100	133000	133100	133000	133100	133000	133100	133000
	Terminal Lug	Qty.	18		18		9		9		9	
		Part No.	121010		121010		121010		121010		121010	
Bus Bar Part No. 121011	2'		2'		3'		3'		3'			

for ALLADE-115 with 60 Kw Electric Oven models mfd. prior to April 11, 1995

60 Kw Oven	Volts	208		230		380		416		480		
	Phase	3Ø		3Ø		3Ø		3Ø		3Ø		
	Wire	3		3		3 or 4		3 or 4		3 or 4		
	Oven Assy Part No.	815800		815802		815809		815805		815806		
	Elements	Qty.	12	6	12	6	12	6	12	6	12	6
		Size	3 Kw	4 Kw	3 Kw	4 Kw	3 Kw	4 Kw	3 Kw	4 Kw	3 Kw	4 Kw
		Part No.	120006	120008	120007	120009	120006	120008	120006	120008	120007	120009
	Oven Wire	Qty.	51'	9'	51'	9'	22'	8'	22'	8'	22'	8'
		Size	#8	#10	#8	#10	#8	#10	#8	#10	#8	#10
		Part No.	133100	133000	133100	133000	133100	133000	133100	133000	133100	133000
	Terminal Lug	Qty.	18		18		9		9		9	
		Part No.	121010		121010		121010		121010		121010	
Bus Bar Part No. 121011	2'		2'		3'		3'		3'			

NOTE: Oven Wire and Bus Bar are sold in feet.

72 Kw Oven	Volts	208		230		380		416		480		600		
	Phase	3Ø		3Ø		3Ø		3Ø		3Ø		32		
	Wire	3		3		3 or 4		3 or 4		3 or 4		3 or 4		
	Oven Assy Part No.	815816		815817		815820		815821		815822		815828		
	Elements	Qty.	18		18		18		18		18		18	
		Size	4 Kw		4 Kw		4 Kw		4 Kw		4 Kw		4 Kw	
		Part No.	120008		120009		120044		120008		120009		120028	
	Oven Wire	Qty.	6'	25'	6'	25'	3'	8'	3'	25'	3'	25'	6'	25'
		Size	2	8	2	8	2	8	2	8	2	8	8	10
		Part No.	133302	133100	133302	133100	133302	133100	133002	133100	133302	133100	13310	133000
	Terminal Lug	Qty.	13	6	13	6	9	1	9	1	9	1	13	6
		Part No.	121010	121012	121010	121012	121010	121012	121010	121012	121010	121012	121010	121012
Bus Bar Part No. 121011	2'		2'		3'		3'		3'		2'			

80 Kw Oven	Volts	208		230		380		416		480		
	Phase	3Ø		3Ø		3Ø		3Ø		3Ø		
	Wire	3		3		3 or 4		3 or 4		3 or 4		
	Oven Assy Part No.	815823		815824		815810		815826		815827		
	Elements	Qty.	18		18		18		18		18	
		Size	4.5 Kw		4.5 Kw		4.5 Kw		4.5 Kw		4.5 Kw	
		Part No.	120047		120048		120022		120047		120048	
	Oven Wire	Qty.	6'	25'	6'	25'	3'	25'	3'	25'	3'	25'
		Size	2	8	2	8	1	8	1	8	2	8
		Part No.	133302	133100	133302	133100	133301	133100	133301	133100	133302	133100
	Terminal Lug	Qty.	18		18		10	1	18	1	18	1
		Part No.	121010		121010		121010	121012	121010	121012	121010	121012
Bus Bar Part No. 121011	8'		8'		11'		11'		11'			

NOTE: Oven Wire and Bus Bar are sold in feet.

for 60 Kw 208/240 VAC Microprocessor models mfd. as of April 11, 1995

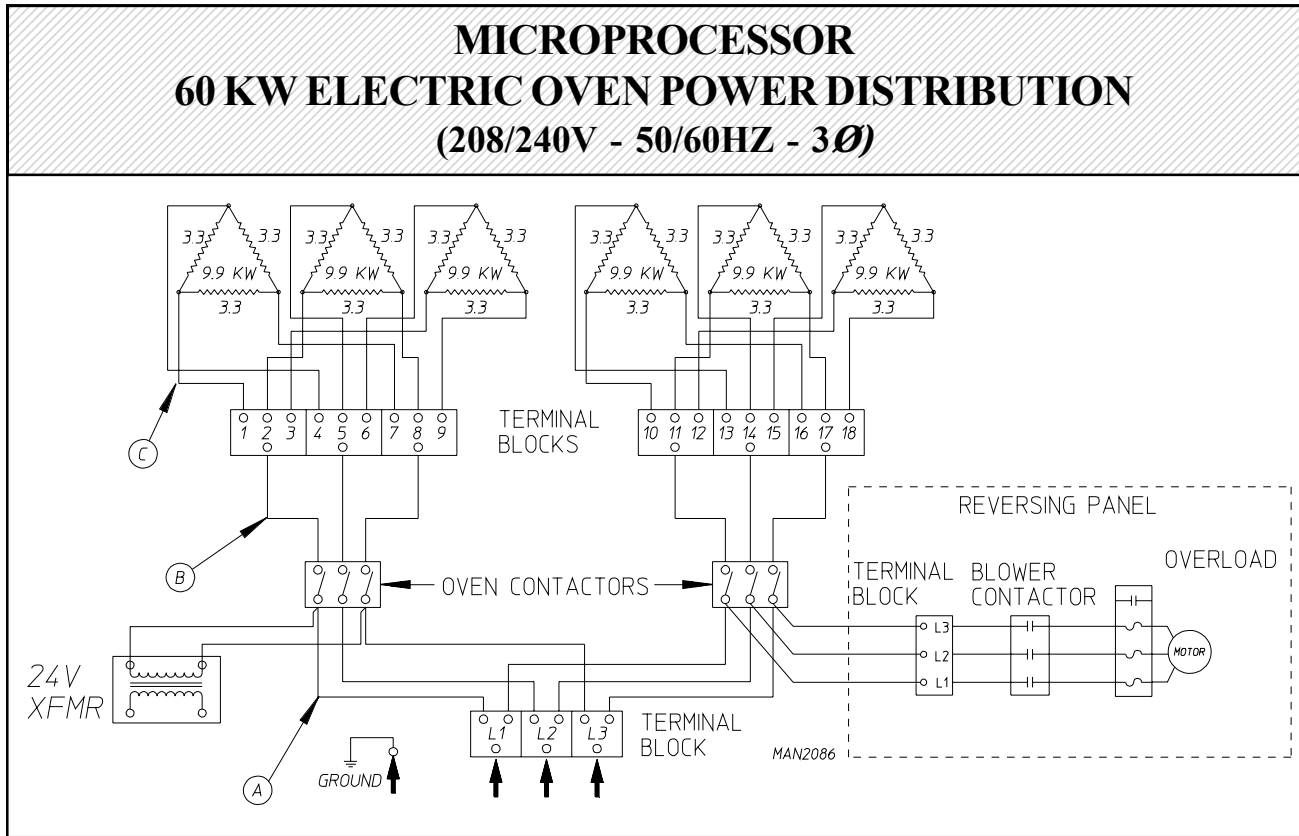

Electric Service	Qty Elements	Element Part Number	Oven Amps	Wire Service			Contactor	24 VAC Step Down Transformer
				A	B	C		
208v 3Ø 3, 4w	18	120070	165	8	8	10	131375	132004
240v 3Ø 3, 4w	18	120071	143	8	8	10	131375	132004

for 60 Kw 416/480 VAC Microprocessor models mfd. as of April 11, 1995

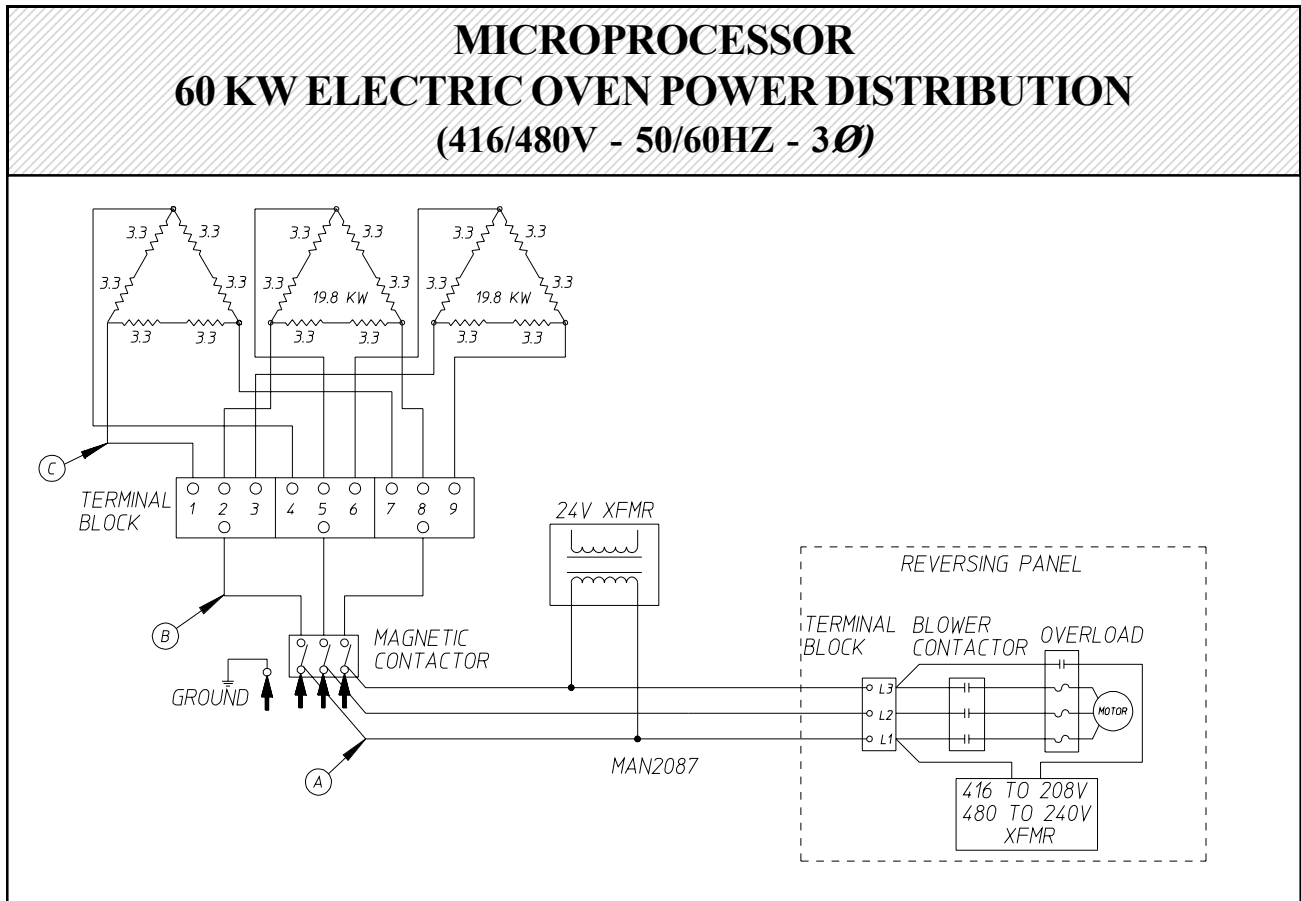

Electric Service	Qty Elements	Element Part Number	Oven Amps	Wire Service			Contactor	24 VAC Step Down Transformer
				A	B	C		
416v 3Ø 3, 4w	18	120070	84	8	8	10	131385	132004
480v 3Ø 3, 4w	18	120071	73	8	8	10	131385	132004

for 60 Kw 208/240 VAC Dual Timer models mfd. as of April 11, 1995

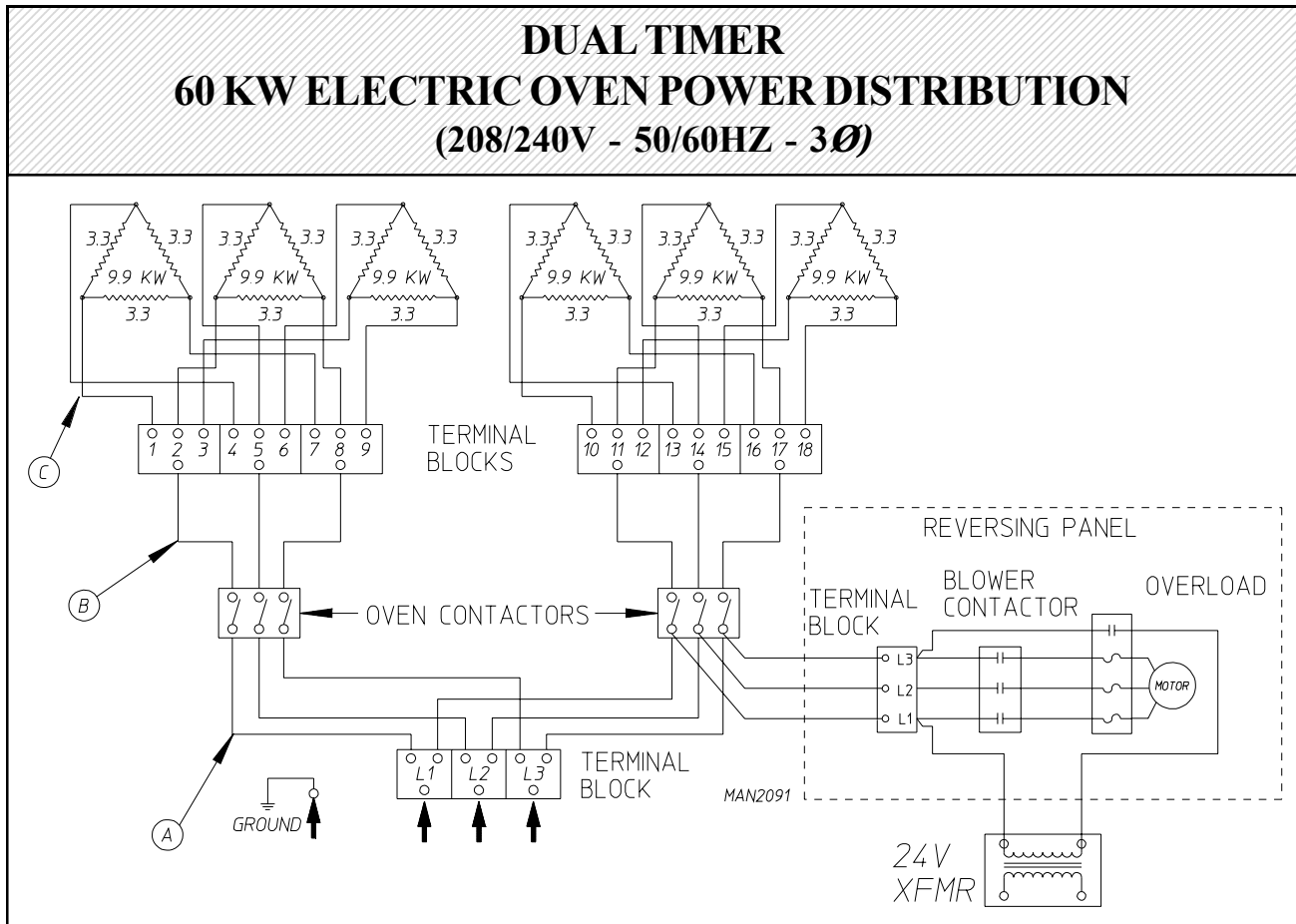

Electric Service	Qty Elements	Element Part Number	Oven Amps	Wire Service			Contactor	24 VAC Step Down Transformer
				A	B	C		
208v 3Ø 3, 4w	18	120070	165	8	8	10	131375	132004
240v 3Ø 3, 4w	18	120071	143	8	8	10	131375	132004

for 60 Kw 416/480 VAC Dual Timer models mfd. as of April 11, 1995

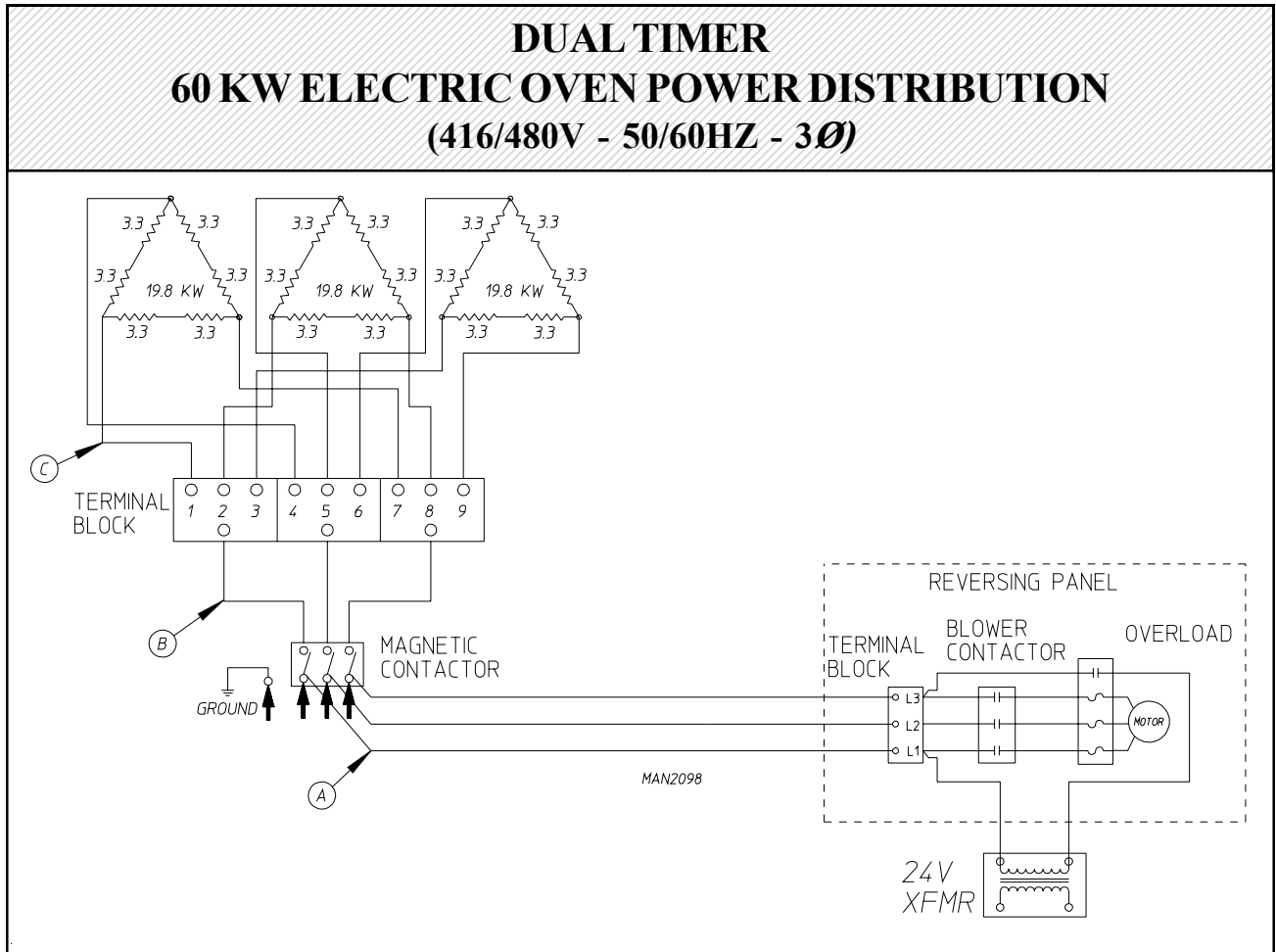

Electric Service	Qty Elements	Element Part Number	Oven Amps	Wire Service			Contactor	24 VAC Step Down Transformer
				A	B	C		
416v 3Ø 3, 4w	18	120070	84	8	8	10	131385	132004
480v 3Ø 3, 4w	18	120071	73	8	8	10	131385	132004

for 60 Kw 208/240 VAC models mfd. prior to April 11, 1995

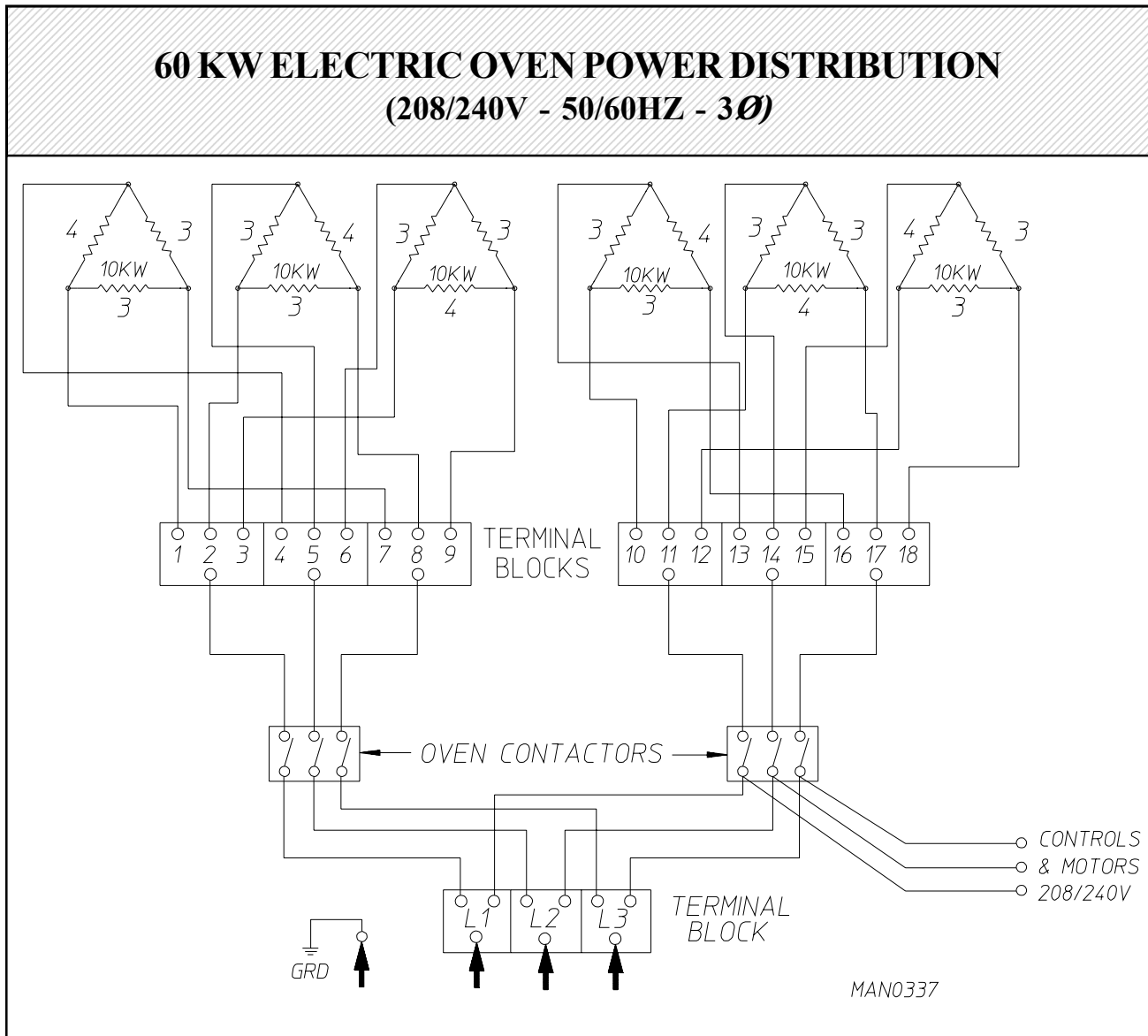

for 60 Kw 416/480 VAC models mfd. prior to April 11, 1995

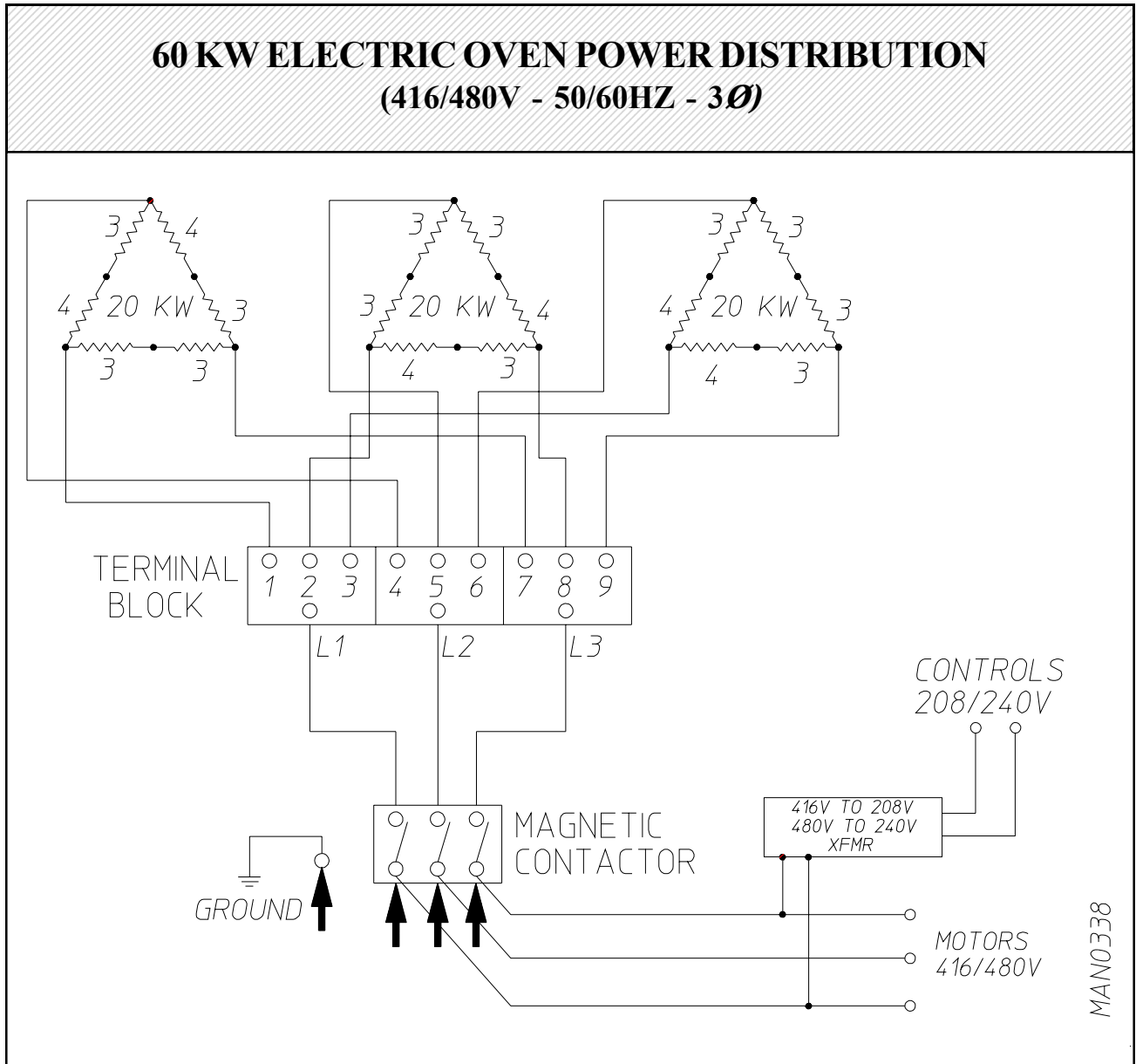

for 72 Kw 208/240 VAC Microprocessor models mfd. as of April 11, 1995

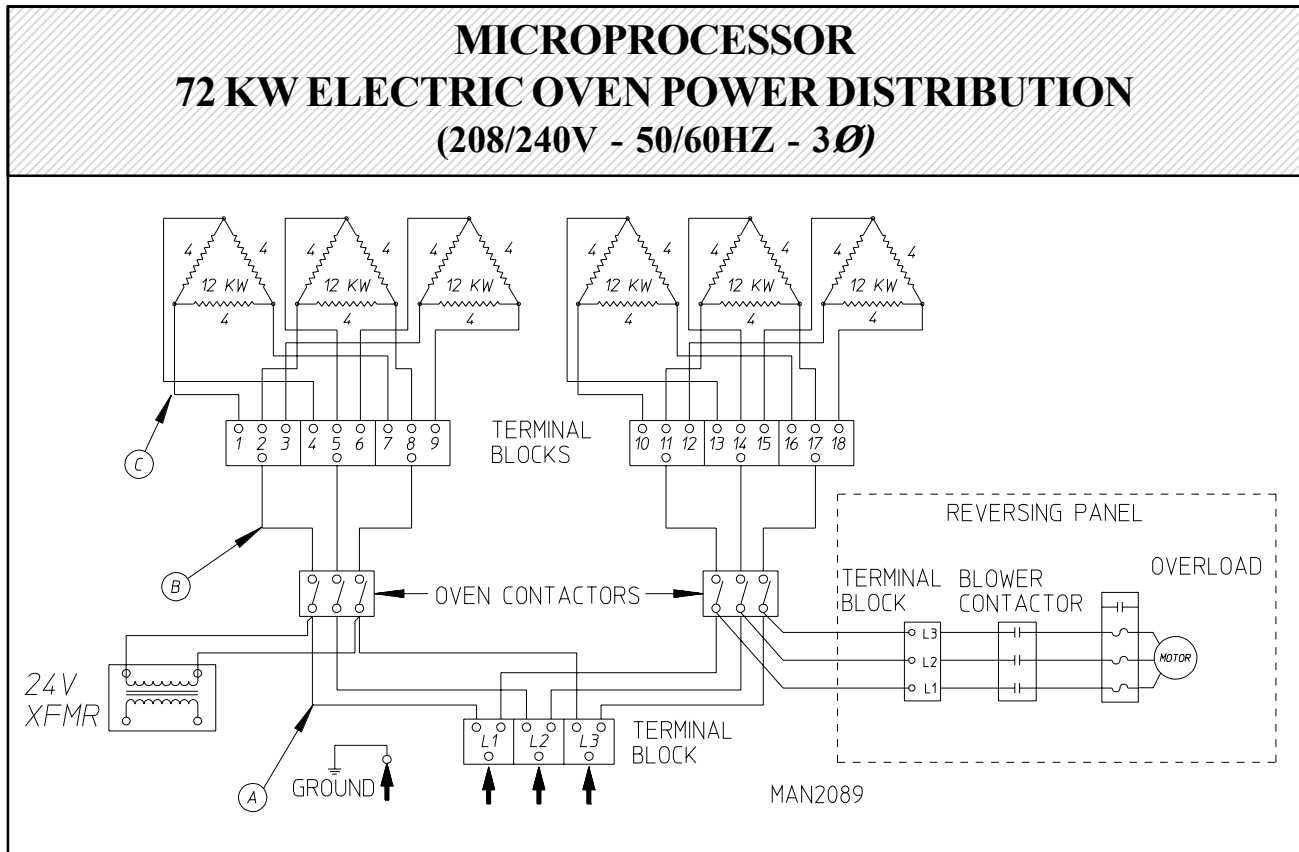

Electric Service	Qty Elements	Element Part Number	Oven Amps	Wire Service			Contactor	24 VAC Step Down Transformer
				A	B	C		
208v 3Ø 3, 4w	18	120008	200	2	2	8	131385	132004
240v 3Ø 3, 4w	18	120009	174	2	2	8	131385	132004

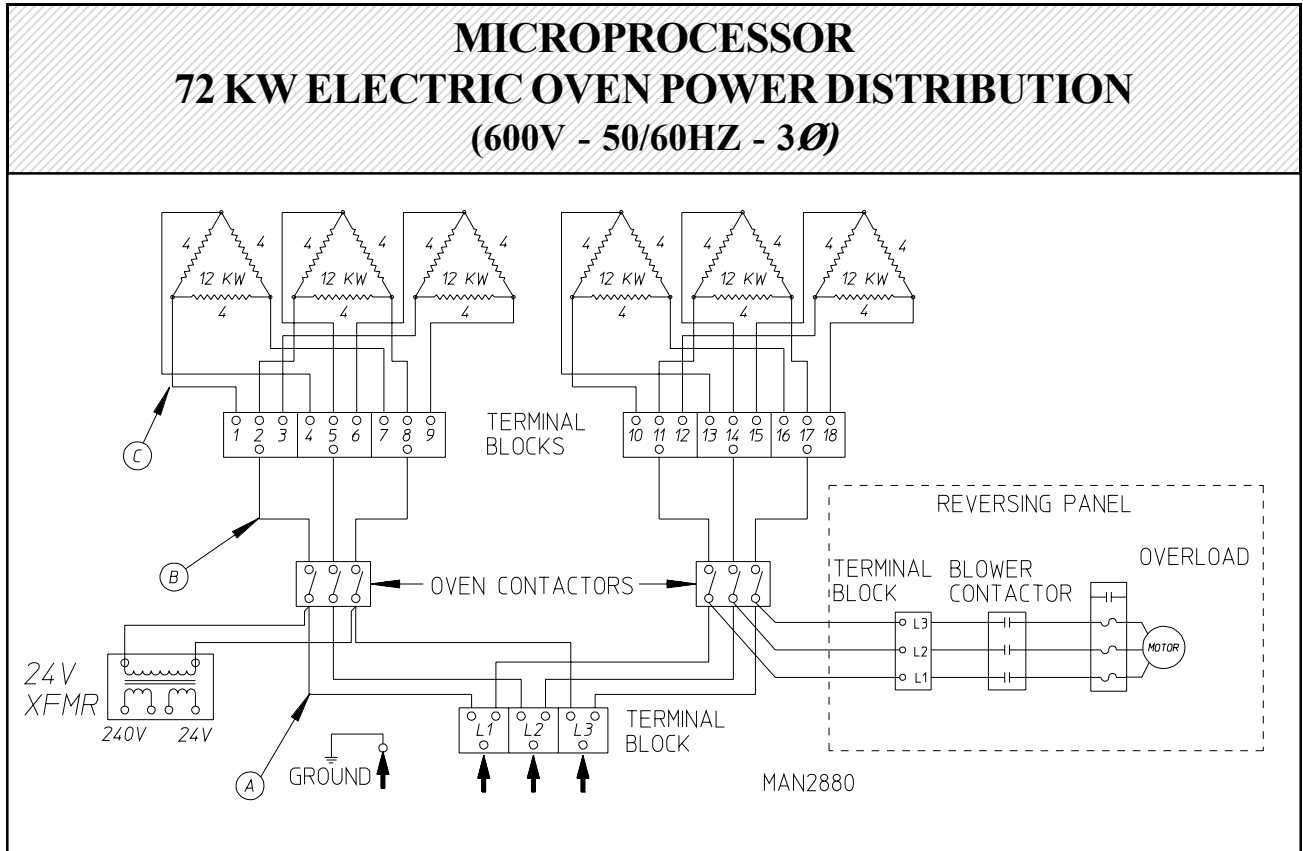

Electric Service	Qty Elements	Element Part Number	Oven Amps	Wire Service			Contactor	24 VAC Step Down Transformer
				A	B	C		
600v 3Ø 3, 4w	18	120028	69	8	8	18	131350	132097

for 72 Kw 380/416/480 VAC Microprocessor models mfd. as of April 11, 1995

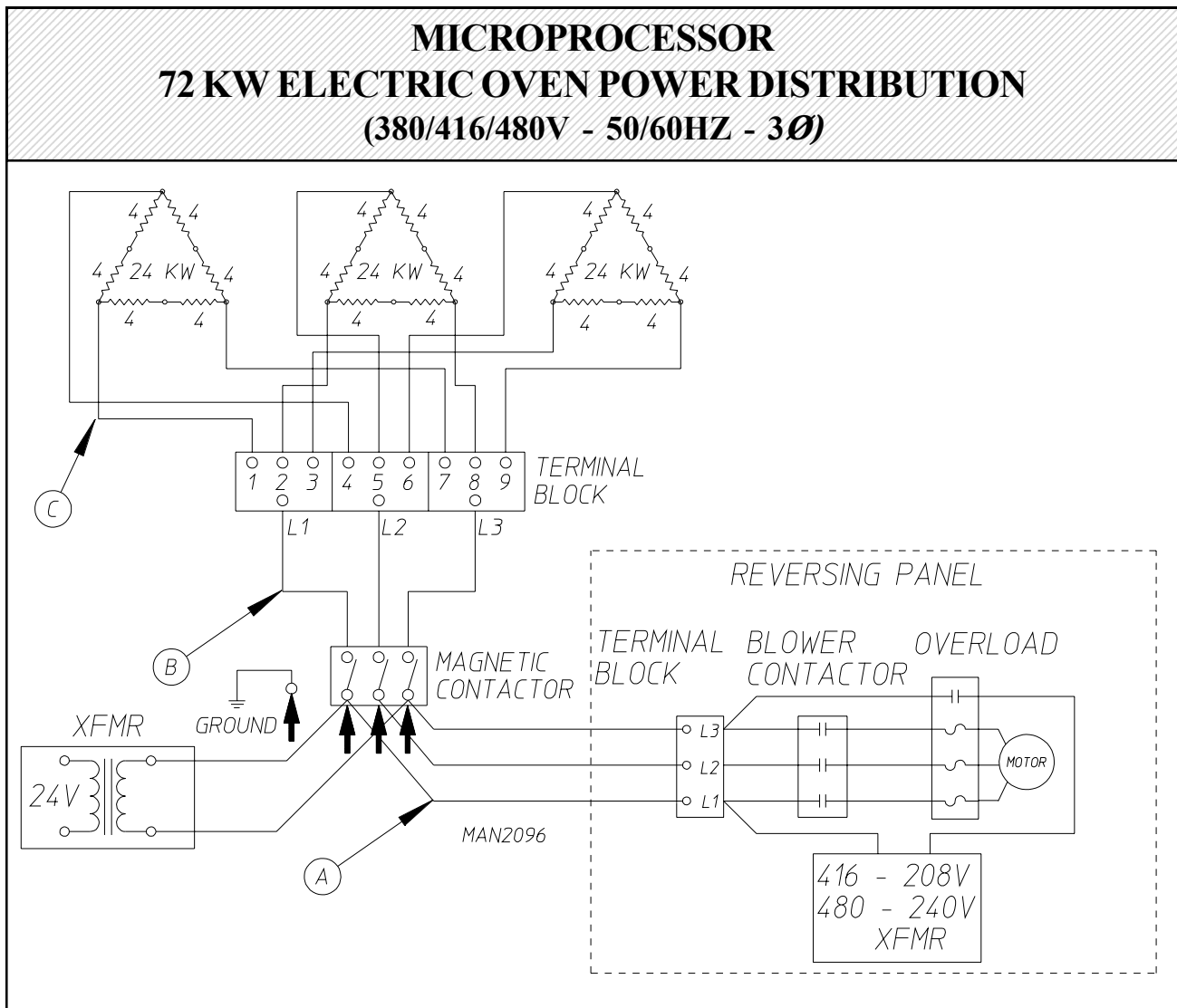

Electric Service	Qty Elements	Element Part Number	Oven Amps	Wire Service		Contactor	24 VAC Step Down Transformer
				A	B		
380v 3Ø 3, 4w	18	120044	110	2	8	131385	132004
416v 3Ø 3, 4w	18	120008	100	2	8	131385	132004
480v 3Ø 3, 4w	18	120009	87	2	8	131385	132004

for 72 Kw 208/240 VAC Dual Timer models mfd. as of April 11, 1995

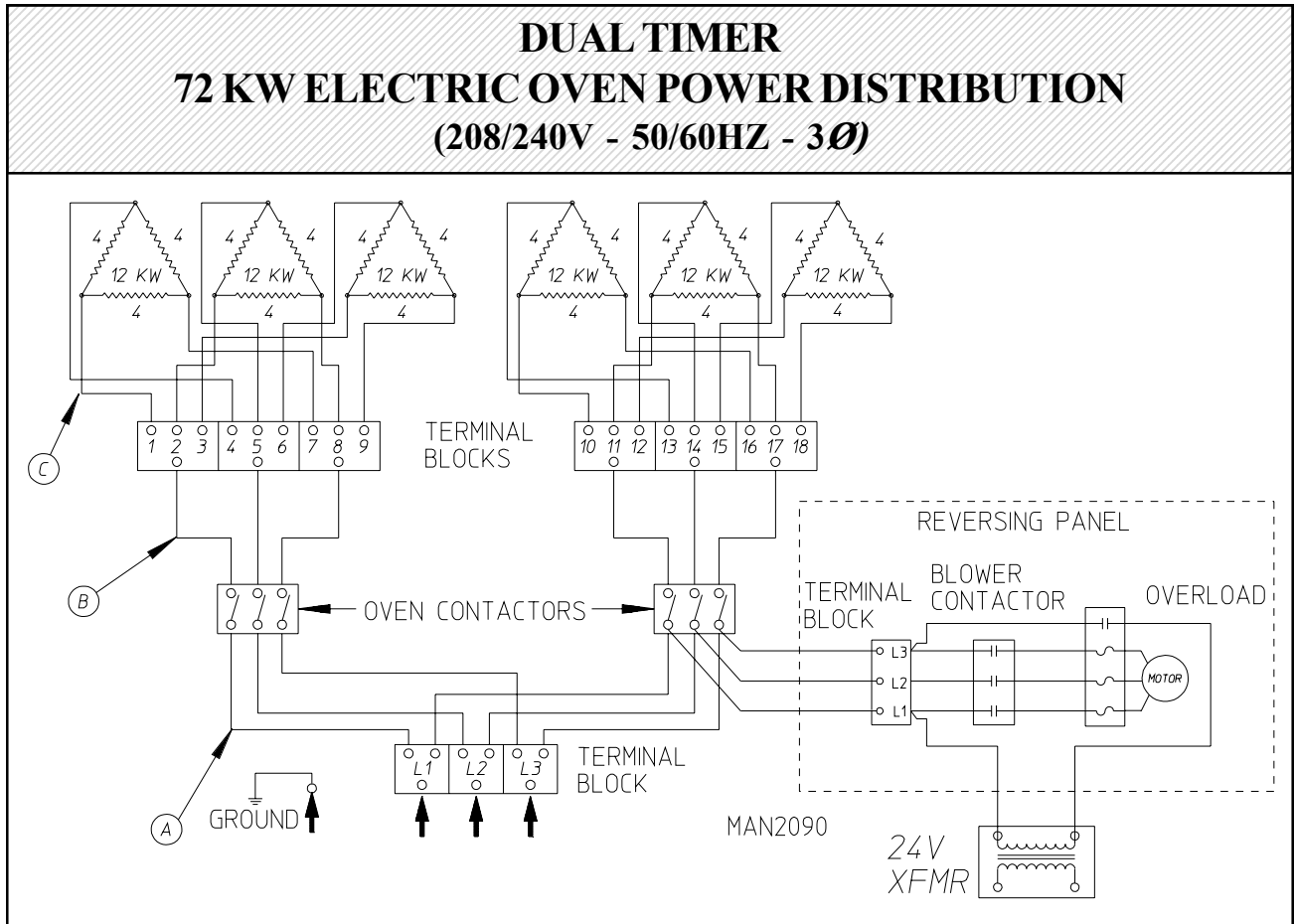

Electric Service	Qty Elements	Element Part Number	Oven Amps	Wire Service			Contactor	24 VAC Step Down Transformer
				A	B	C		
208v 3Ø 3, 4w	18	120008	200	2	2	8	131385	132004
240v 3Ø 3, 4w	18	120009	174	2	2	8	131385	132004

for 72 Kw 380/416/480 VAC Dual Timer models mfd. as of April 11, 1995

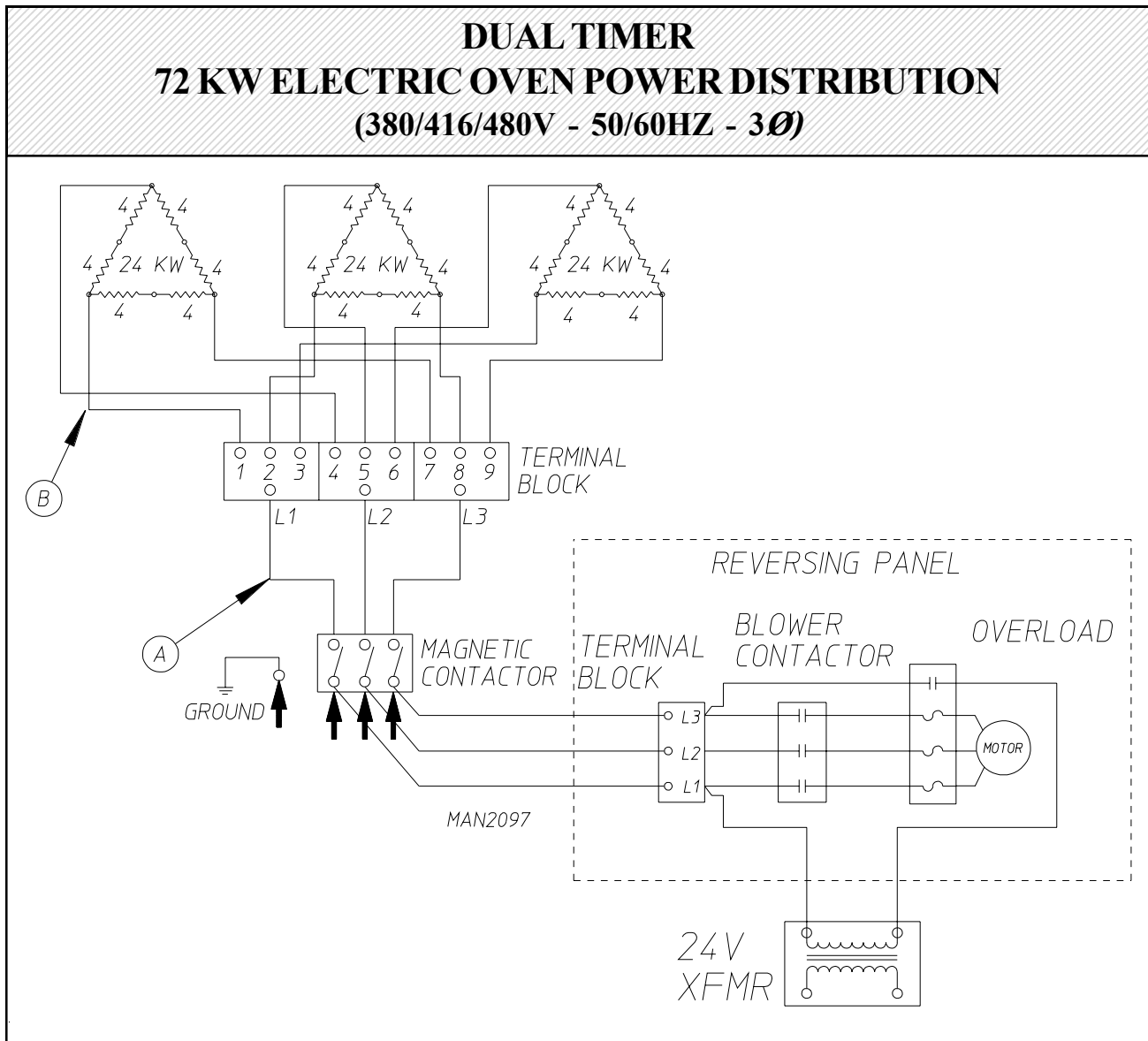

Electric Service	Qty Elements	Element Part Number	Oven Amps	Wire Service		Contactor	24 VAC Step Down Transformer
				A	B		
380v 3Ø 3, 4w	18	120044	110	2	8	131385	132004
416v 3Ø 3, 4w	18	120008	100	2	8	131385	132004
480v 3Ø 3, 4w	18	120009	87	2	8	131385	132004

for 72 Kw 208/240 VAC models mfd. prior to April 11, 1995

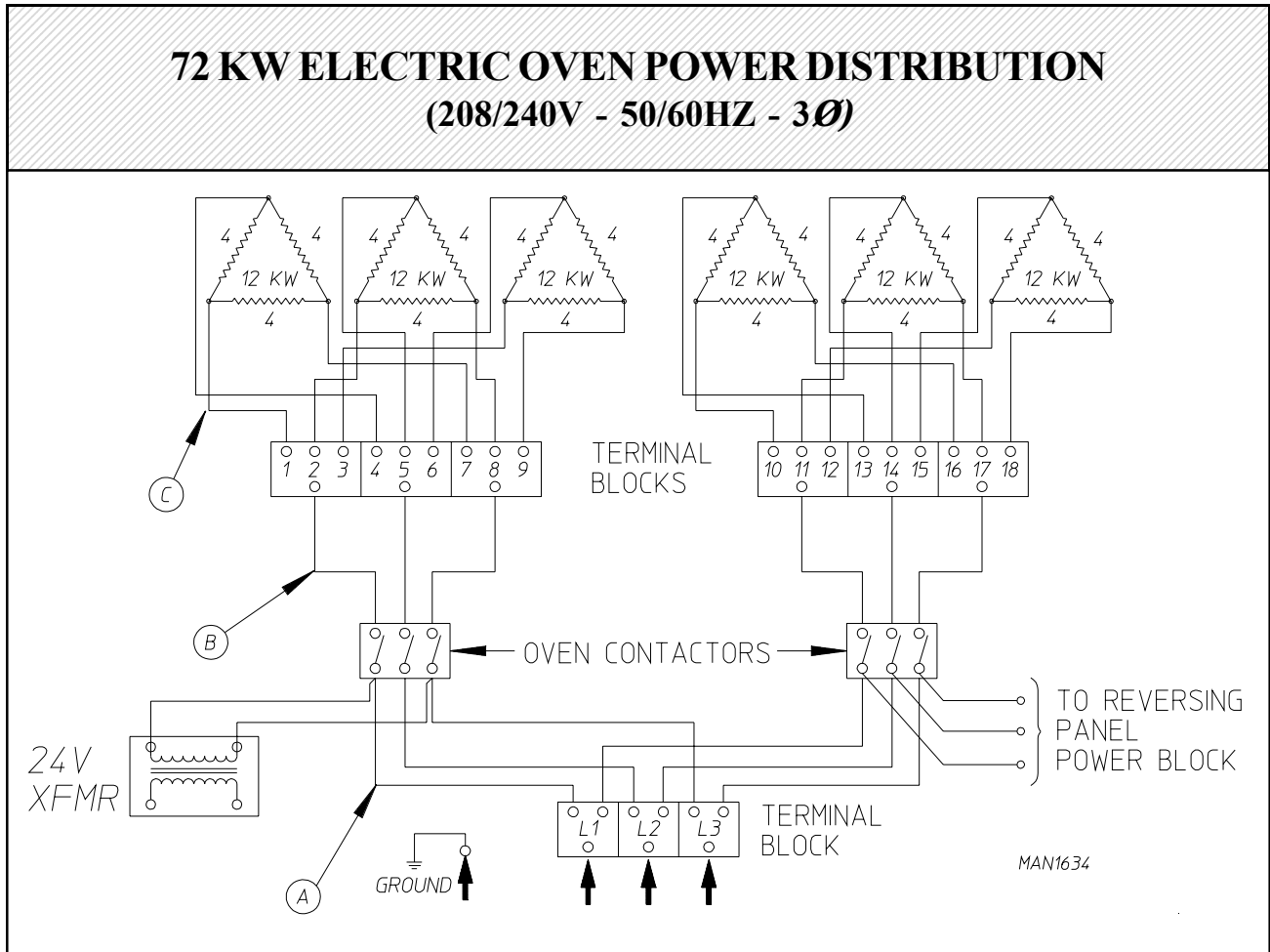

Electric Service	Qty Elements	Element Part Number	Oven Amps	Wire Service			Contactor	24 VAC Step Down Transformer
				A	B	C		
208v 3Ø 3, 4w	18	120008	200	2	2	8	131385	132004
240v 3Ø 3, 4w	18	120009	174	2	2	8	131385	132004

for 72 Kw 380/416/480 VAC models mfd. as of April 11, 1995

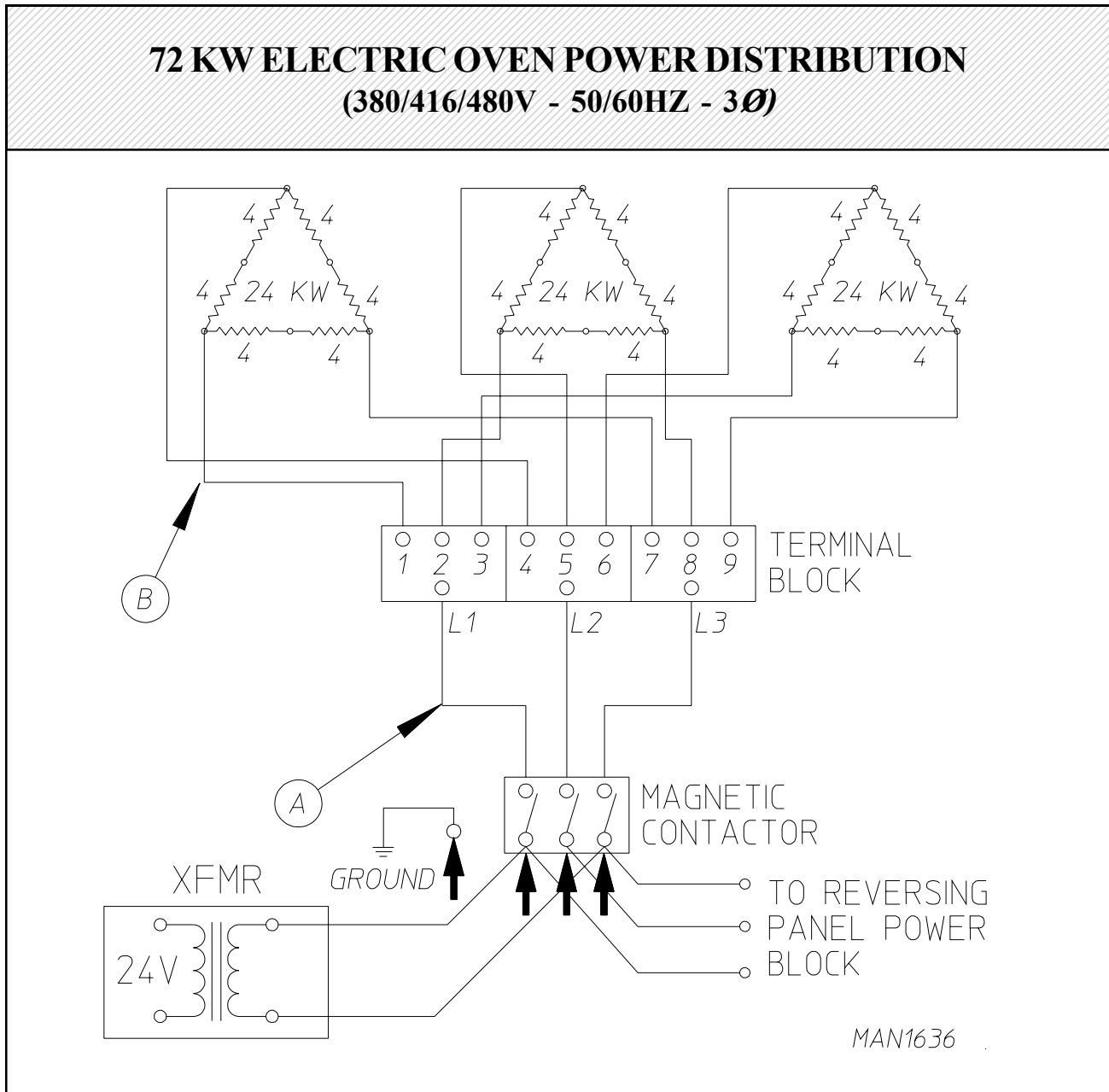

Electric Service	Qty Elements	Element Part Number	Oven Amps	Wire Service		Contactor	24 VAC Step Down Transformer
				A	B		
380v 3Ø 3, 4w	18	120044	110	2	8	131385	132004
416v 3Ø 3, 4w	18	120008	100	2	8	131385	132004
480v 3Ø 3, 4w	18	120009	87	2	8	131385	132004

for 80 Kw 208/240 VAC Microprocessor models mfd. as of April 11, 1995

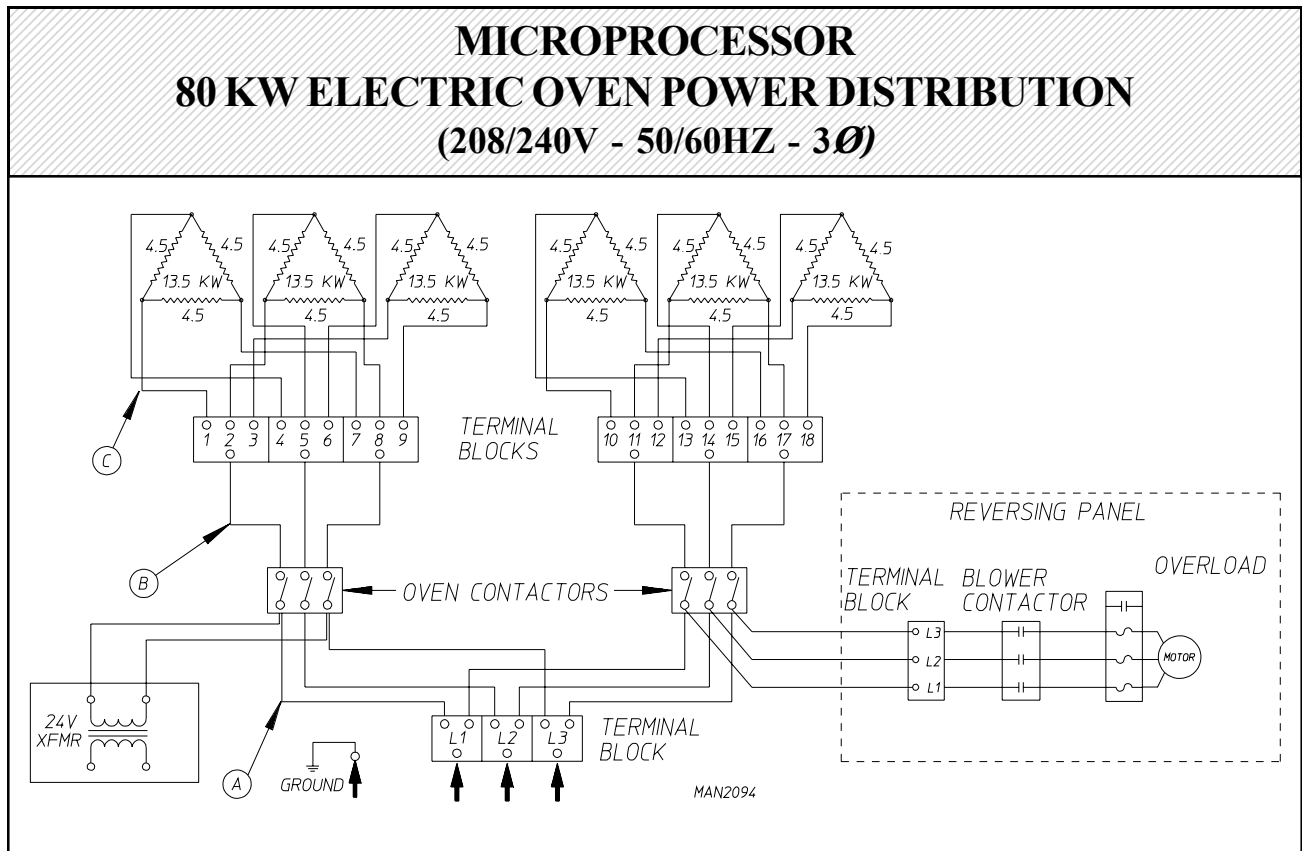

Electric Service	Qty Elements	Element Part Number	Oven Amps	Wire Service			Contactor	24 VAC Step Down Transformer
				A	B	C		
208v 3Ø 3, 4w	18	120047	222	2	2	8	131385	132004
240v 3Ø 3, 4w	18	120048	193	2	2	8	131385	132004

for 80 Kw 380/416/480 VAC Microprocessor models mfd. as of April 11, 1995

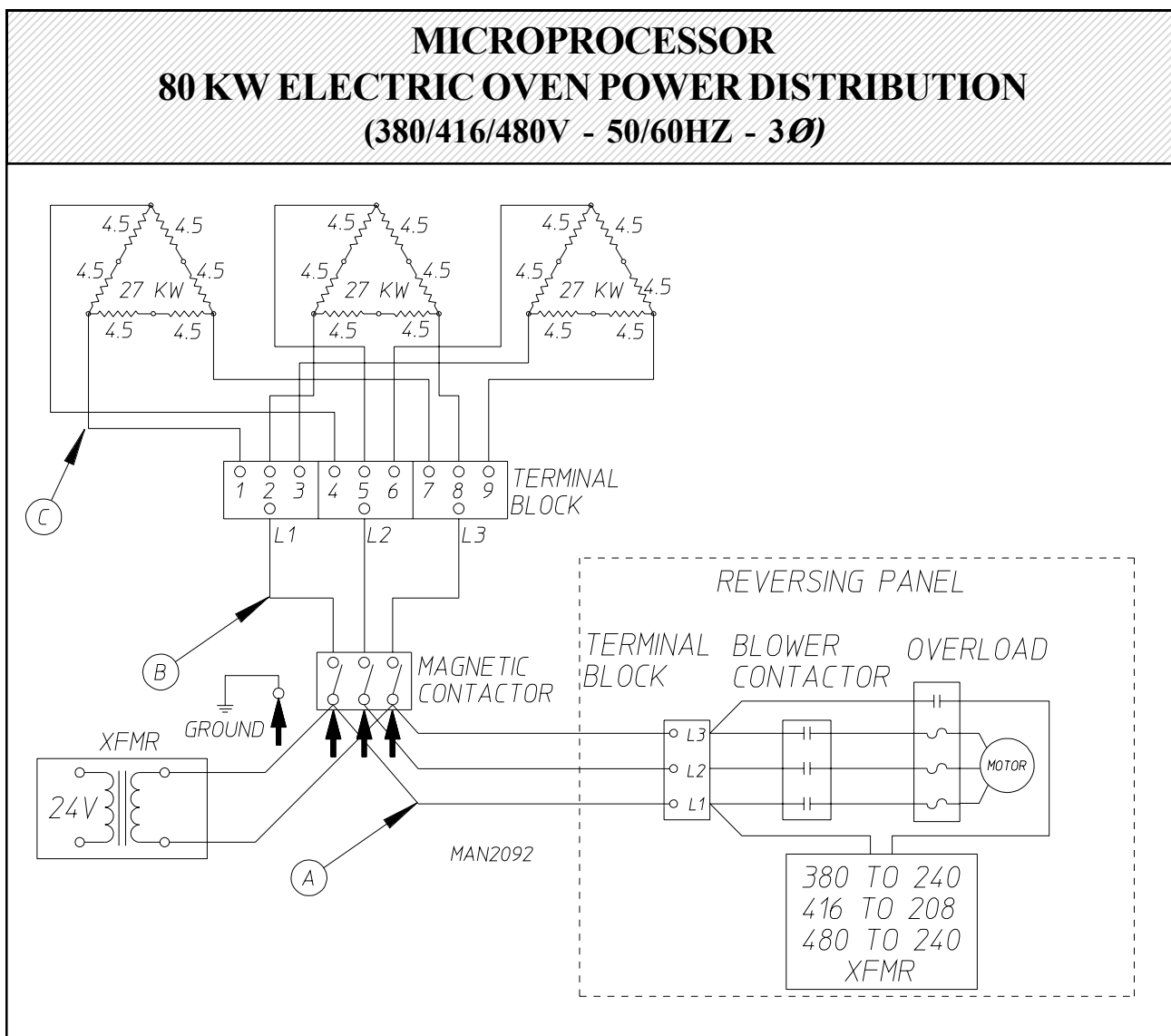

Electric Service	Qty Elements	Element Part Number	Oven Amps	Wire Service		Contactor	24 VAC Step Down Transformer
				A	B		
380v 3Ø 3, 4w	18	120022	122	1	8	131385	132004
416v 3Ø 3, 4w	18	120047	111	1	8	131385	132004
480v 3Ø 3, 4w	18	120048	96.3	2	8	131385	132004

for 80 Kw 208/240 VAC Dual Timer models mfd. as of April 11, 1995

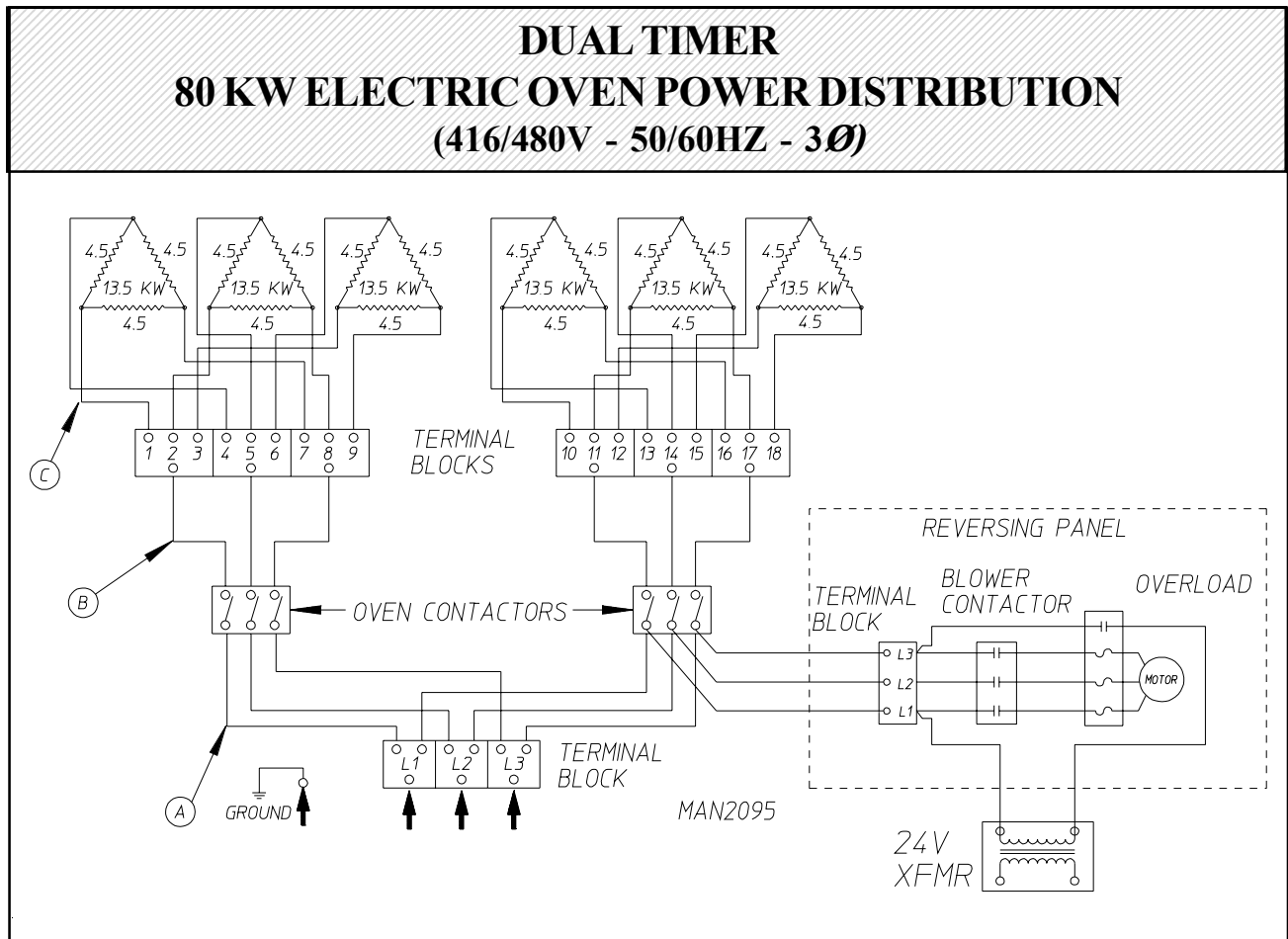

Electric Service	Qty Elements	Element Part Number	Oven Amps	Wire Service			Contactor	24 VAC Step Down Transformer
				A	B	C		
208v 3Ø 3, 4w	18	120047	222	2	2	8	131385	132004
240v 3Ø 3, 4w	18	120048	193	2	2	8	131385	132004

for 80 Kw 380/416/480 VAC Dual Timer models mfd. as of April 11, 1995

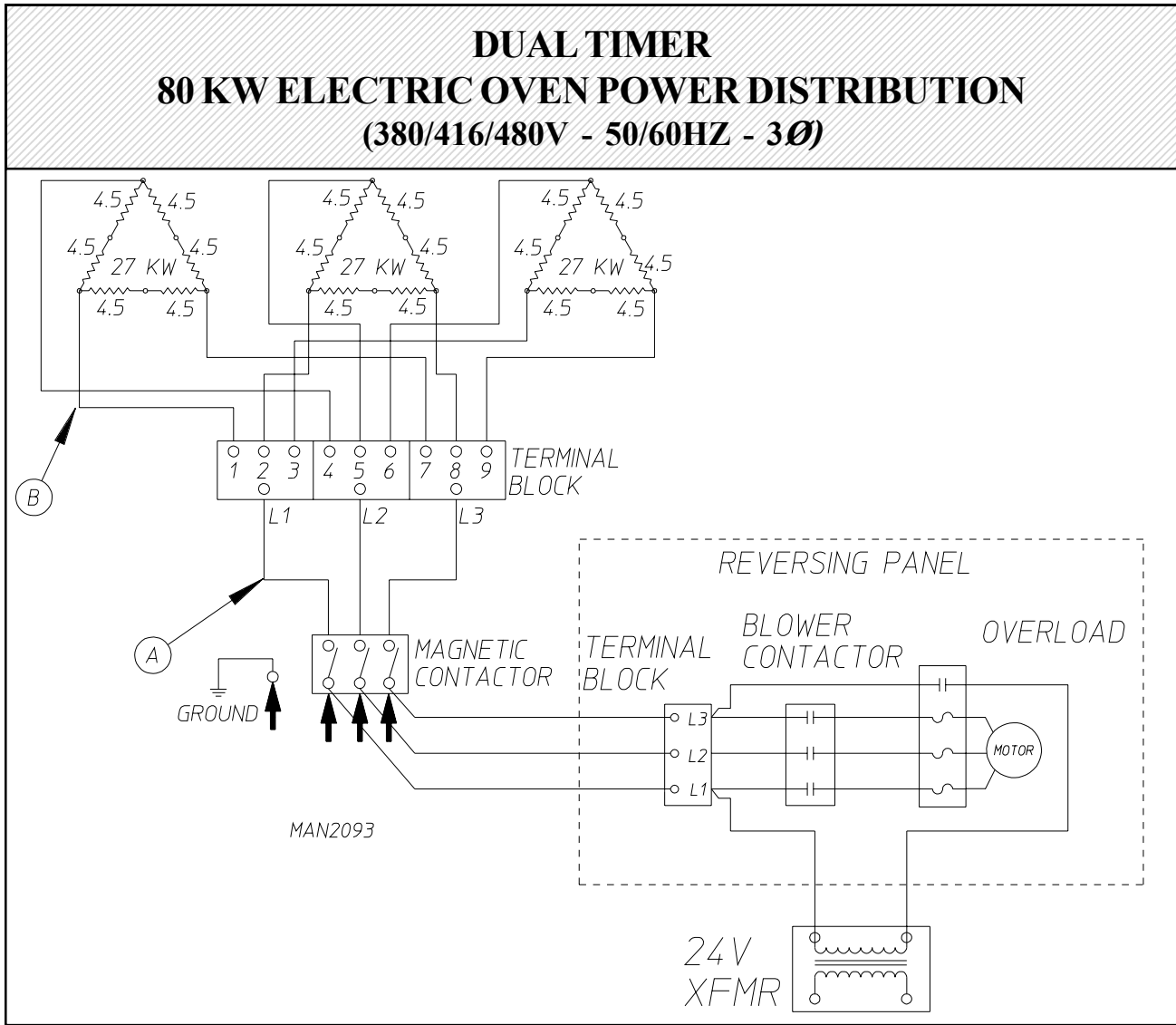

Electric Service	Qty Elements	Element Part Number	Oven Amps	Wire Service		Contactor	24 VAC Step Down Transformer
				A	B		
380v 3Ø 3, 4w	18	120022	122	1	8	131385	132004
416v 3Ø 3, 4w	18	120047	111	1	8	131385	132004
480v 3Ø 3, 4w	18	120048	96.3	2	8	131385	132004

for 80 Kw 208/240 VAC models mfd. prior to April 11, 1995

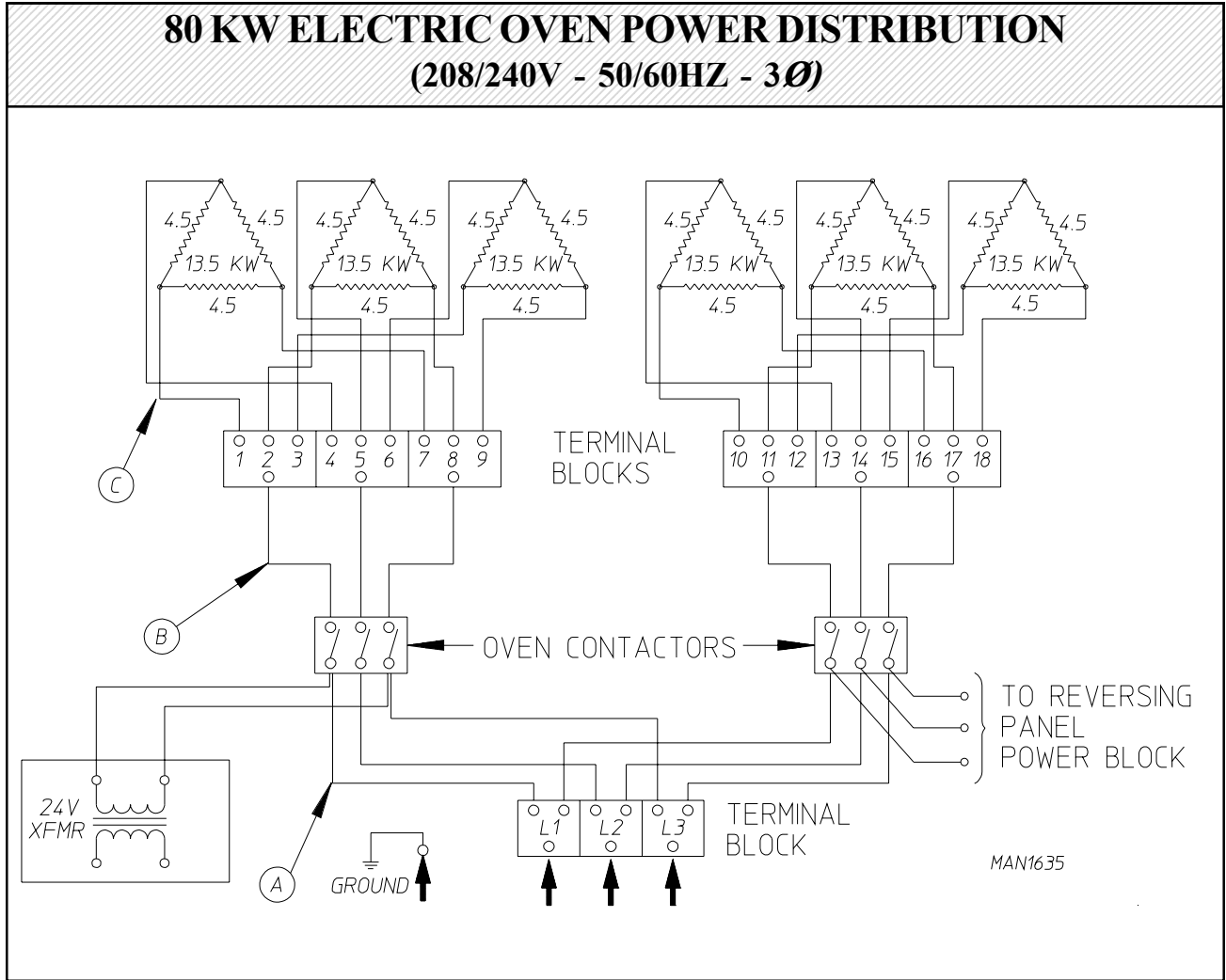

Electric Service	Qty Elements	Element Part Number	Oven Amps	Wire Service			Contactor	24 VAC Step Down Transformer
				A	B	C		
208v 3Ø 3, 4w	18	120047	222	2	2	8	131385	132004
240v 3Ø 3, 4w	18	120048	193	2	2	8	131385	132004

for 80 Kw 380/416/480 VAC models mfd. prior to April 11, 1995

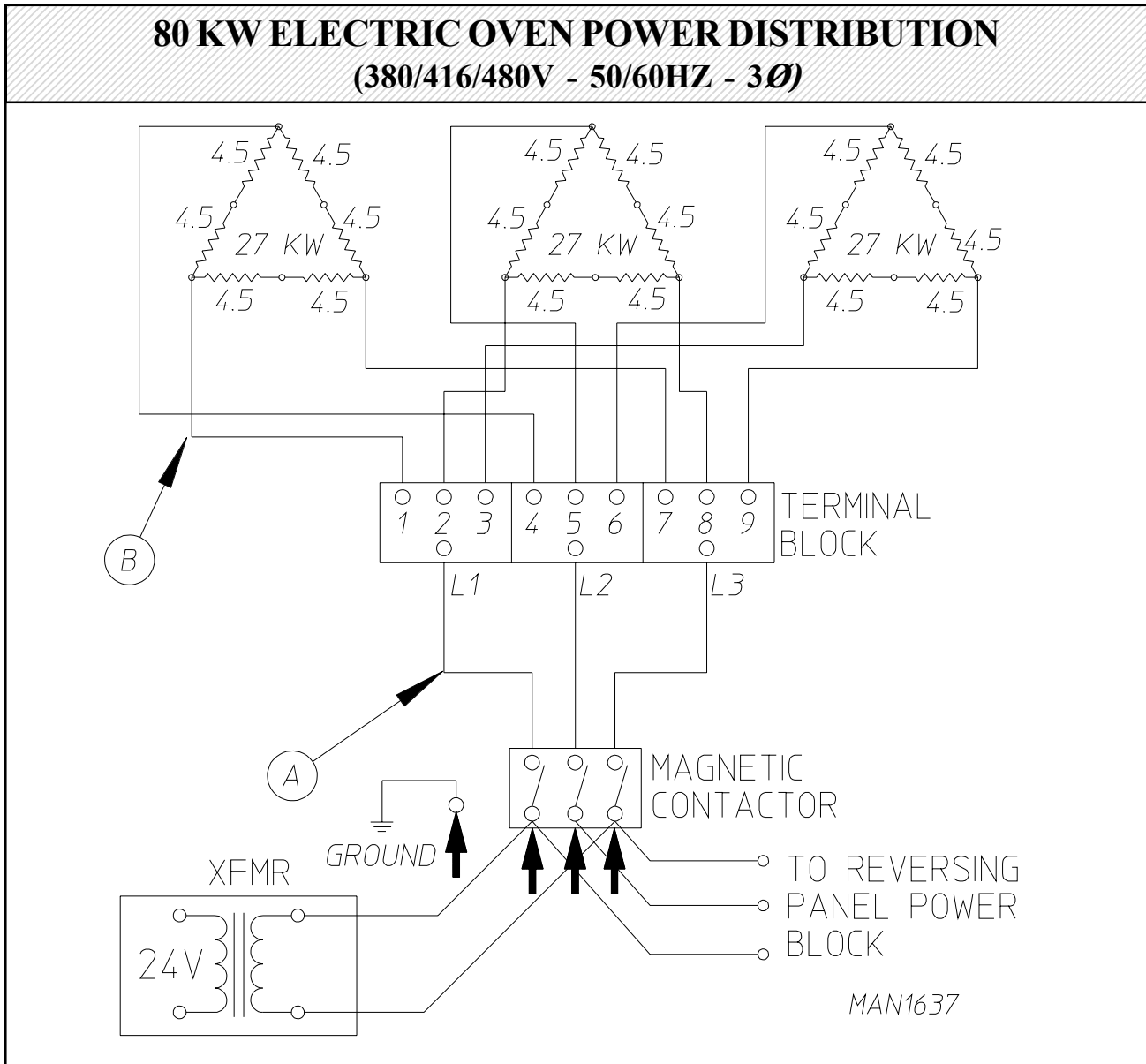

Electric Service	Qty Elements	Element Part Number	Oven Amps	Wire Service		Contactor	24 VAC Step Down Transformer
				A	B		
380v 3Ø 3, 4w	18	120022	122	1	8	131385	132004
416v 3Ø 3, 4w	18	120047	111	1	8	131385	132004
480v 3Ø 3, 4w	18	120048	96.3	2	8	131385	132004

for ALL 208/240 VAC models mfd. as of April 11, 1995

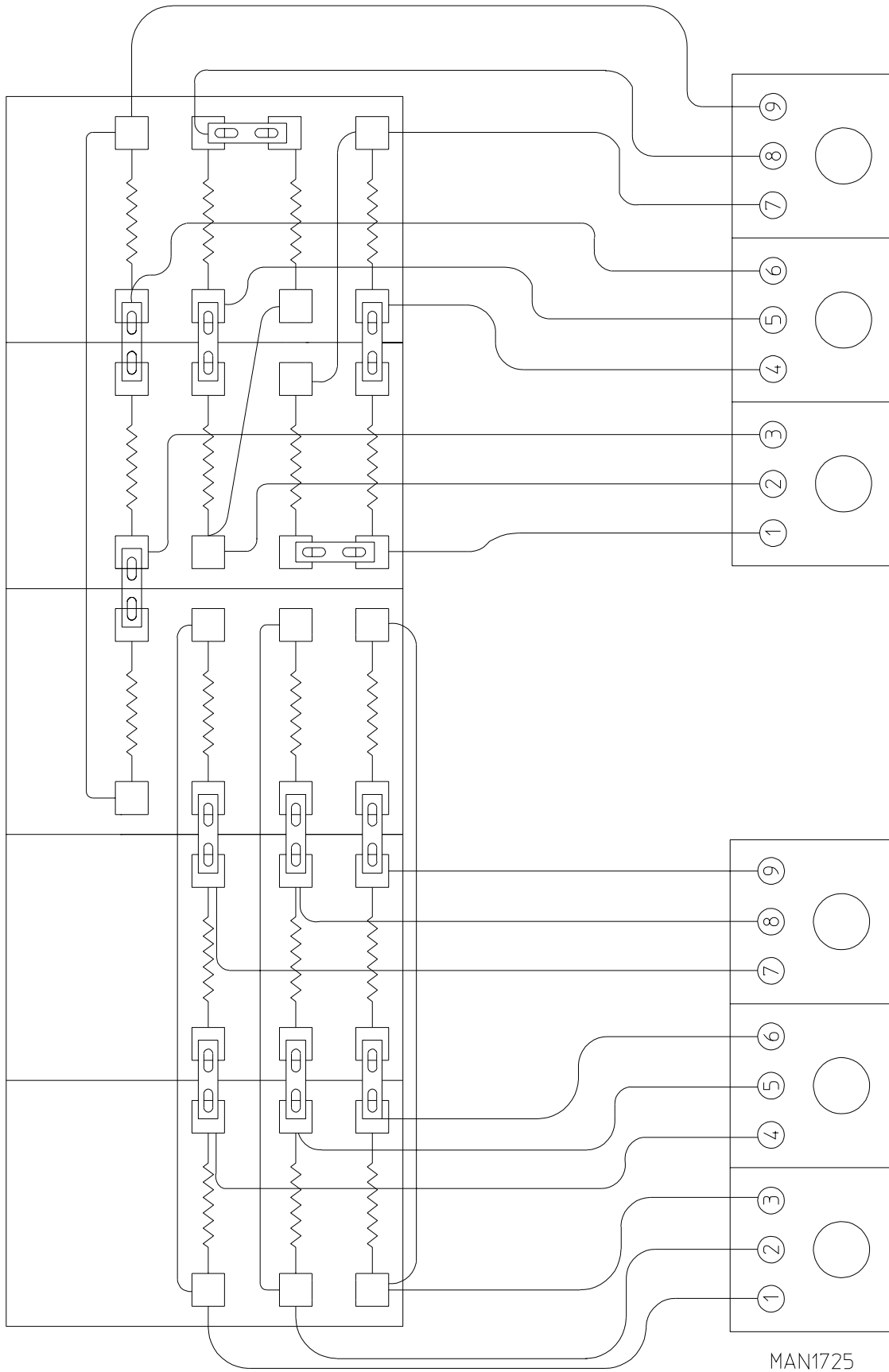

for ALL 380/416/480 VAC models mfd. as of April 11, 1995

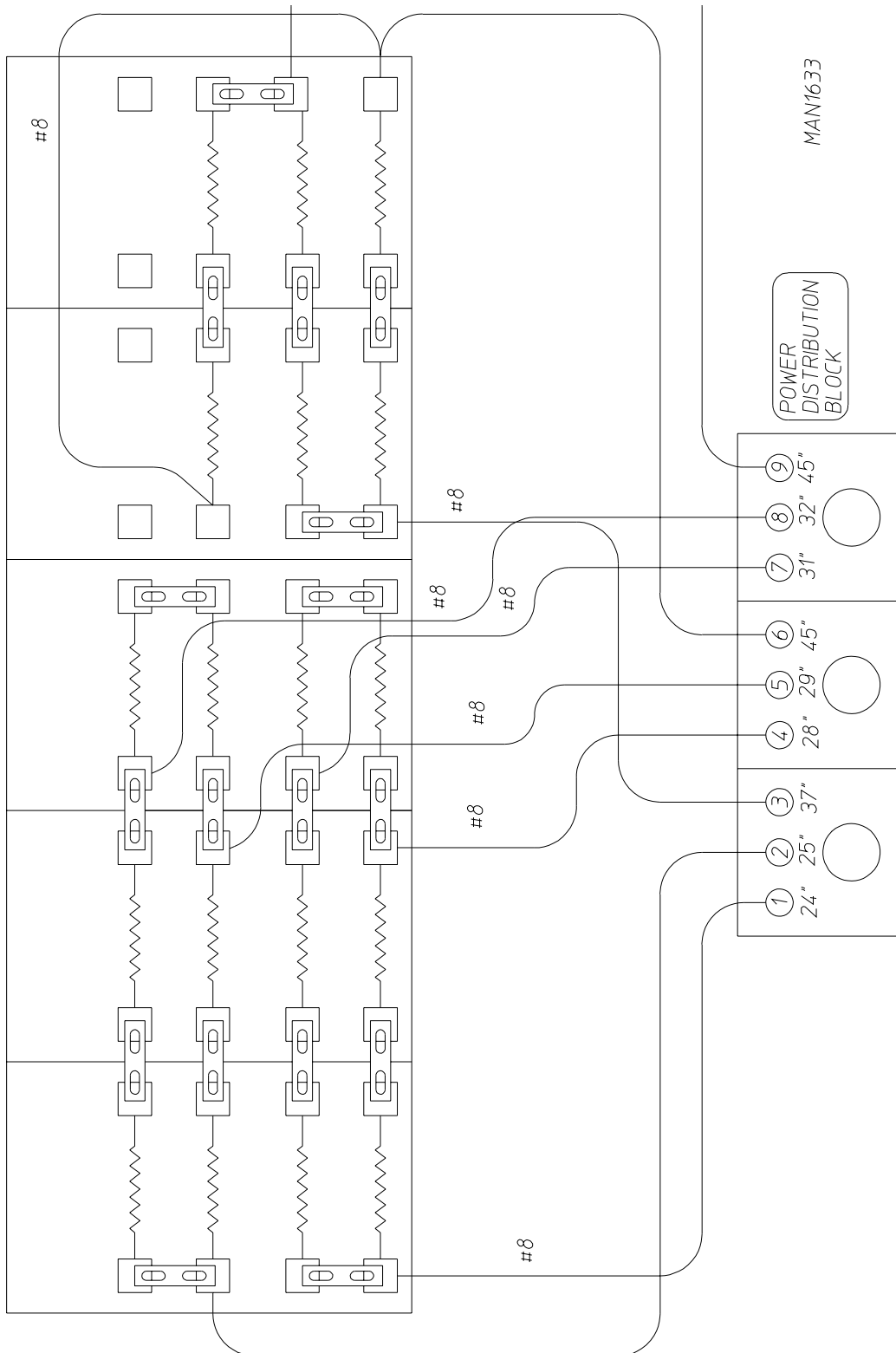

for 60 Kw 208/240 VAC models mfd. prior to April 11, 1995

ELECTRIC OVEN ELEMENT STRUCTURE (208/240V - 50/60HZ - 3Ø)

IMPORTANT: 220 - 240V OVENS USE 240V ELEMENTS

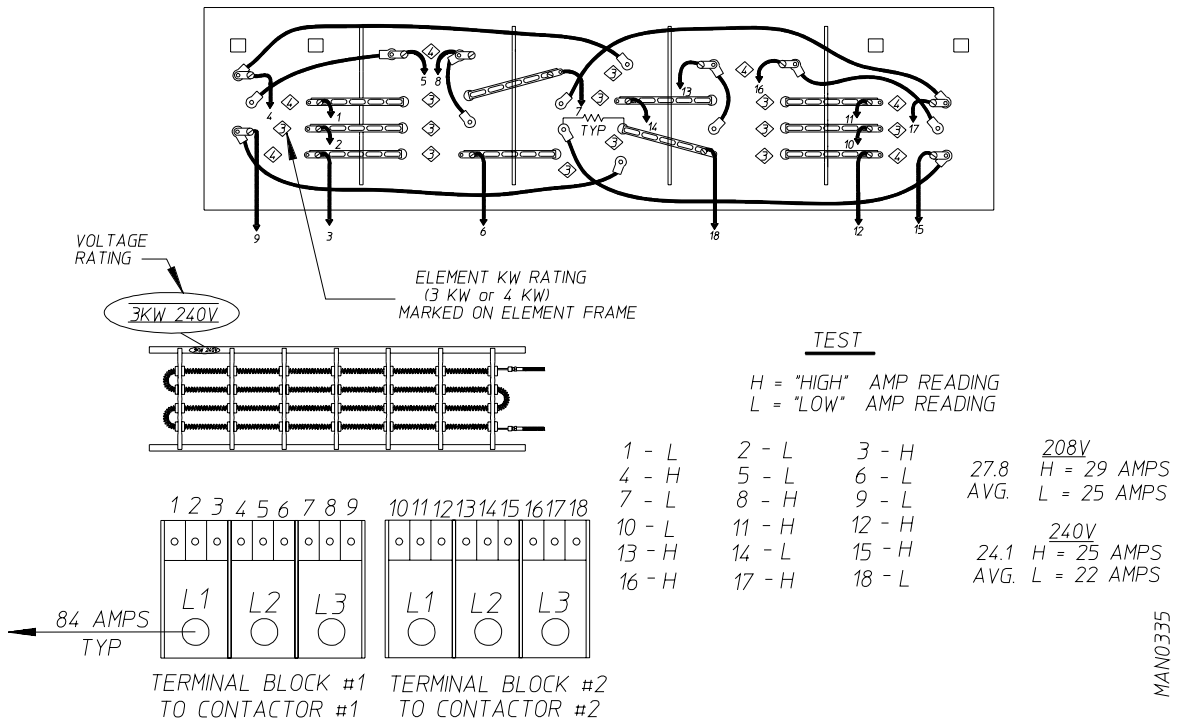

ELEMENT ARRANGEMENT, INTERCONNECTIONS, and LINE LEAD IDENTIFICATION

for 60 Kw 80/416/480 VAC models mfd. prior to April 11, 1995

ELECTRIC OVEN ELEMENT STRUCTURE (380/416/480V - 50/60HZ - 3Ø)

IMPORTANT: 416V OVENS USE 208V ELEMENTS
440-480V OVENS USE 240V ELEMENTS

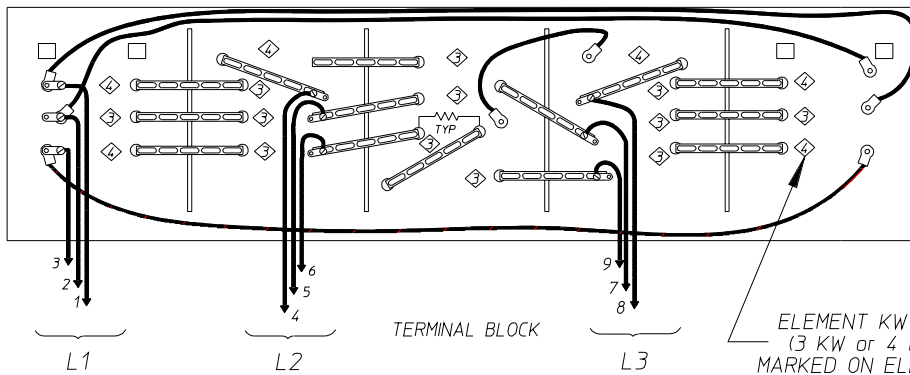

VOLTAGE RATING

4KW 208V

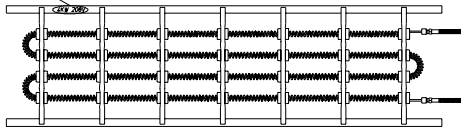

TEST

H = "HIGH" AMP READING		416V
L = "LOW" AMP READING		27.8 H = 29 AMPS
		AVG. L = 25 AMPS
1 - L 2 - L 3 - H		480V
4 - H 5 - L 6 - L		24.1 H = 25 AMPS
7 - L 8 - H 9 - L		AVG. L = 22 AMPS

MAN0336

ELEMENT ARRANGEMENT, INTERCONNECTIONS, and LINE LEAD IDENTIFICATION

Part No.	Description
112280	“Clean Lint Screen” Label
112534	“Phase 5 OPL Program Location Summary” Label
114006	“WARNING - Fire Hazards” Label
114041	“CAUTION - Exhaust/Lint Screen” Label
120100	3/8” Straight (BX) Connector
120300	3/8” x 45° (BX) Connector
120400	3/8” Red Jacket (BX) Insulator
120500	3/8” Jiffy Clip (BX Retainer Clip)
120600	3/8” Greenfield (BX)
120800	1/4” In-line Connector
120802	Red Butt Connector
120902	#74B Wire Nut
120903	Crimp-on Wire Nut
121014	1/4” Insulated (female) Terminal
121499	4” Harness Tie
121500	7” Harness Tie
121503	Harness Tie Mounting Clip
122804	Manometer (water column test gauge)
404502	White Brush-in-Cap Bottle Touch-Up Paint (0.6 oz bottle)
404506	Beige Brush-in-Cap Bottle Touch-Up Paint (0.6 oz bottle)
401010	#847 Adhesive For Felt Collar
880200	Electrical Terminal (assortment) Kit

ADC450145 **1-** 07/15/94-50 **2*** 11/04/94-100 **3*** 07/21/95-100
4* 02/08/96-100 **5*** 01/30/98-50 **6-** 08/12/99-10
7- 08/17/99-15

