



AD-235 PARTS MANUAL
24 VAC PHASE 5
1992 THRU 1998

American Dryer Corporation
88 Currant Road
Fall River, MA 02720-4781
Telephone: (508) 678-9010 / Fax: (508) 678-9447
E-mail: techsupport@amdry.com

Retain This Manual In A Safe Place For Future Reference

American Dryer Corporation products embody advanced concepts in engineering, design, and safety. If this product is properly maintained, it will provide many years of safe, efficient, and trouble-free operation.

ONLY properly licensed technicians should service this equipment.

OBSERVE ALL SAFETY PRECAUTIONS displayed on the equipment or specified in the installation/operator's manual included with the dryer.

WARNING: UNDER NO CIRCUMSTANCES should the door switch or the heat circuit devices ever be disabled.

WARNING: The dryer must never be operated with any of the back guards, outer tops, or service panels removed. PERSONAL INJURY or FIRE COULD RESULT.

We have tried to make this manual as complete as possible and hope you will find it useful. ADC reserves the right to make changes from time to time, without notice or obligation, in prices, specifications, colors, and material, and to change or discontinue models.

Important

For your convenience, log the following information:

DATE OF PURCHASE _____ **MODEL NO.** AD-235

DISTRIBUTORS NAME _____

Serial Number(s) _____

Replacement parts can be obtained from your distributor or the **ADC** factory. When ordering replacement parts from the factory, you can FAX your order to **ADC** at (508) 678-9447 or telephone your orders directly to the **ADC** Parts Department at (508) 678-9010. Please specify the dryer **model number** and **serial number** in addition to the **description** and **part number**, so that your order is processed accurately and promptly.

The illustrations on the following pages may not depict your particular dryer exactly. The illustrations are a composite of the various dryer models. Be sure to check the descriptions of the parts thoroughly before ordering.

INSTRUCTIONS TO BE FOLLOWED IN THE EVENT THE USER SMELLS GAS MUST BE POSTED IN A PROMINENT LOCATION. THE INSTRUCTIONS TO BE POSTED SHALL BE OBTAINED FROM THE LOCAL GAS SUPPLIER.

Table of Contents

Control Door Assembly	2
Lower Service Door Assembly	3
Coin Microprocessor Control Panel/Box Assemblies	4, 5
OPL Microprocessor Control Panel/Box Assemblies	6, 7
Front Panel Assembly	8
Main Door Switch Assembly	9
Main Door Assembly	10
Lint Drawer Assembly	11
Basket (Tumbler)/Support Assemblies	12, 13
Idler Bearing Assembly	14, 15
Tumbler Bearing Assembly	16, 17
Totally Enclosed, Fan-Cooled Motor Mount Assembly	18, 19
Sensor Bracket Assembly	20
Sail Switch Assembly	21
Direct Spark Ignition (DSI) Gas Valve/Burner Assembly	22, 23
Gas Burner Chamber Assembly	24
Gas Piping Assembly	25
3-Phase (3 ϕ) Motor, Electrical Relay Panel Assembly	26
Exhaust Ducting Assembly	27
Back Guard Assembly	28
Microprocessor Coin Acceptor Listing	29
Additional Parts Available	30

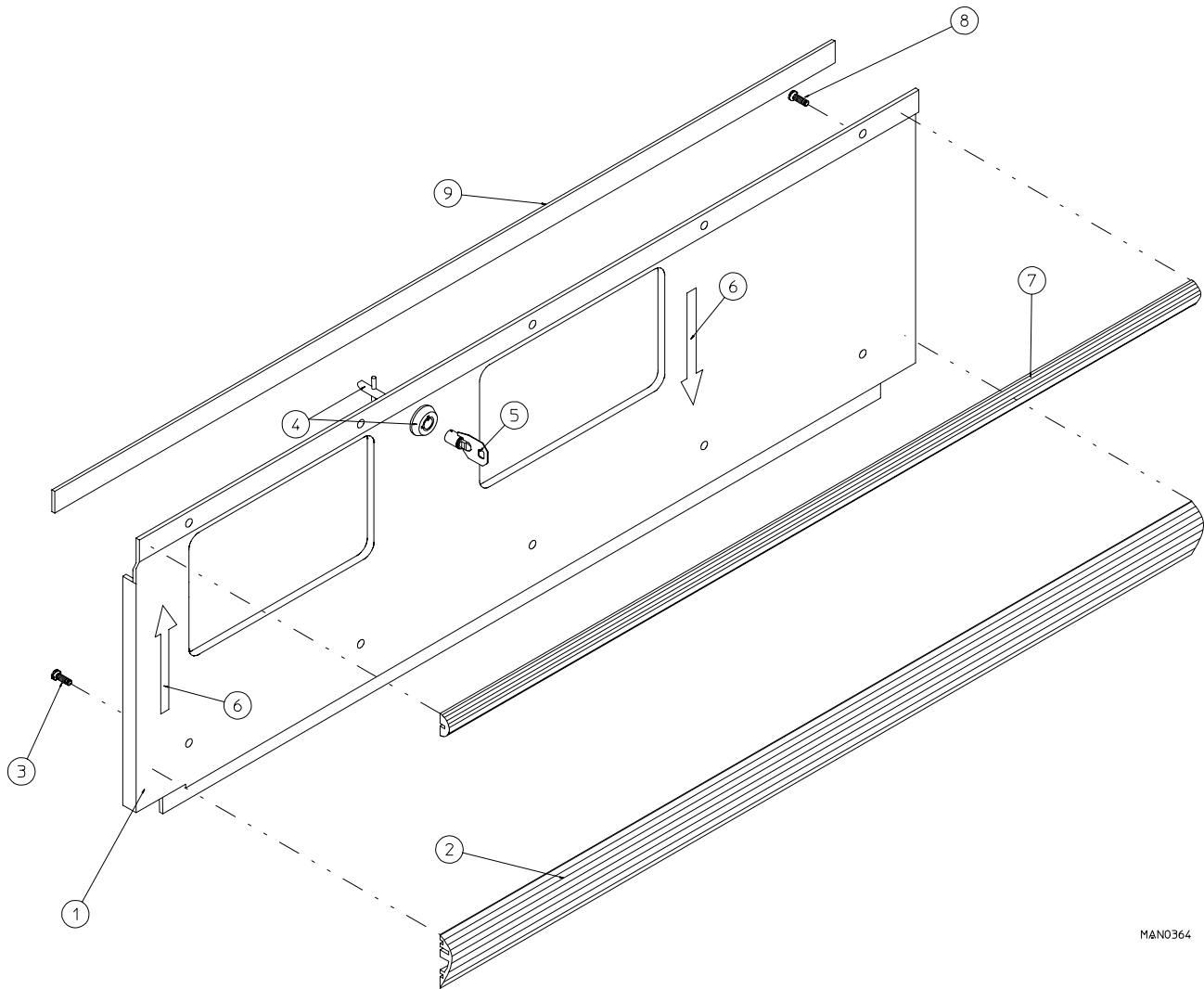

MAN0364

<u>Illus. No.</u>	<u>Part No.</u>	<u>Qty.</u>	<u>Description</u>
1*	880249	1	Control Door Assembly Complete <i>without</i> Lock (includes illus. nos. 1 through 3 and 7 through 9)
2	180313	1	Lower Black Trim Strip (28-3/8" length)
3	150201	5	#10-32 x 1/4" Phillips Round Head Machine Screw
4	160040	1	ACE® Lock Assembly <i>without</i> Key
5	160140	1	ACE® Key (key no. XX4451) ONLY
6	112077	2	"Arrow" Label
7	180305	1	Upper Black Trim Strip (28-3/8" length)
8	150201	5	#10-32 x 1/4" Phillips Round Head Machine Screw
9	117600	3	Noise Suppressor Tape (sold by the foot)

* Specify color when ordering.

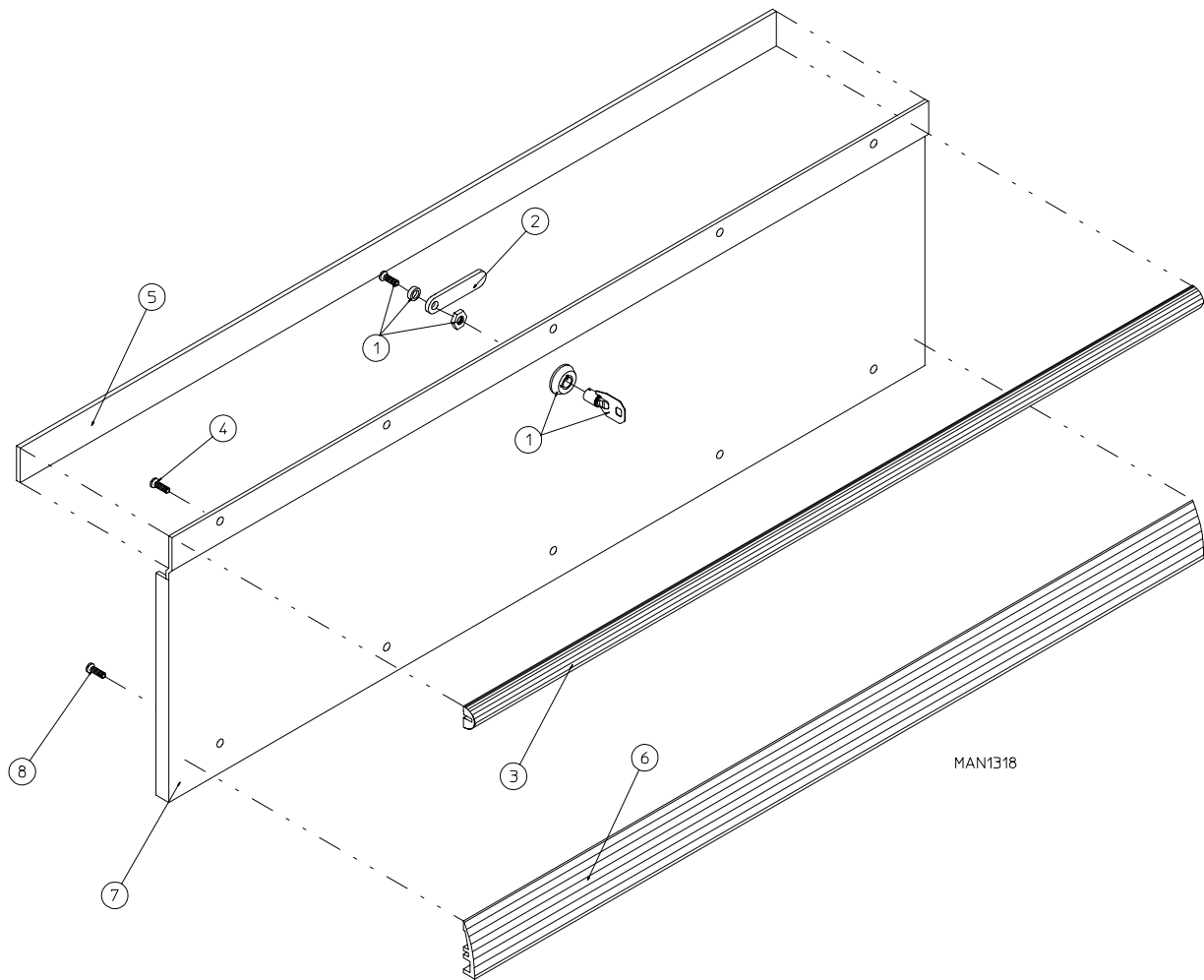

<u>Illus. No.</u>	<u>Part No.</u>	<u>Qty.</u>	<u>Description</u>
1	160038*	1	ACE® Lock Assembly <i>without</i> Key (for models mfd. as of July 20, 1992)
	160001	1	AD-100 Lock Assembly Only <i>with</i> Key (for models mfd. prior to July 3, 1992)
	160140	-	ACE® Key (key no. XX4451) ONLY (for models mfd. as of July 20, 1992)
	160103	1	AD-100 Key ONLY (for models mfd. prior to July 3, 1992)
2	160034*	1	1-3/8" Lock Cam ONLY (for models mfd. as of July 20, 1992)
	160016	1	1-1/4" Lock Cam ONLY (for models mfd. prior to July 3, 1992)
3	180305	1	Upper Black Trim Strip (28-3/8" length)
4	150201	5	#10-32 x 1/4" Phillips Round Head Machine Screw
5	117600	3	Noise Suppressor Tape (sold by the foot)
6	180313	1	Lower Black Trim Strip (28-3/8" length)
7	880260**	1	Lower Service Door Assembly Complete <i>without</i> Lock (includes illus. nos. 3 through 8)
8	150201	5	#10-32 x 1/4" Phillips Round Head Machine Screw

* Parts **must be** purchased separately.

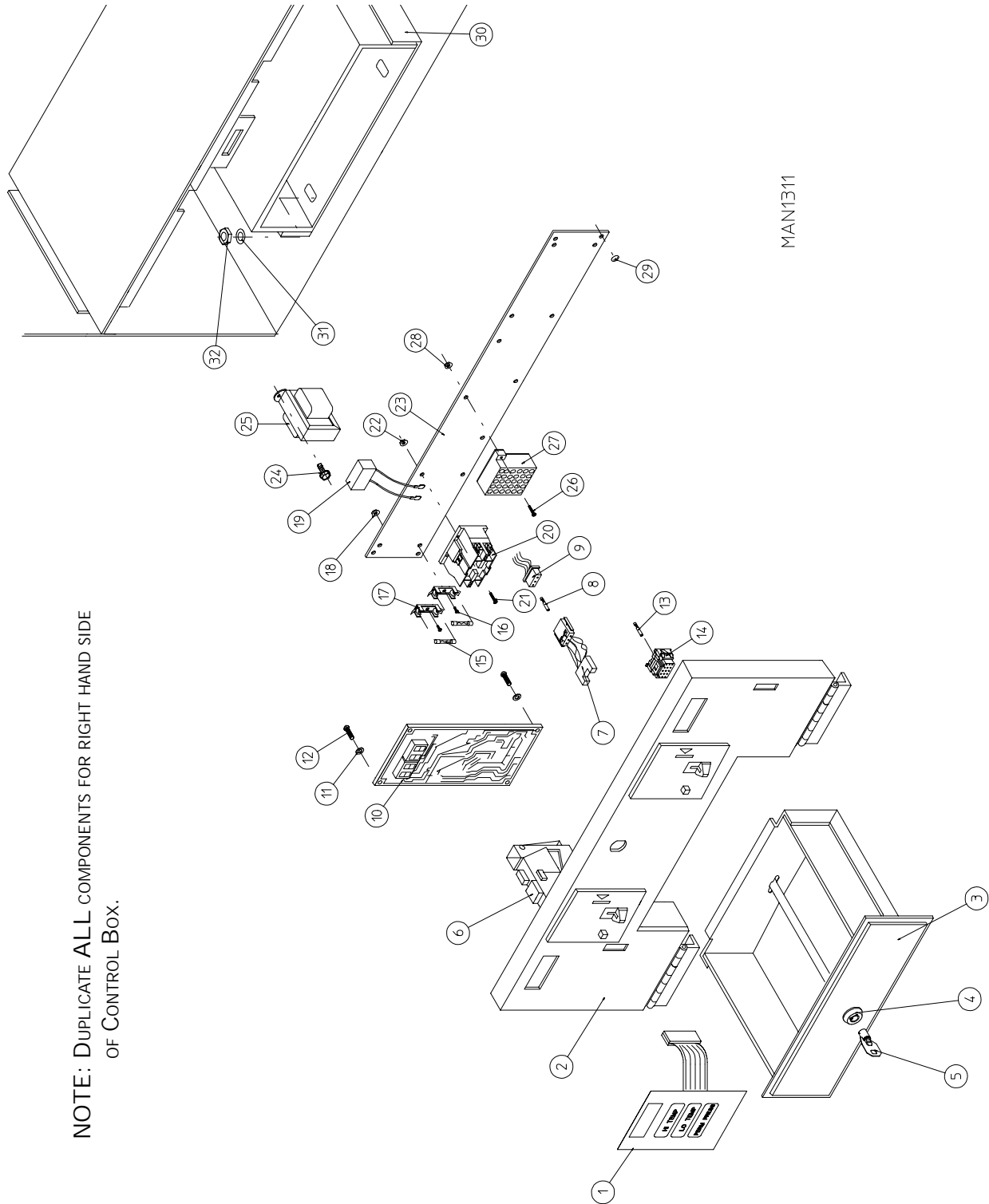

NOTE: DUPLICATE ALL COMPONENTS FOR RIGHT HAND SIDE OF CONTROL BOX.

<u>Illus. No.</u>	<u>Part No.</u>	<u>Qty.</u>	<u>Description</u>
1	112526	1	Coin Keyboard Label Assembly
2	824137	1	Phase 5 Control Panel Assembly (includes illus. nos. 1, 2, 12, 13, and 14)
	800193	1	Phase 5 Control Panel Assembly with Battery Option (includes illus. nos. 1, 2, 12, 13, and 14)
3	802142	1	Standard Coin Box Assembly Complete (includes illus. nos. 5 through 7)
	802143	1	High Security Coin Box Assembly Complete (includes illus. nos. 5 through 7)
4	160042	1	ACE® Standard Coin Box Lock Assembly Only with Key
	160043	1	ACE® High Security Coin Box Lock Assembly Only with Key
5*	160136	1	ACE® Key ONLY (for standard coin box lock)
	160135	1	ACE® Key ONLY (for high security coin box lock)
6	-----	1	Microprocessor Coin Acceptor (refer to Microprocessor Coin Acceptor Listing on page 29)
7**	137056**	1	Optical Switch ONLY
8**	137021	3	Microprocessor Socket ONLY
9	137023**	1	Optical Switch Connector
	880772	1	Single Coin Optic Switch Harness
	824080	1	Dual Coin Optic Switch Harness
10	137213	1	Phase 5 Coin Microprocessor Controller (computer) ONLY
	824998	1	Phase 5 Battery Clip
11	153010	2	#6 Star Washer
12	150005	2	#6-32 x 1/4" Phillips Round Head Machine Screw
13	122706	15	Microprocessor Socket ONLY
14	122641	1	15-Pin Microprocessor Connector ONLY
	122800	1	Microprocessor (female) Pin Extraction Tool
15	136057	1 or 2	1/2-Amp (Slo Blo) Fuse
16	150002	1 or 2	#6-32 x 1" Phillips Round Head Machine Screw
17	136008	1 or 2	3-Position Fuse Block
18	151000	1 or 2	#6-32 Pal Nut
19	824828	1	RC Network with Connectors
20	132451	1	2-Pole Contactor
21	150103	2	#8-32 x 3/4" Phillips Round Head Machine Screw
22	151001	2	#8-32 Pal Nut
23	824435	1	Control Box Panel Assembly Complete - for Gas Models ONLY (includes illus. nos. 15 through 23, and 26 through 28)
24	150300	2	#10 x 1/2" Hex Washer TEK Screw
25	141403	1	24 VAC Transformer (for 60 Hz models Only)
	132023	1	24 VAC Transformer (for 50 Hz models Only)
26	150002	2	#6-32 x 1" Phillips Round Head Machine Screw
27	120715	1	30-Position Terminal Block
28	151000	2	#6-32 Pal Nut
29	151001	6	#8-32 Pal Nut
30	802140	1	Standard Coin Vault ONLY
	802141	1	High Security Coin Vault ONLY
31***	153018	4	1/4" Flat Washer
32	152014	4	1/4-20 Free Spin Wash Nut
	152002***	4	1/4-20 Hex Nut

* Specify key number when ordering.

** For Dual Coin, double the quantity.

*** For use on High Security Coin Vault ONLY.

IMPORTANT: Check label on computer chip to verify correct part number for controller (computer).

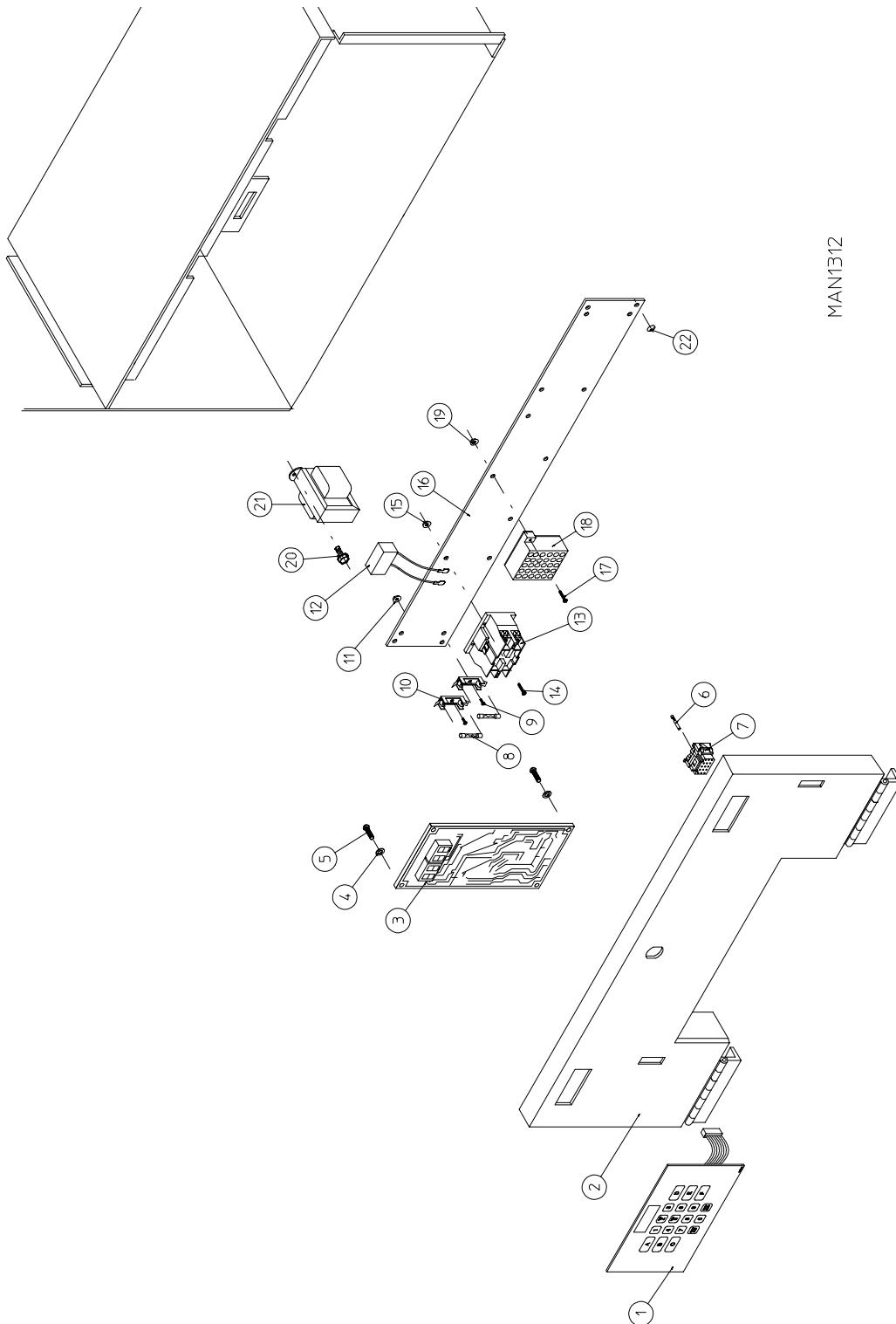

MAN1312

<u>Illus. No.</u>	<u>Part No.</u>	<u>Qty.</u>	<u>Description</u>
1	112535	1	OPL English Keyboard Label Assembly
	112276	1	OPL Stick-on Labels (English Only) ... Not Illustrated
	112275	1	OPL Stick-on Labels (Spanish, Italian, and Hebrew) ... Not Illustrated
	112277	1	3 Language OPL Stick-on Labels (English, Spanish, and Hebrew) ... Not Illustrated
	112278	1	5 Language OPL Stick-on Labels (Italian, Dutch, French, German, and Chinese) ... Not Illustrated
2	880844	1	Phase 5 OPL Microprocessor Control Panel Assembly (includes illus. nos. 1 through 5)
3	137222	1	Phase 5 OPL Microprocessor Controller (computer) ONLY
	824998	1	Phase 5 Battery Clip
4	153010	2	#6 Star Washer
5	150005	2	#6-32 x 1/4" Phillips Round Head Machine Screw
6	122706	15	Microprocessor Socket ONLY
7	122641	1	15-Pin Microprocessor Connector ONLY
	122800	1	Microprocessor (female) Pin Extraction Tool
8	136057	1 or 2	1/2-Amp (Slo Blo) Fuse
9	150002	1 or 2	#6-32 x 1" Phillips Round Head Machine Screw
10	136008	1 or 2	3-Position Fuse Block
11	151000	1 or 2	#6-32 Pal Nut
12	824828	1	RC Network with Connectors
13	132451	1	2-Pole Contactor
14	150103	2	#8-32 x 3/4" Phillips Round Head Machine Screw
15	151001	6	#8-32 Pal Nut
16	824435	1	Control Box Panel Assembly Complete (includes illus. nos. 15 through 23, and 26 through 28) For Gas Models ONLY
17	150002	2	#6-32 x 1" Phillips Round Head Machine Screw
18	120715	1	30-Position Terminal Block
19	151000	2	#6-32 Pal Nut
20	150300	2	#10 X 1/2" Hex Washer TEK Screw
21	141403	1	24 VAC Transformer (for 60 Hz models Only)
	132023	1	24 VAC Transformer (for 50 Hz models Only)
22	151001	6	#8-32 Pal Nut

IMPORTANT: Check label on computer chip to verify correct part number for controller (computer).

UPPER FRONT PANEL ASSEMBLY

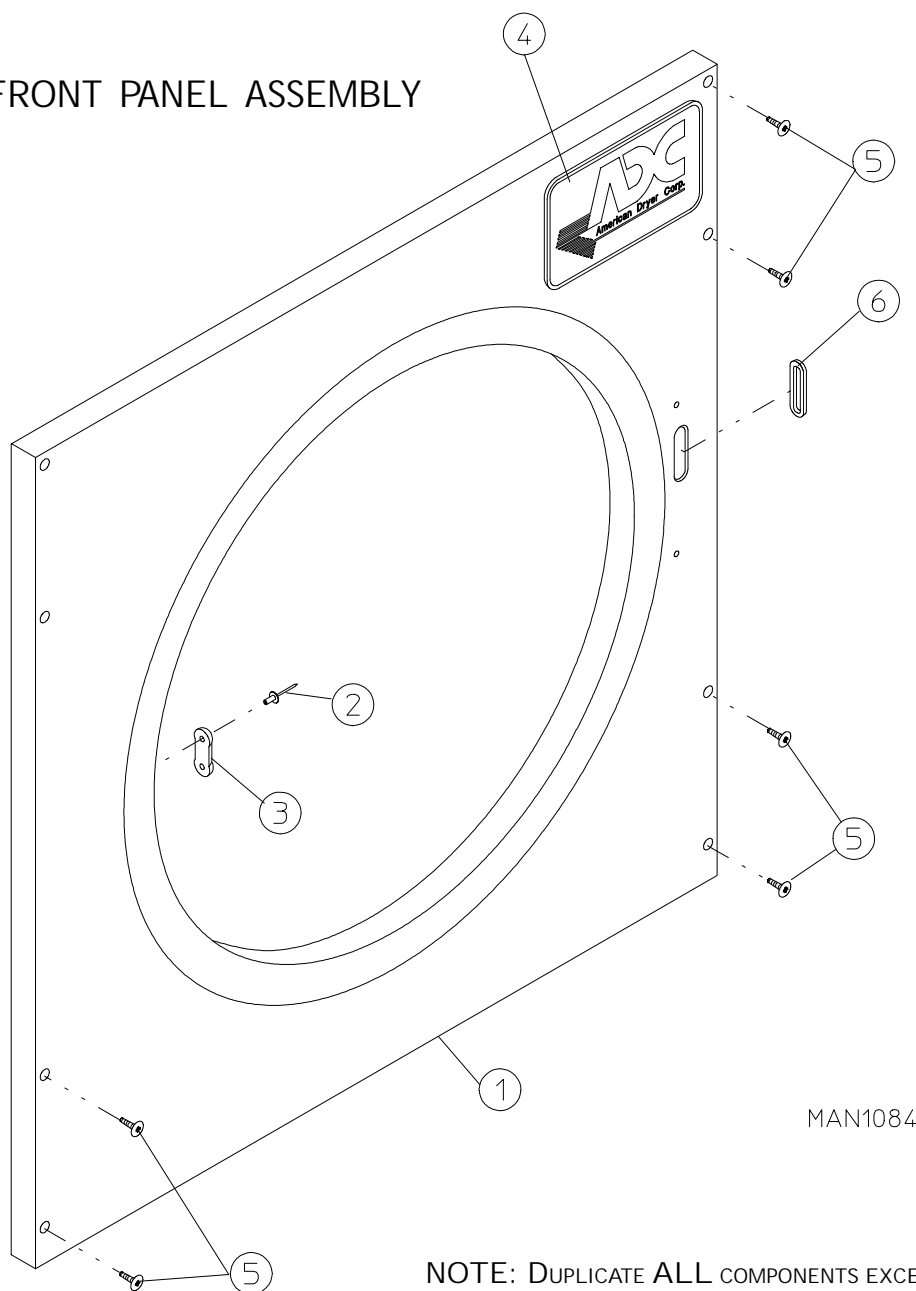

MAN1084

NOTE: DUPLICATE ALL COMPONENTS EXCEPT LOGO FOR LOWER FRONT PANEL ASSEMBLY.

Illus. No.	Part No.	Qty.	Description
1	800692*	1	Right Hand Insulated Front Panel Assembly (includes illus. nos. 1, 2, 3, and 6)
2	154215	2	1/8" Pop Rivet
3	170330	1	Friction Door Latch
4	112350	1	ADC Logo ONLY
	870011	1	Logo Double Tape Kit
5	150309	8	#10-16 x 1/2" Hex Head TEK Crimptite Screw
6	121405	1	Rubber Grommet

* Specify color when ordering.

UPPER MAIN DOOR SWITCH ASSEMBLY

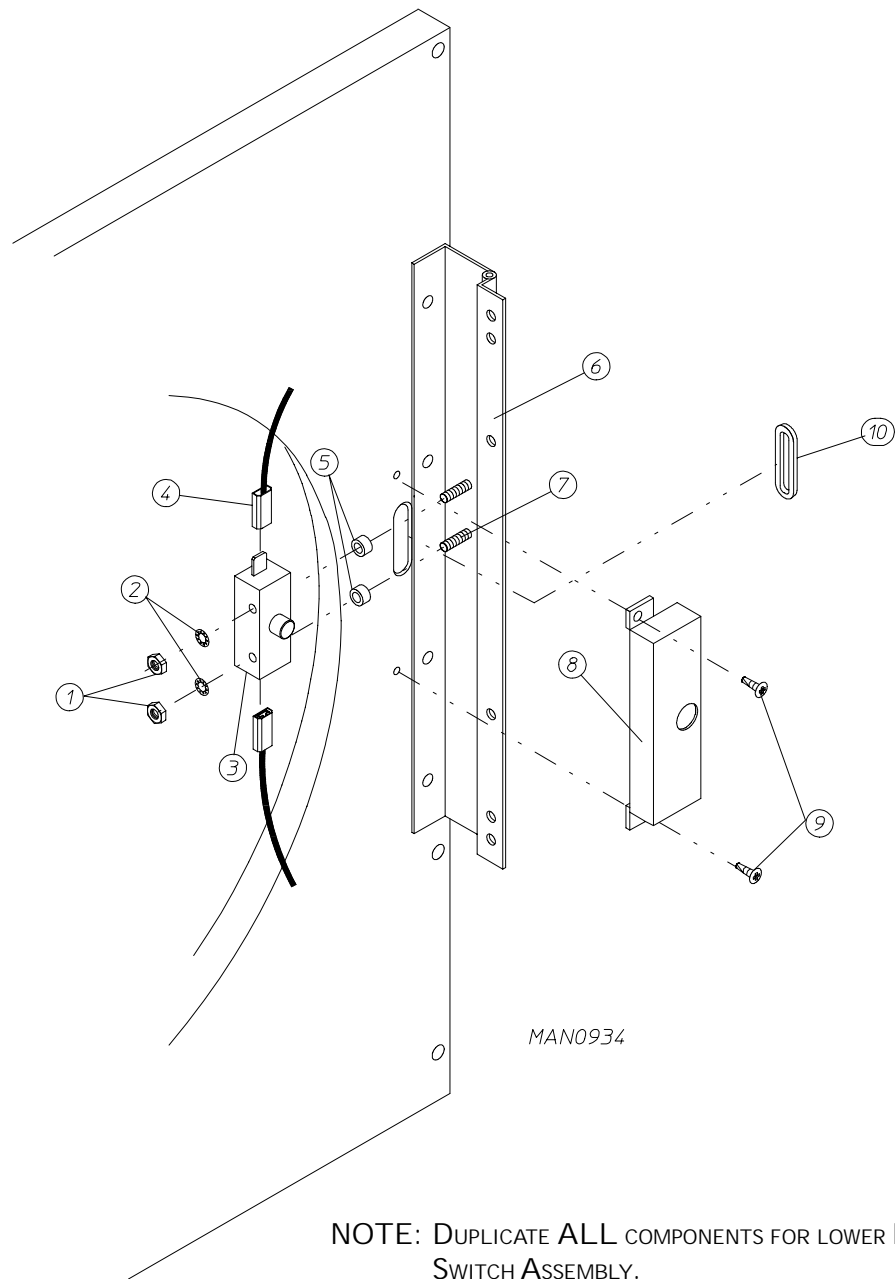

<u>Illus. No.</u>	<u>Part No.</u>	<u>Qty.</u>	<u>Description</u>
1	152012	2	#6-32 Hex Nut
2	153008	2	#6 Lock Washer
3	137005	1	Single Pole Door Switch
4	121028	2	Insulated Female Terminal
5	154281	2	3/8" Nylon Spacer
6	800448	1	12-1/2" Stainless Steel Main Door Hinge (includes illus. nos. 6 and 7)
7	153565	2	#6 Stud
8	881246	1	Main Door Switch Housing ONLY
9	150201	2	#10-32 x 1/4" Phillips Pan Head Screw
10	121405	1	Rubber Grommet

UPPER MAIN DOOR ASSEMBLY

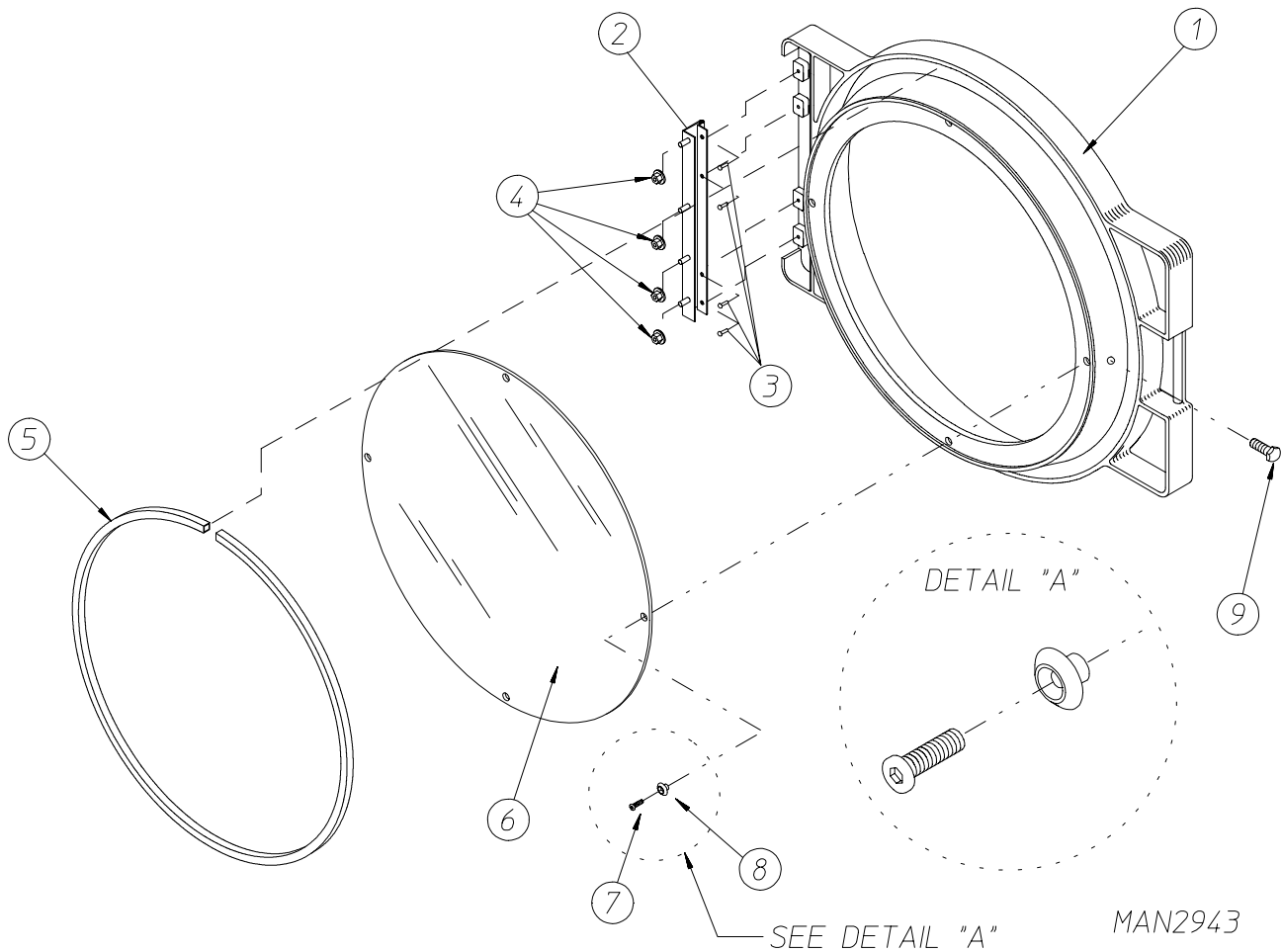

NOTE: DUPLICATE ALL COMPONENTS FOR LOWER MAIN DOOR ASSEMBLY.

<u>Illus. No.</u>	<u>Part No.</u>	<u>Qty.</u>	<u>Description</u>
1	881422	1	Black Plastic Main Door Assembly Complete with Mechanical Fasteners (includes illus. nos. 1 and 5 through 9)
2	800448	4	12-1/2" Stainless Steel Main Door Hinge Assembly
3	150410	4	#10-24 x 3/8" Phillips Pan Head Taptite Screw
4	152014	1	1/4-20 Free Spin Wash Nut
5	102349	1	Main Door Gasket
6	102212	1	20-7/16" Door Glass with (4) Holes
	170730	1	Main Door Glass Adhesive (10.3 oz. cartridge)
7	150448	4	1/2" Stainless Steel Flat Head Allen Screw
8	170319	4	Door Glass (Nylon) Spacer
9	150431	1	Main Door Latch Screw (#10 x 7/16" Dome Hex Head)

UPPER LINT DRAWER ASSEMBLY

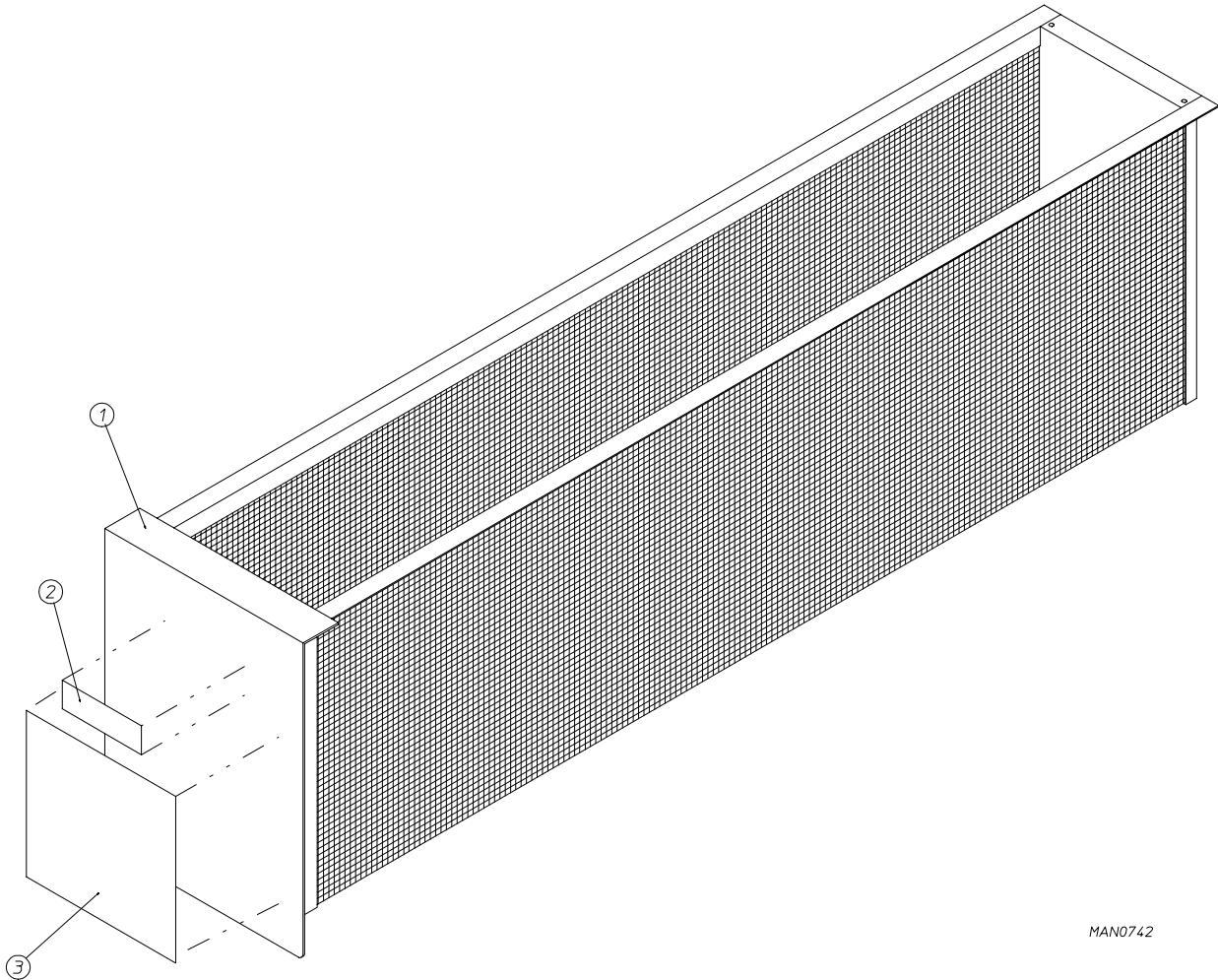

MAN0742

NOTE: DUPLICATE ALL COMPONENTS EXCEPT PROGRAM LOCATION LABEL FOR LOWER LINT DRAWER ASSEMBLY.

<u>Illus. No.</u>	<u>Part No.</u>	<u>Qty.</u>	<u>Description</u>
1	850667	1	Lint Drawer Assembly
2	112040	1	Lint Label
3	112533	1	“Phase 5 Coin Program Location” Label (for use on Coin Models Only)
	112534	1	“Phase 5 OPL Program Location” Label (for use on Non-Coin Models Only)

UPPER BASKET (TUMBLER)/SUPPORT ASSEMBLY

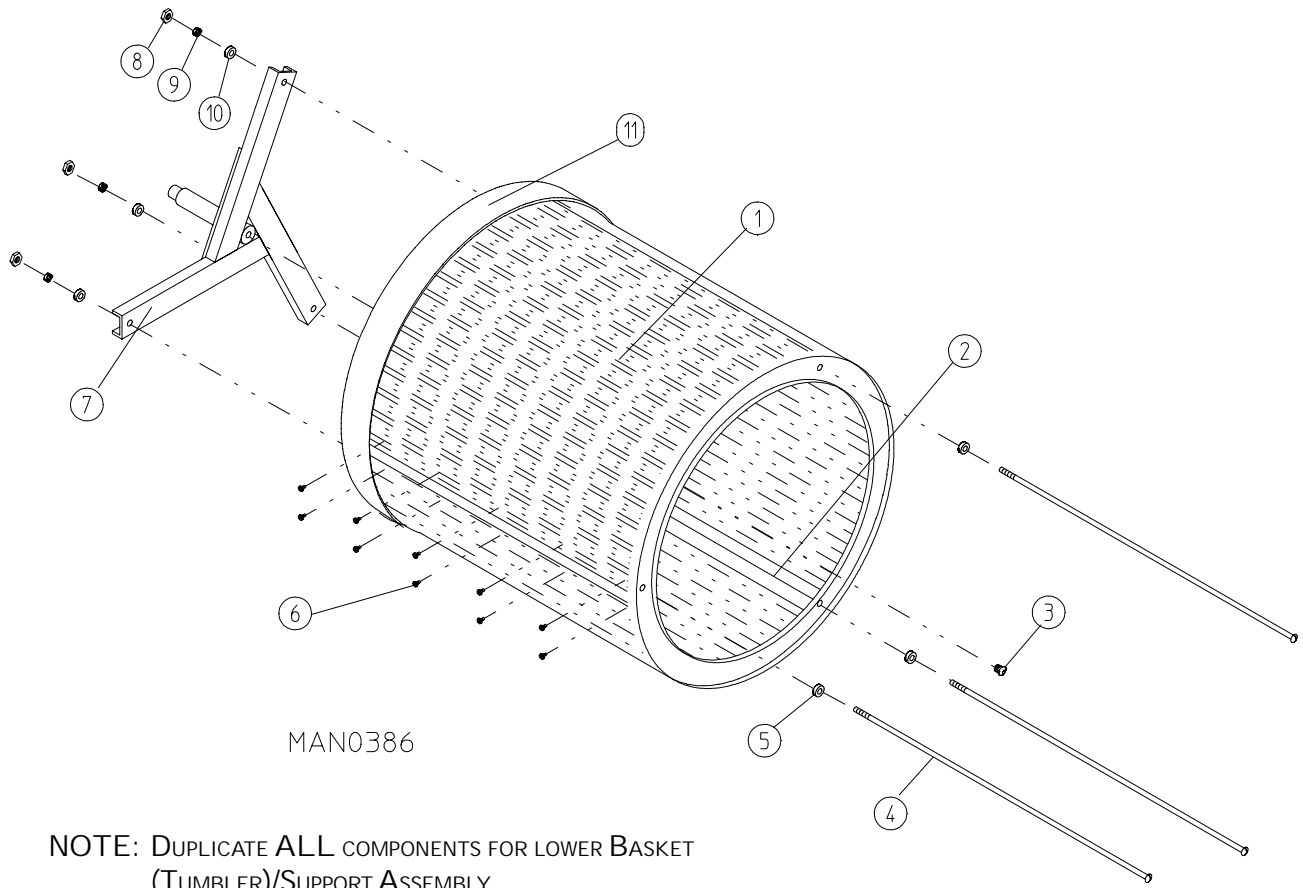

MAN0386

NOTE: DUPLICATE ALL COMPONENTS FOR LOWER BASKET (TUMBLER)/SUPPORT ASSEMBLY.

<u>Illus. No.</u>	<u>Part No.</u>	<u>Qty.</u>	<u>Description</u>
1	800831	1	Basket (Tumbler) and Support Assembly Complete <i>with</i> Felt Collar (includes illus. nos. 1 through 11)
	800721*	1	Basket (Tumbler) ONLY (includes illus. nos. 1, 2, and 6)
	800891	1	Stainless Steel Basket (Tumbler) and Support Assembly Complete <i>with</i> Felt Collar (includes illus. nos. 1 through 11)
	800841*	1	Stainless Steel Basket (Tumbler) ONLY (includes illus. nos. 1, 2, and 6)
2	301315	2	Short Basket (Tumbler) Rib ONLY
	301316	1	Tall Basket (Tumbler) Rib ONLY
	301414	2	Stainless Steel Short Basket (Tumbler) Rib ONLY
	301415	1	Stainless Steel Tall Basket (Tumbler) Rib ONLY
3	150518	1	5/16-18 x 3/8" Socket Button Head Screw
4	100902	3	5/16-18 x 31" Tie Rod
5	153001	3	5/16" Flat Washer
6	154210	30	5/32" x 3/16" Pop Rivet
7	800617	1	Basket (Tumbler) Support ONLY
8	152004	3	5/16-18 Hex Nut
9	153002	3	5/16" Lock Washer
10	153001	3	5/16" Flat Washer
11	116003	1	Felt Collar ONLY
	401010	1	#847 Adhesive for Felt Collar (5 oz. tube)

* Felt collar *is not included* and **must be** ordered separately.

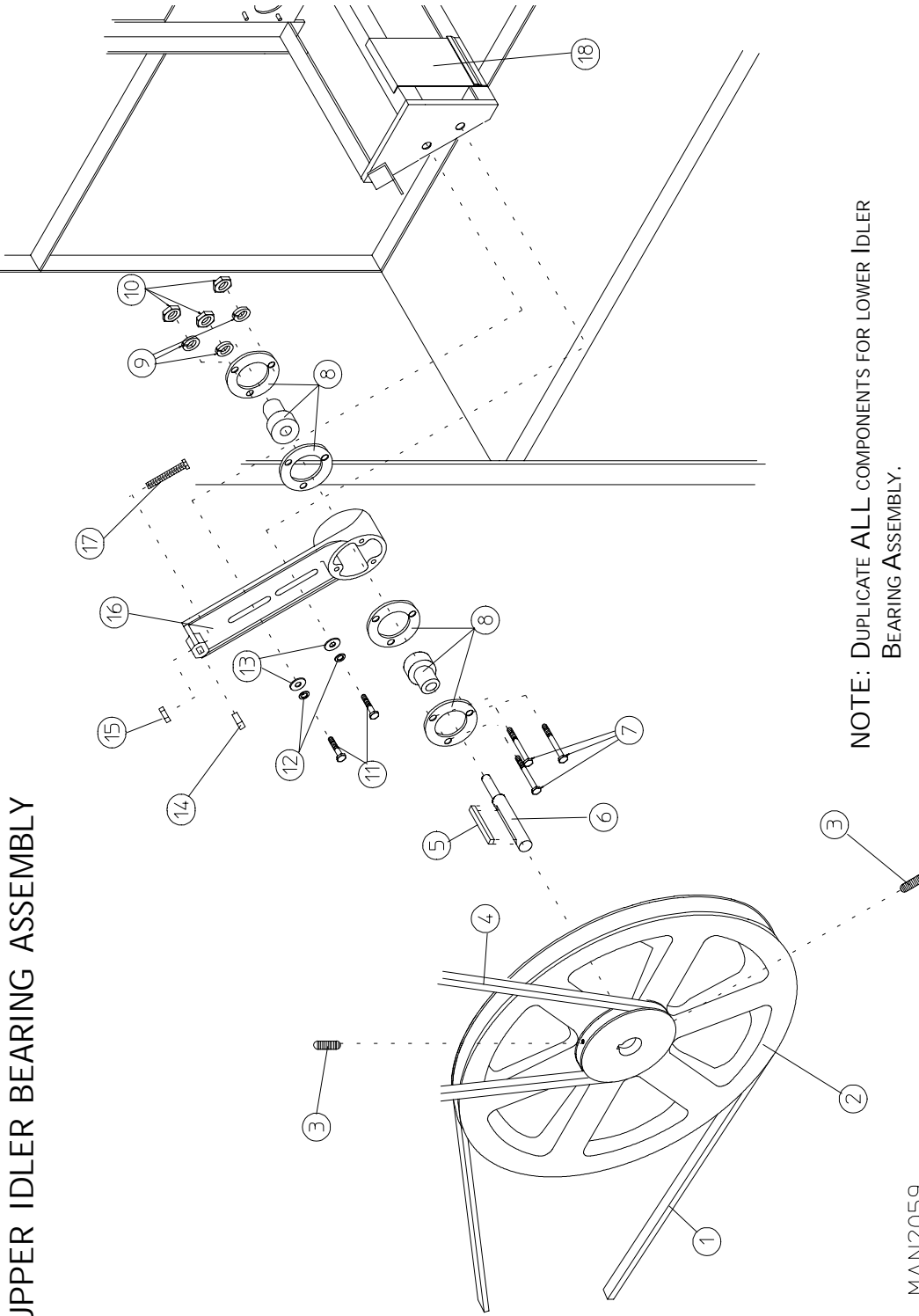

<u>Illus. No.</u>	<u>Part No.</u>	<u>Qty.</u>	<u>Description</u>
1	100113	1	4L-400 V- Belt (idler to motor) For 60 Hz models ONLY
	100115	1	4L-410 V-Belt (idler to motor) For 50 Hz models ONLY
2	101129	1	9" x 2-1/2" Pulley with 3/16" Key
3	154301	2	5/16-18 x 5/16" Allen Set Screw
4	100100	1	5L-660 V-Belt (idler to basket/tumbler)
5	100705	1	3/16" x 3/16" x 1-3/8" Key
6	301850	1	5/8" x 3/4" Idler Shaft
7	150529	3	1/4-20 x 2-1/4" Carriage Bolt
8	100214	2	5/8" Flange Bearing
9	153007	3	1/4" Lock Washer
10	152002	3	1/4-20 Hex Nut
11	150617	2	3/8-16 x 1" Hex Head Machine Bolt
12	153005	2	3/8" Lock Washer
13	153004	2	3/8" Flat Washer
14	152020	1	5/16-18 Standard Square Nut
15	152004	1	5/16-18 Hex Nut
16	801010	1	Idler Bearing Assembly Complete (includes illus. nos. 6 through 17)
	100406	1	Idler Bearing Mount ONLY
17	150509	1	5/16-18 x 3" Hex Head Machine Bolt
18	-----	-	DSI Module Mounting Bracket (refer to DSI Gas Valve/Burner Assembly on page 22 and page 23)

UPPER TUMBLER BEARING ASSEMBLY

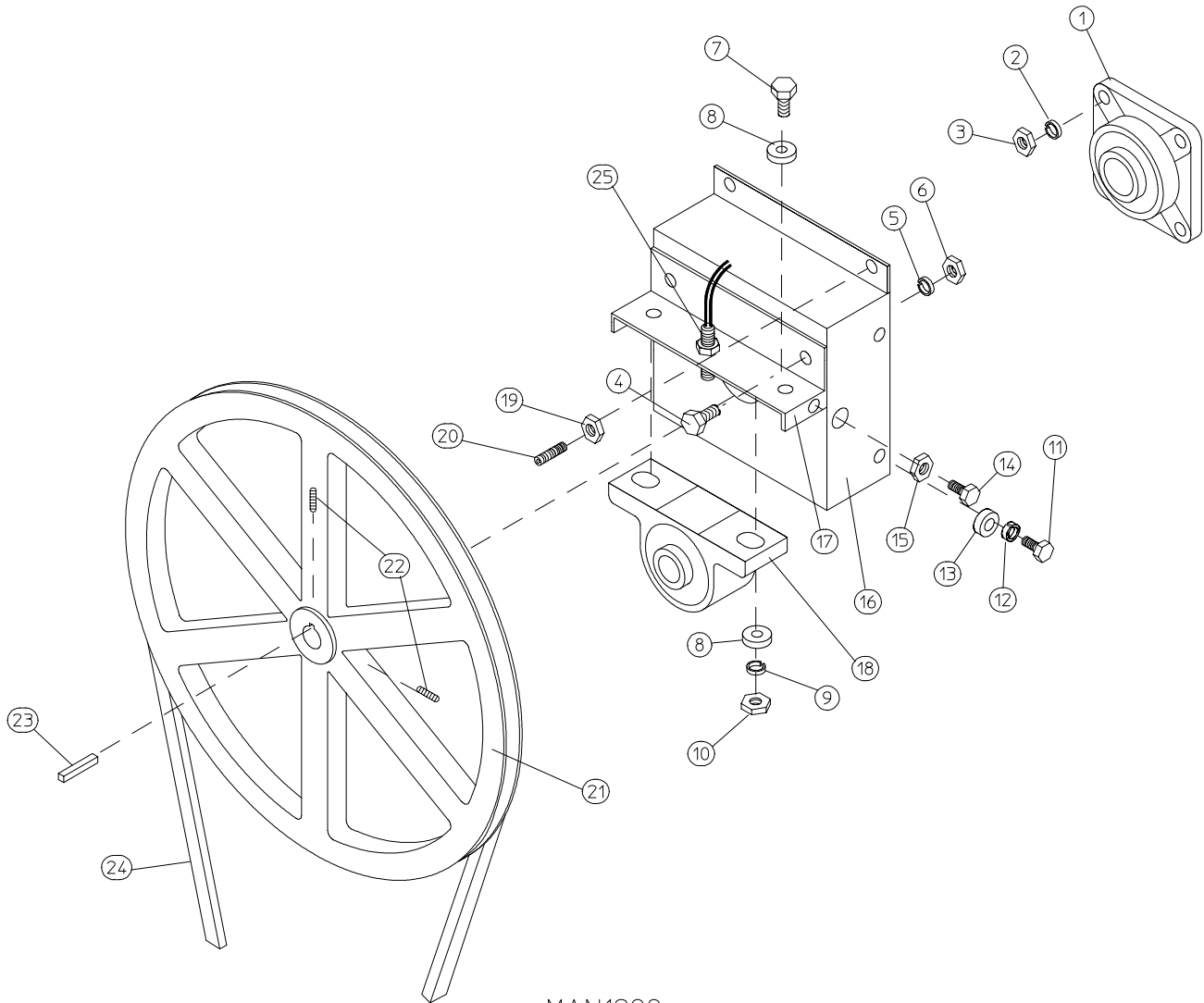

MAN1299

NOTE: DUPLICATE ALL COMPONENTS FOR LOWER TUMBLER BEARING ASSEMBLY.

<u>Illus. No.</u>	<u>Part No.</u>	<u>Qty.</u>	<u>Description</u>
1	880203	1	1-3/8" Flange Bearing <i>with</i> Nylock Set Screw
2	153005	4	3/8" Lock Washer
3	152005	4	3/8-16 Hex Nut
4	150508	2	3/8-16 x 3/4" Hex Head Machine Bolt
5	153005	2	3/8" Lock Washer
6	152005	2	3/8-16 Hex Nut
7	150600	2	3/8-16 x 1-1/2" Hex Head Machine Bolt
8	153004	2	3/8" Flat Washer
9	153005	2	3/8" Lock Washer
10	152005	2	3/8-16 Hex Nut
11	150501	4	5/16-18 x 3/4" Hex Head Machine Bolt
12	153002	4	5/16" Lock Washer
13	153001	4	5/16" Flat Washer
14	150621	2	5/16-18 x 1-1/2" Hex Head Machine Bolt
15	152004	2	5/16-18 Hex Nut
16	801101	1	1-3/8" Bearing Box Assembly Complete (includes illus. nos. 4 through 20) For models mfd. <i>without</i> rotational sensor
	801103	1	1-3/8" Bearing Box and Support ONLY (includes illus. nos. 9, 10, 13, 14, and 15)
	801105	1	1-3/8" Bearing Box ONLY
17	801104	1	Pillow Block Bearing Support ONLY
18	880779	1	1-3/8" Pillow Block Bearing Assembly <i>with</i> Magnet (for models mfd. <i>without</i> rotational sensor)
	100202	1	1-3/8" Pillow Block Bearing <i>with</i> Nylock Set Screw
19	152004	2	5/16-18 Hex Nut
20	150610	2	5/16-18 x 1-1/2" Allen Set Screw
21	101100	1	18" Cast Pulley
22	154301	2	5/16-18 x 5/16" Allen Set Screw
23	100713	1	1/4" x 1/4" x 7/8" Key
24	100100	1	5L-660 V-Belt (basket/tumbler to idler)
25	824807	1	Rotational Sensor Assembly

UPPER TUMBLER BEARING ASSEMBLY

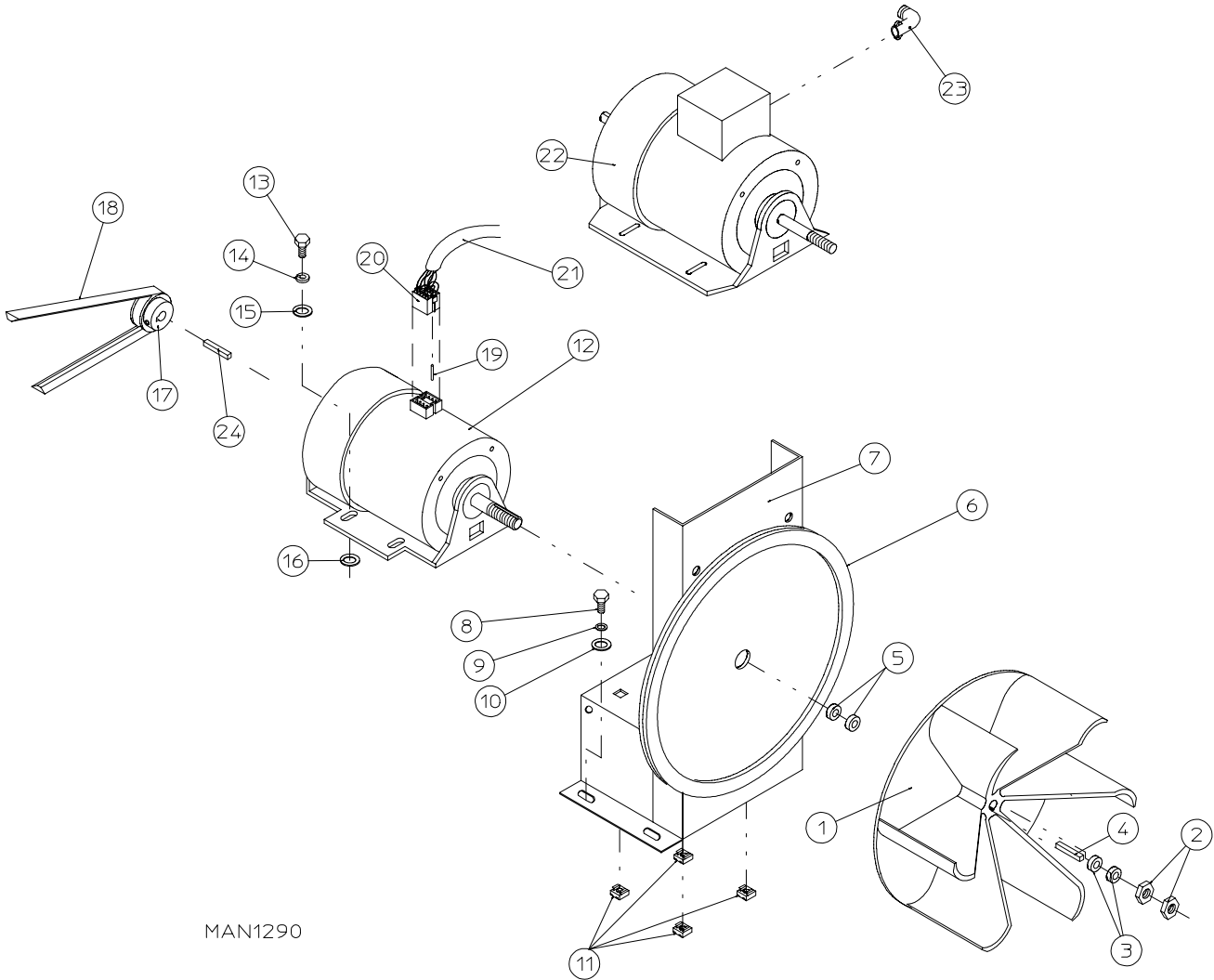

MAN1290

NOTE: DUPLICATE ALL COMPONENTS FOR LOWER TUMBLER BEARING ASSEMBLY.

<u>Illus. No.</u>	<u>Part No.</u>	<u>Qty.</u>	<u>Description</u>
1	100604	1	12-1/2" Impellor with 1/2" Bore
2	152006	2	1/2-20 Left Hand Jam Nut
3	153050	*	1/2" S.A.E. Flat Washer
4	100702	1	1/8" x 1/8" x 1-1/2" Key
5	153050	*	1/2" S.A.E. Flat Washer
6	117600	4	Noise Suppressor Tape (sold by the foot)
7	850019	1	Motor Mount ONLY
	803963**	1	1/2 HP 100/120-230v 1 ϕ 50/60 Hz T.E.F.C. Motor Mount Assembly Complete <i>with</i> Plug Motor (includes illus. nos. 1 through 7 and 11 through 17) For models mfd. as of August 28, 1992
	880848**	1	1/2 HP 208/230/380/460v 60Hz 3 ϕ T.E.F.C. Motor Mount Assembly Complete (includes illus. nos. 1 through 7, 11, 13 through 17, 22, and 23)
	803902**	1	1/2 HP 208/230/380/460v 3 ϕ 50 Hz T.E.F.C. Motor Mount Assembly Complete (includes illus. nos. 1 through 7, 11, 13 through 17, 22, and 23)
	803887	1	1/2 HP 240v 1 ϕ 50 Hz T.E.F.C. Motor Mount Assembly Complete <i>without</i> Plug Motor (includes illus. nos. 1 through 7, 11, 13, through 17, 22, and 23) For models mfd. prior to August 28, 1992
8	150501	4	5/16-18 x 3/4" Hex Head Machine Bolt
9	153002	4	5/16" Lock Washer
10	153001	4	5/16" Flat Washer
11	154000	4	5/16-18 Tinnerman Nut
12	100065**	1	1/2 HP 100-230v 1 ϕ 50/60 Hz T.E.F.C. Motor <i>with</i> Plug
	100066	1	1/2 HP 240v 1 ϕ 50 Hz T.E.F.C. Motor <i>with</i> Plug (for models mfd. as of August 28, 1992)
13	150501	4	5/16-18 x 3/4" Hex Head Machine Bolt
14	153002	4	5/16" Lock Washer
15	153001	4	5/16" Flat Washer
16	153001	*	5/16" Flat Washer
17	101131	1	1/2" x 2-1/4" Motor Pulley (for use on 1 ϕ - 60 Hz models Only)
	101133	1	5/8" x 2-1/4" Motor Pulley (for use on 3 ϕ - 60 Hz models Only)
	101130	1	5/8" x 2-1/2" Motor Pulley (for use on 1 ϕ /3 ϕ - 60 Hz models Only)
18	100113	1	4L-400 V-Belt (motor to idler) For use on 60 Hz models ONLY 4L-410 V-Belt (motor to idler) For use on 50 Hz models ONLY
19	122701	8	Socket Terminal ONLY
20	137030	1	8-Pin Housing ONLY
	122801	1	Pin/Socket Extraction Tool
21	837005	1	120 Volt 1 ϕ Motor Harness with Plug
	837006	1	230 Volt 1 ϕ Motor Harness with Plug
22	100007	1	1/2 HP 208/230/380/460v 3 ϕ 50/60 Hz T.E.F.C. Motor
	100035	1	1/2 HP 240v 1 ϕ 50 Hz T.E.F.C. Motor (for models mfd. prior to August 28, 1992)
23	120200	1	3/8" x 90° Connector
24	100701	1	3/16" x 3/16" x 1" Key (for use on 3 ϕ models Only)

* As required.

** Specify voltage when ordering.

UPPER SAIL SWITCH ASSEMBLY

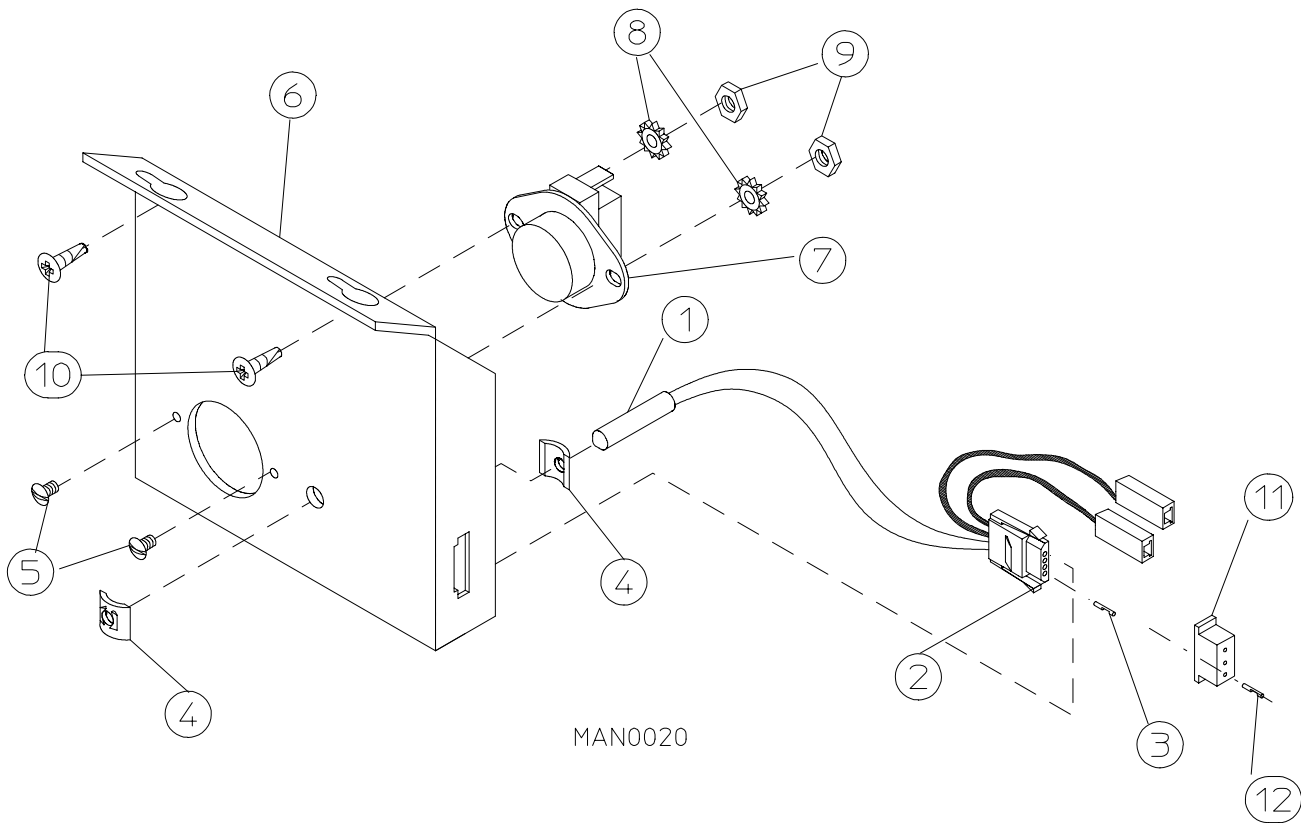

NOTE: DUPLICATE ALL COMPONENTS FOR LOWER SENSOR BRACKET ASSEMBLY.

<u>Illus. No.</u>	<u>Part No.</u>	<u>Qty.</u>	<u>Description</u>
1	880251	1	1/4" Temperature Sensor Probe Assembly (includes illus. nos. 1 through 4)
2	122605	1	4-Pin Socket Connector ONLY
3	122701	4	Socket Terminal Only
4	154007	2	1/4" Tinnerman Push-on Fastener
5	150000	2	#6-32 x 1/4" Round Head Machine Screw
6	801428	1	Sensor Bracket Assembly Complete (includes illus. nos. 1 through 9)
	305107	1	Temperature Sensor Bracket ONLY
7	130103	1	225° Large Automatic Thermostat
8	153010	2	#6 Star Washer
9	152000	22	#6-32Hex Nut
10	150301	2	#8-18 x 7/16" Phillips Pan Head TEK Screw
11	122604	1	4-Pin Connector ONLY
12	122700	4	Pin Terminal ONLY
--	122801	1	Pin/Socket Extraction Tool

UPPER SAIL SWITCH ASSEMBLY

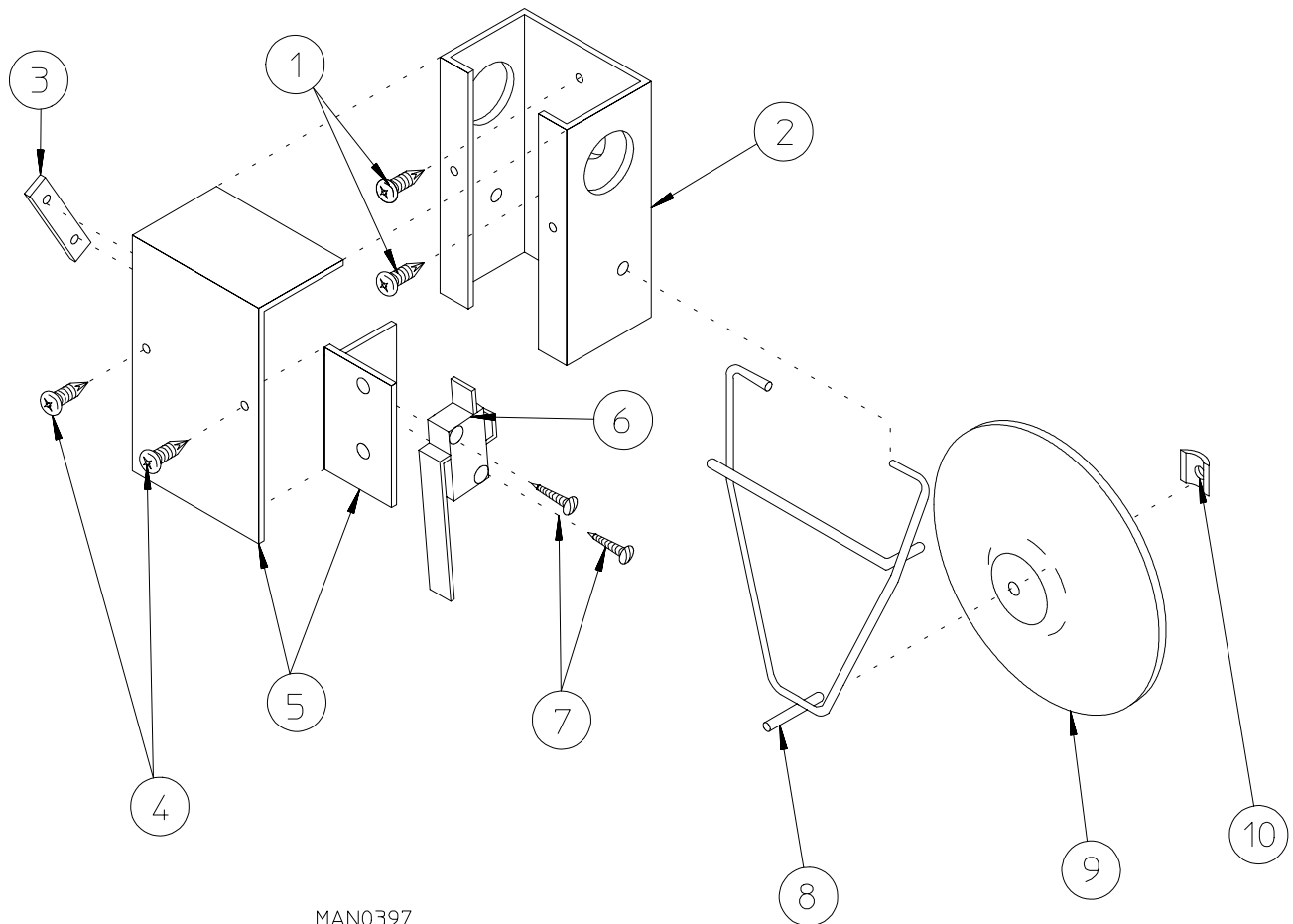

MAN0397

NOTE: DUPLICATE ALL COMPONENTS FOR LOWER SAIL SWITCH ASSEMBLY.

<u>Illus. No.</u>	<u>Part No.</u>	<u>Qty.</u>	<u>Description</u>
1	150301	2	#8-18 x 7/16" Phillips Pan Head TEK Screw
2	802800	1	Sail Switch Box with Cover and Bracket ONLY (includes illus. nos. 2, 4, and 5)
3	154004	1	Twin Speed Nut
4	150309	2	10-16 x 1/2" Phillips Round Head Crimptite Screw
5	802709	1	Sail Switch Box Cover and Bracket ONLY
6	122200	1	Sail Switch ONLY
7	150303	2	#4 x 3/4" Pan Head "A" Machine Screw
8	105500	1	Sail Switch Actuator Rod
9	319202	1	Sail Switch Damper (embossed)
10	154002	1	1/8" Push-on Fastener

UPPER GAS VALVE/BURNER ASSEMBLY

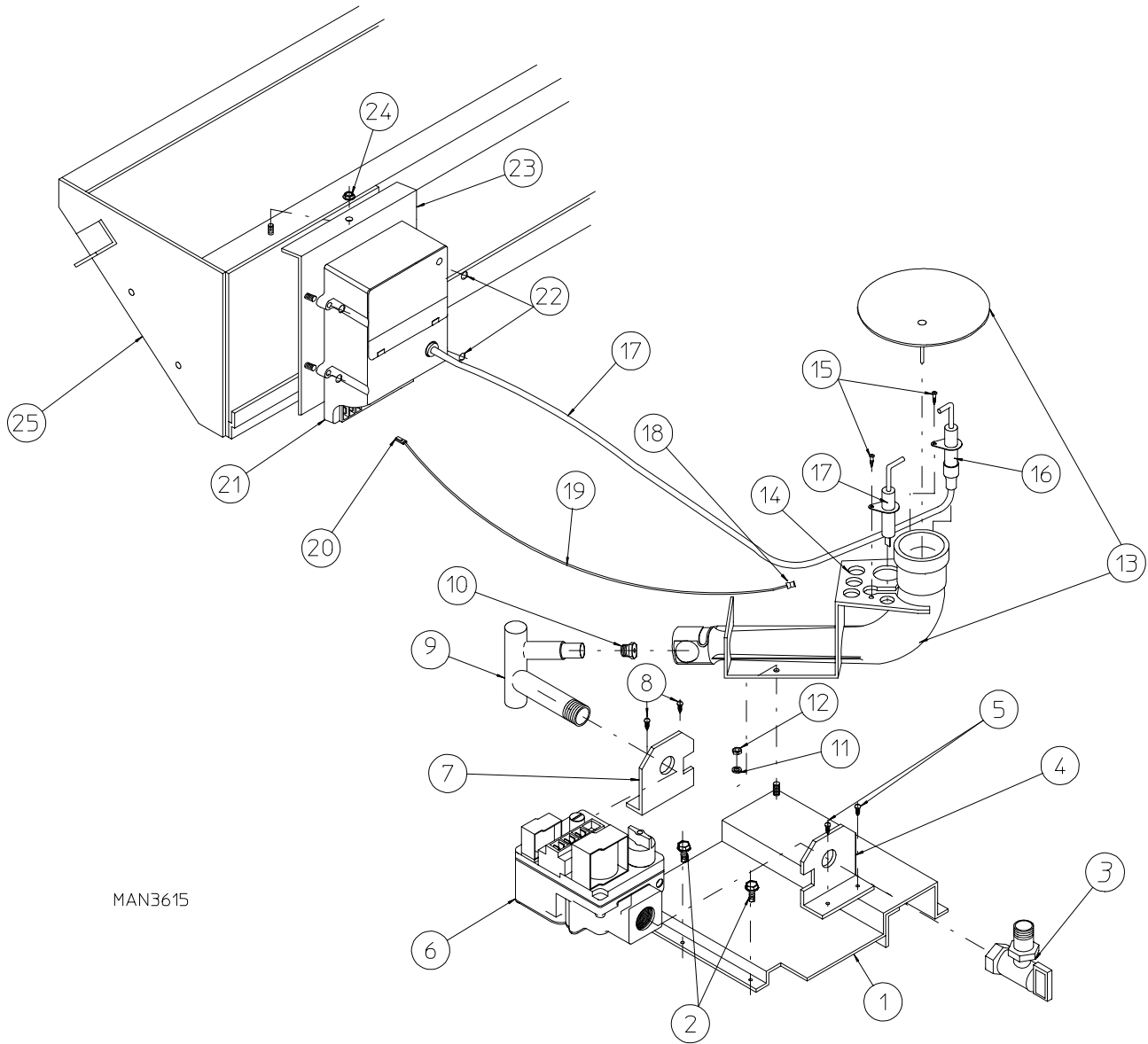

MAN3615

NOTE: DUPLICATE ALL COMPONENTS FOR LOWER GAS VALVE/BURNER ASSEMBLY.

<u>Illus. No.</u>	<u>Part No.</u>	<u>Qty.</u>	<u>Description</u>
1	850804	1	DSI Gas Valve/Burner Tube Mounting Plate ONLY
	809313*	1	DSI (natural gas) Valve/Burner Assembly Complete less Orifice (includes illus. nos. 1, 3, 5 through 10 and 12 through 21)
	809314*	1	DSI (liquid propane) Gas Valve/Burner Assembly Complete less Orifice (includes illus. nos. 1, 3, 5 through 10 and 12 through 21)
2	150300	2	#10 x 1/2" Hex Washer TEK Screw
3	881367	1	Angle Union Shut Off with 1/2" Tail Piece
4	318650	1	Notched Pipe Bracket
5	150301	2	#8-18 x 7/16" Phillips Pan Head TEK Screw
6	128927	1	1/2" 24 VAC Redundant (natural gas) Valve
	140411	1	1/2" 24 VAC Gas Valve L.P. (liquid propane) Conversion Kit
7	318650	1	Notched Pipe Bracket
8	150301	2	#8-18 x 7/16" Phillips Pan Head TEK Screw
9	141235	1	1/2" Single Port Manifold
10*	140828	1	#20 Burner Orifice (natural gas) ONLY
	140811	1	#41 Burner Orifice (liquid propane gas) ONLY
11	153000	1	#8 Steel Burr
12	152001	1	#8-32 Hex Nut
13	141131	1	DSI (Direct Spark Ignition) Up-Shot Burner Tube with Flame Spreader
	141130	1	DSI (Direct Spark Ignition) Up-Shot Burner Tube ONLY
	141109	1	Flame Spreader ONLY
14	318009	1	Burner Tube Bracket (PSE)
15	150315	2	#6 x 3/8" Phillips Pan Head Machine Screw
16	128917	1	Spark Electrode with High Voltage (HV) Wire
	305412	1	DSI Ignitor Gap Feeler Gauge ... Not Illustrated
17	128918	1	Flame Sensor Probe
18	121006	1	#10 Insulated Terminal
19	132607	2	#18 Gauge Red Silicone Wire (sold in feet)
20	121028	1	1/4" x .032 Insulated Terminal
21	880815	1	ADC DSI Module ONLY (50/60 Hz)
22	151000	4	#6-32 Pal Nut
23	801013	1	DSI Module Mounting Bracket ONLY
24	152014	1	1/4-20 Free Spin Wash Nut
25	-----	-	Idler Bearing Mount
--	874059**	1	(refer to Idler Bearing Assembly on page 14 and page 15) ADG-235 Burner L.P. Conversion Kit with Orifice

* Burner Orifice is *not included* and **must be** ordered separately.

** Consult factory for elevations over 2,000 feet.

UPPER GAS BURNER CHAMBER ASSEMBLY

NOTE: DUPLICATE ALL COMPONENTS FOR LOWER GAS BURNER CHAMBER ASSEMBLY.

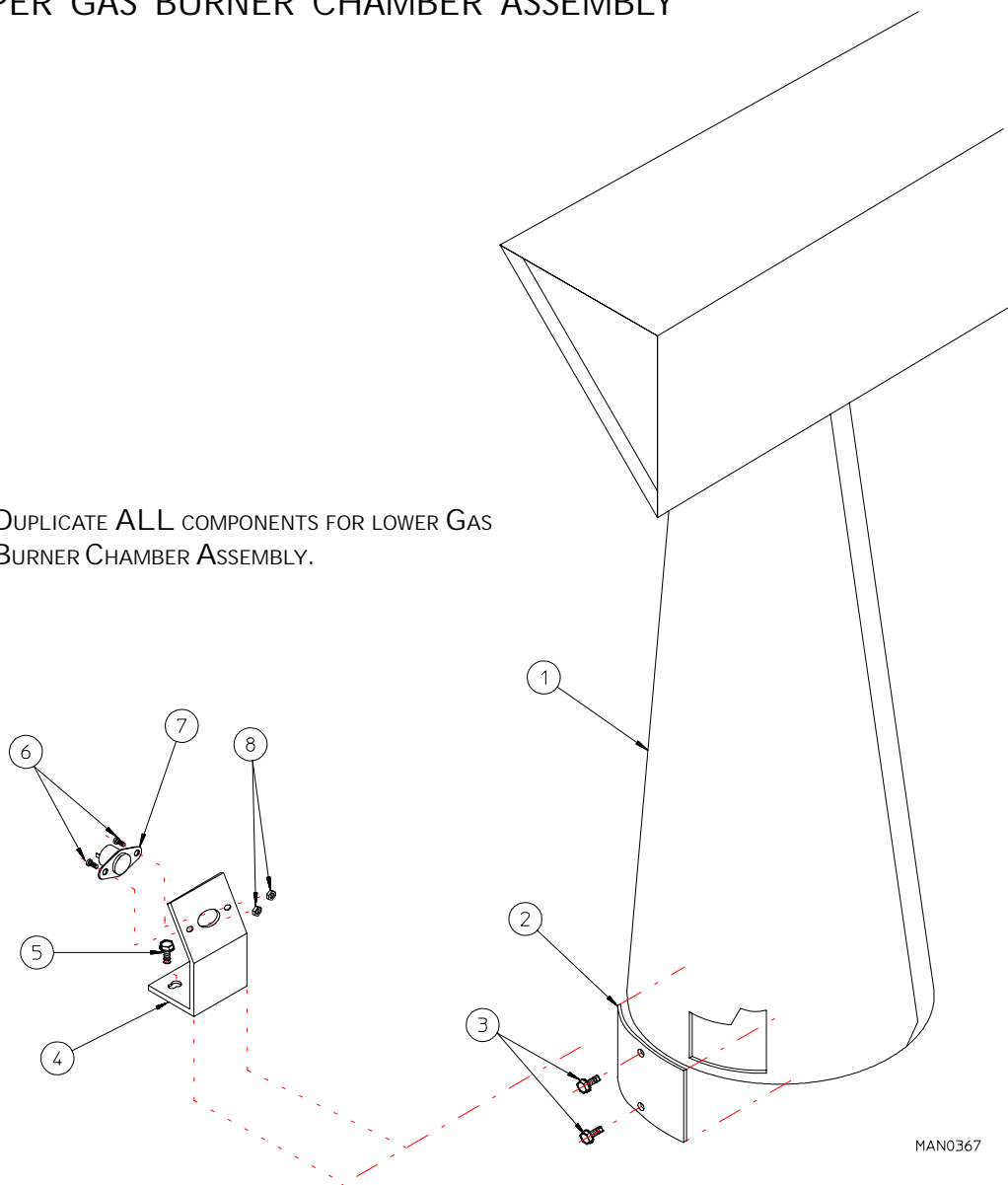

MAN0367

Illus. No.	Part No.	Qty.	Description
1	804025	1	Gas Burner/Electric Oven Chamber Assembly (includes illus. nos. 1, 2, and 3)
2	318006	1	Flame Viewing Plate
3	150300	2	#10 x 1/2" Hex Washer TEK Screw
4	802502	1	Hi Limit Bracket Assembly (includes illus. nos. 4 through 8)
	319710	1	Hi Limit Bracket ONLY
5	150301	2	#8-18 x 7/16" Phillips Pan Head TEK Screw
6	150001	2	#6-32 x 1/2" Right Hand Machine Screw
7	130103	1	225° Large Automatic Thermostat
8	151000	2	#6-32 Pal Nut

MAN0018

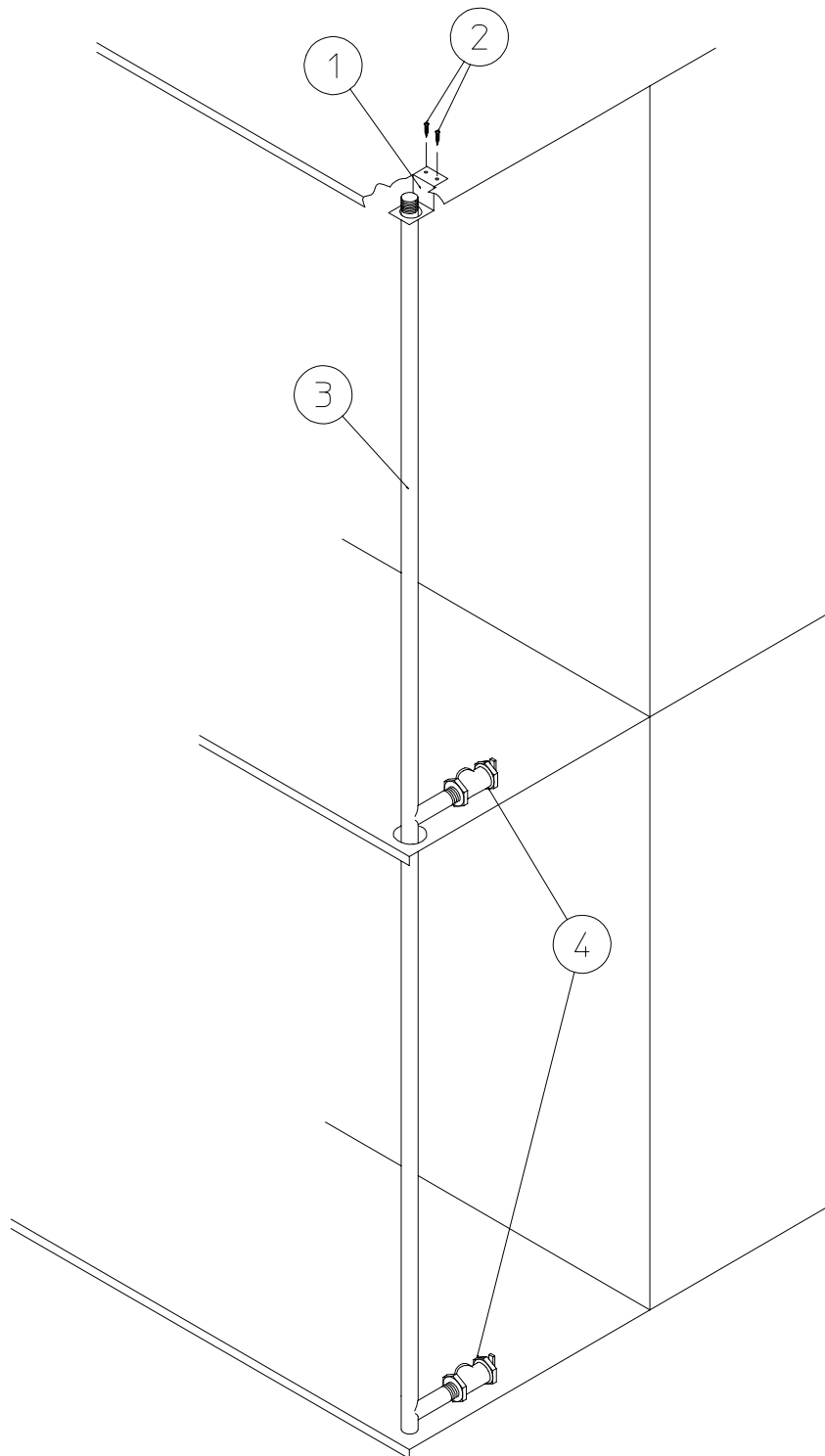

<u>Illus. No.</u>	<u>Part No.</u>	<u>Qty.</u>	<u>Description</u>
1	318702	1	Top Pipe Support Bracket ONLY
2	150300	2	#10 x 1/2" Hex Washer TEK Screw
3	141236	1	Gas Piping Manifold
4	881367	2	Angle Union Shut Off with 1/2" Tail Piece

UPPER ELECTRICAL RELAY PANEL ASSEMBLY

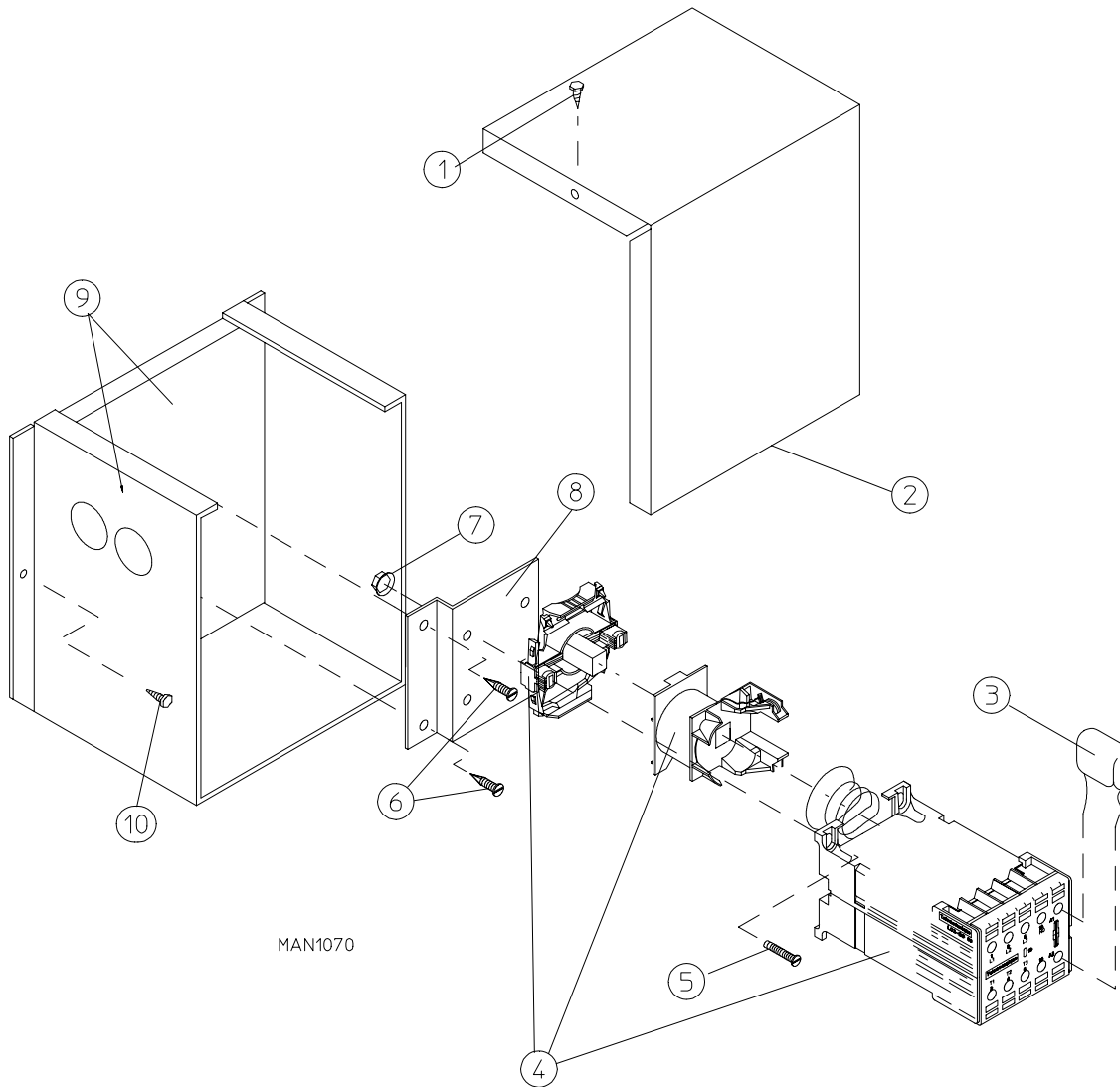

NOTE: DUPLICATE ALL COMPONENTS FOR LOWER ELECTRICAL RELAY PANEL ASSEMBLY.

<u>Illus. No.</u>	<u>Part No.</u>	<u>Qty.</u>	<u>Description</u>
1	150300	2	#10 x 1/2" Hex Washer TEK Screw
2	321002	1	Electrical Relay Panel Cover ONLY
3	137015	1	Arc Suppressor (capacitor)
4	132430	1	Impellor Contactor Coil - 24 VAC (208/230/240v - 50/60 Hz)
	132432	1	Impellor Contactor Replacement Coil - 24 VAC (208/230/240v - 50/60 Hz)
5	150108	4	#8-32 x 1/2" Phillips Pan Head Machine Screw
6	150300	2	#10 x 1/2" Hex Washer TEK Screw
7	151001	4	#8-32 Pal Nut
8	311920	1	3-Phase (3 ϕ) Contactor Mounting Bracket ONLY
9	850909	1	Electrical Relay Panel Assembly (includes illus. nos. 1, 2, and 9)

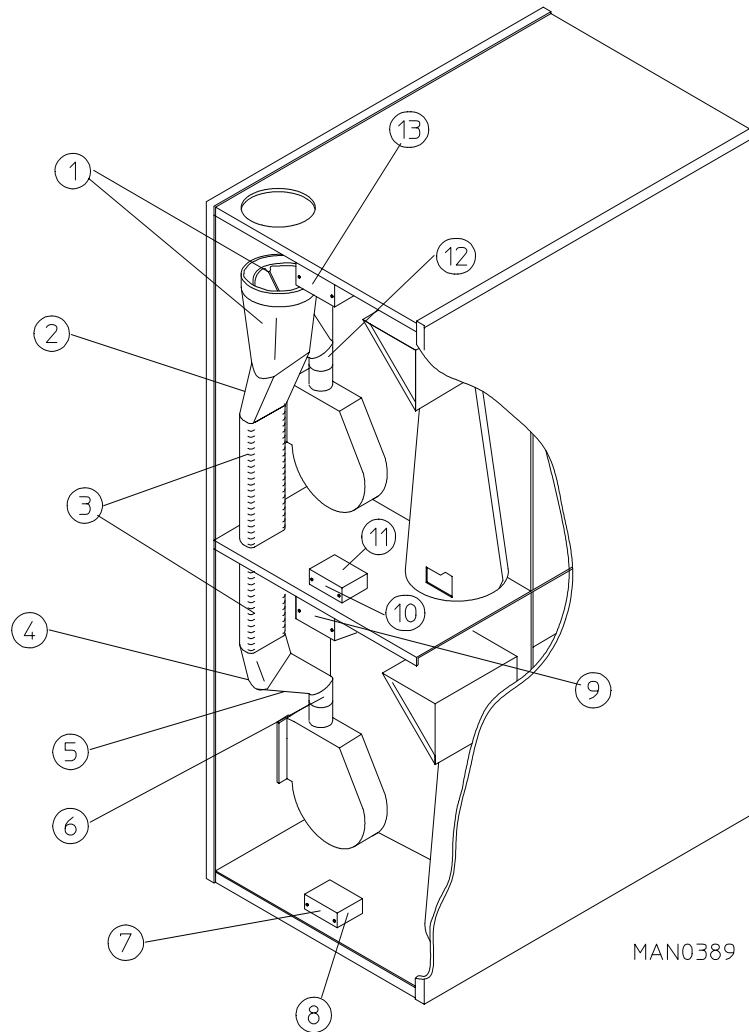

<u>Illus. No.</u>	<u>Part No.</u>	<u>Qty.</u>	<u>Description</u>
1	880505	1	Wye Branch Damper Assembly
2	143527	1	6" Round x 7" Oval Straight Boot
3	143539	1	15-1/2" x 7" Oval Duct
4	143537	1	7" Oval x 45° Elbow
5	143538	1	6" Round x 7" Oval Straight Boot
6	143536	1	6" Round x 45° Elbow
7	121104	1	Junction Box Only
8	121105	1	Junction Box Cover ONLY
	150301	2	#8-18 x 7/16" Phillips Pan Head TEK Screw ... Not Illustrated
9	315025	1	Rear Wiring Box Cover ONLY
	150300	2	#10 x 1/2" Hex Washer TEK Screw ... Not Illustrated
10	121104	1	Junction Box
11	121105	1	Junction Box Cover ONLY
	150301	2	#8-18 x 7/16" Phillips Head TEK Screw ... Not Illustrated
12	143536	1	6" Round x 45° Elbow
13	315025	1	Rear Wiring Box Cover ONLY
	150300	2	#10 x 1/2" Hex Washer TEK Screw ... Not Illustrated
--	117505	*	Aluminum Duct Tape (sold by the foot)

* As required.

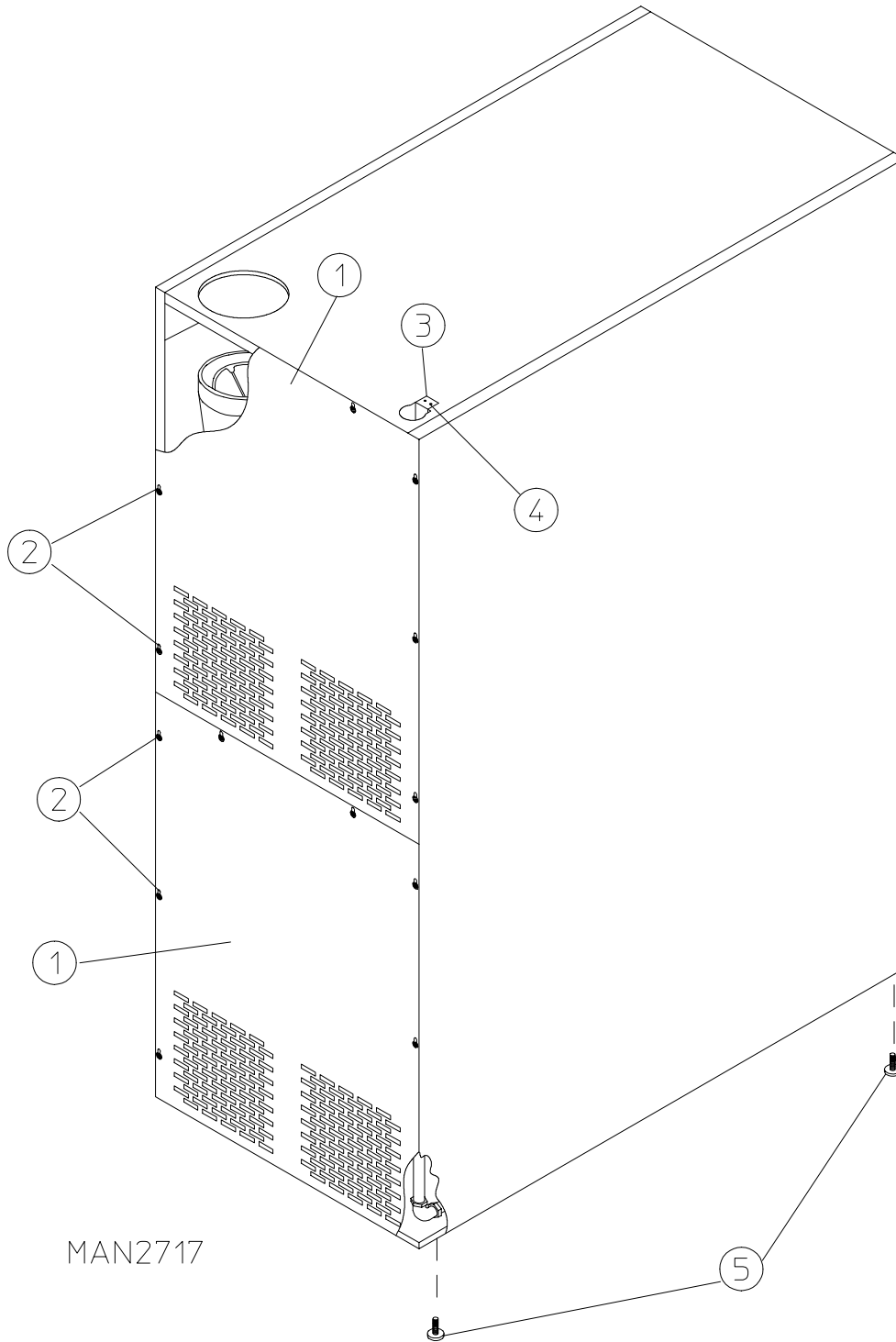

<u>Illus. No.</u>	<u>Part No.</u>	<u>Qty.</u>	<u>Description</u>
1	311014	2	Upper/Lower Back Guard Assembly
2	150301	16	#8-18 x 7/16" Phillips Pan Head TEK Screw
3	318702	1	Top Pipe Support Bracket ONLY
4	150300	2	#10 x 1/2" Hex Washer TEK Screw
5	103500	4	Adjustable Leveling Leg

NOTE: Coin acceptors listed include Optical Switch (ADC Part No. 137056).

SINGLE COIN*

<u>ADC Part No.</u>	<u>Nation</u>	<u>Description</u>
125100	U.S. and Canada	25¢ Optic Coin Acceptor
125127	Canada	\$1 Canadian Optic Coin Acceptor
125101	United Kingdom	10 New Pence Optic Coin Acceptor
125114	United Kingdom	20 New Pence Optic Coin Acceptor
125115	United Kingdom	1 Pound Optic Coin Acceptor
125106	France	1 French Franc Optic Coin Acceptor
125120	France	2 French Franc Optic Coin Acceptor
125124	France	5 French Franc Optic Coin Acceptor
125109	Denmark	1 Danish Krone Optic Coin Acceptor
125125	Netherlands	25¢ Guilder Optic Coin Acceptor
125108	Australia	10¢ Australian Optic Coin Acceptor
125107	Australia	20¢ Australian Optic Coin Acceptor
125130	Australia	\$1 Australian Optic Coin Acceptor
125123	New Zealand	50¢ New Zealand Optic Coin Acceptor
125104	Japan	100 Yen Optic Coin Acceptor
125103	---	.882 Token Optic Coin Acceptor
125121	---	.800 Token Optic Coin Acceptor
125129	---	Muller Token Optic Coin Acceptor
125132	Singapore	50¢ Singapore Optic Coin Acceptor
125133	Hong Kong	\$1 Hong Kong Optic Coin Acceptor

DUAL COIN*

125116	U.S. and Canada	10¢ / 25¢ Dual Optic Coin Acceptor
125128	Canada	25¢ / \$1 Dual Optic Coin Acceptor
125112	United Kingdom	10 / 20 Pence Dual Optic Coin Acceptor
125110	United Kingdom	10 / 50 Pence Dual Optic Coin Acceptor
125111	United Kingdom	20 / 50 Pence Dual Optic Coin Acceptor
125113	United Kingdom	1£ / 20 Pence Dual Optic Coin Acceptor
125122	France	2 / 5 Franc Dual Optic Coin Acceptor
125117	Denmark	1 / 5 Danish Krone Dual Optic Coin Acceptor
125131	Denmark	5 / 10 Danish Krone Dual Optic Coin Acceptor
125126	Netherlands	25¢ / 1 Guilder Dual Optic Coin Acceptor
125118	Singapore	20¢ / 50¢ Singapore Dual Optic Coin Acceptor
125105	Japan	50 / 100 Yen Dual Optic Coin Acceptor

* Consult factory for coin acceptors not listed

<u>Part No.</u>	<u>Description</u>
112039	“Black/White/Green Ground” Label
112280	“Clean Lint Screen” Label
114001	“CAUTION -Exhaust/Lint Screen” Label
114006	“WARNING - Fire Hazard” Label
120100	3/8” Straight BX Connector
120300	3/8” x 45° BX Connector
120400	3/8” Red Jacket (BX Insulator)
120500	3/8” Jiffy Clip (BX Retainer Clip)
120600	3/8” Greenfield (BX)
120800	1/4” In-Line Connector
120802	Red Butt Connector
120902	#74B Wire Nut
120903	Crimp-On Wire Nut
121014	1/4” Insulated Female Terminal
121499	4” Harness Tie
121500	7” Harness Tie
121503	Harness Tie Mounting Clip
122804	Manometer (water column test gauge)
170194	Tumbler Lint Cleaning Brush
404500	Almond Brush-In-Cap Bottle Touch-Up Paint
404502	White Brush-In-Cap Bottle Touch-Up Paint
404506	Beige Brush-In-Cap Bottle Touch-Up Paint
404507	Cornflower Blue Brush-In-Cap Bottle Touch-Up Paint
880200	Electric Terminal Assortment Kit

ADC 450133 1- 05/17/93-100 2* 10/23/95-100 3* 06/06/97-100
4* 02/24/98-100

Telephone: (508) 678-9010



Fax: (508) 678-9447